

***SED1330F/1335F/1336F***  
***LCD Controller ICs***  
***Technical Manual***

***S-MOS Systems, Inc.***  
***September, 1995***  
***Version 0.4***

**THIS PAGE INTENTIONALLY BLANK**

**CONTENTS**

- 1.0 Overview ..... 9**
  - 1.1 Description ..... 11
  - 1.2 Features ..... 11
  - 1.3 Block Diagram ..... 12
  - 1.4 Pinouts ..... 14
    - 1.4.1 SED1330FBA, 1335FBB and SED1336F0A Pinouts ..... 14
    - 1.4.2 SED1330FBA and SED1335F0A Pinouts ..... 14
  - 1.5 Package Dimensions ..... 15
  
- 2.0 Pin Description ..... 17**
  - 2.1 SED1330FBA/BB Pin Summary ..... 18
  - 2.2 SED1330F/1335F0A/0B Pin Summary ..... 19
  - 2.3 SED1336F0A Pin Summary ..... 20
  - 2.4 Pin Functions ..... 21
    - 2.4.1 Power Supply ..... 21
    - 2.4.2 Oscillator ..... 21
    - 2.4.3 Microprocessor Interface ..... 21
    - 2.4.4 Display Memory Control ..... 23
    - 2.4.5 LCD Drive Signals ..... 23
  
- 3.0 Command Description ..... 25**
  - 3.1 The Command Set ..... 27
  - 3.2 System Control Commands ..... 28
    - 3.2.1 SYSTEM SET ..... 28
      - 3.2.1.1 C ..... 29
      - 3.2.1.2 M0 ..... 29
      - 3.2.1.3 M1 ..... 29
      - 3.2.1.4 M2 ..... 29
      - 3.2.1.5 W/S ..... 29
      - 3.2.1.6 IV ..... 32
      - 3.2.1.7 T/L ..... 32
      - 3.2.1.8 DR ..... 32
      - 3.2.1.9 FX ..... 32
      - 3.2.1.10 WF ..... 33
      - 3.2.1.11 FY ..... 33
      - 3.2.1.12 C/R ..... 34
      - 3.2.1.13 TC/R ..... 34
      - 3.2.1.14 L/F ..... 35
      - 3.2.1.15 AP ..... 35
    - 3.2.2 SLEEP IN ..... 36

3.3 Display Control Commands ..... 36

    3.3.1 DISP ON/OFF ..... 36

        3.3.1.1 D ..... 37

        3.3.1.2 FC ..... 37

        3.3.1.3 FP ..... 37

    3.3.2 SCROLL ..... 37

        3.3.2.1 C ..... 37

        3.3.2.2 SL1, SL2 ..... 38

    3.3.3 CSRFORM ..... 42

        3.3.3.1 CRX ..... 42

        3.3.3.2 CRY ..... 42

        3.3.3.3 CM ..... 43

    3.3.4 CSRDIR ..... 43

    3.3.5 OVLAY ..... 43

        3.3.5.1 MX0, MX1 ..... 43

        3.3.5.2 DM1, DM2 ..... 45

        3.3.5.3 OV ..... 45

    3.3.6 CGRAM ADR ..... 45

    3.3.7 HDOT SCR ..... 45

        3.3.7.1 D0 to D2 ..... 45

3.4 Drawing Control Commands ..... 46

    3.4.1 CSRW ..... 46

    3.4.2 CSRR ..... 46

3.5 Memory Control Commands ..... 47

    3.5.1 MWRITE ..... 47

    3.5.2 MREAD ..... 47

**4.0 Specifications ..... 49**

4.1 Absolute Maximum Ratings ..... 51

    4.1.1 SED1330 ..... 51

    4.1.2 SED1335/SED1336 ..... 51

4.2 SED 1330 Electrical Characteristics ..... 52

4.3 SED1335/1336 Electrical Characteristics ..... 53

4.4 SED1330 Timing Diagrams ..... 54

    4.4.1 System bus READ/WRITE timing I (8080) ..... 54

        4.4.1.1 SED1330F ..... 54

    4.4.2 System bus READ/WRITE timing II (6800) ..... 55

        4.4.2.1 SED1330F ..... 55

    4.4.3 Display memory READ timing ..... 56

        4.4.3.1 SED1330F ..... 56

    4.4.4 Display memory WRITE timing ..... 57

        4.4.4.1 SED1330F ..... 57

    4.4.5 LCD control timing ..... 58

        4.4.5.1 SED1330F ..... 59

- 4.4.6 Oscillator timing ..... 60
  - 4.4.6.1 SED1330F ..... 60
- 4.4.7 Measurement circuit ..... 61
- 4.5 SED1335/SED1336 AC Timing Diagrams ..... 62
  - 4.5.1 8080 family Interface Timing ..... 62
    - 4.5.1.1 SED1335F ..... 62
    - 4.5.1.2 SED1336F ..... 63
  - 4.5.2 6800 family Interface Timing ..... 64
    - 4.5.2.1 SED1335F ..... 65
    - 4.5.2.2 SED1336F ..... 65
  - 4.5.3 Display Memory Read Timing ..... 66
    - 4.5.3.1 SED1335F ..... 66
    - 4.5.3.2 SED1336F ..... 67
  - 4.5.4 Display Memory Write Timing ..... 68
    - 4.5.4.1 SED1335F ..... 69
    - 4.5.4.2 SED1336F ..... 70
  - 4.5.5 SLEEP IN Command Timing ..... 71
    - 4.5.5.1 SED1335F ..... 71
    - 4.5.5.2 SED1336F ..... 71
  - 4.5.6 External Oscillator Signal Timing ..... 72
    - 4.5.6.1 SED1335F ..... 72
    - 4.5.6.2 SED1336F ..... 72
  - 4.5.7 E-1330 LCD Controller IC ..... 73
    - 4.5.7.1 SED1335F ..... 75
    - 4.5.7.2 SED1336F ..... 75

**5.0 Display Control Functions ..... 77**

- 5.1 Character Configuration ..... 79
- 5.2 Screen Configuration ..... 81
  - 5.2.1 Screen Configuration ..... 81
  - 5.2.2 Display Address Scanning ..... 81
  - 5.2.3 Display Scan Timing ..... 84
- 5.3 Cursor Control ..... 85
  - 5.3.1 Cursor Register Function ..... 85
  - 5.3.2 Cursor Movement ..... 85
  - 5.3.3 Cursor Display Layers ..... 85
- 5.4 Memory to Display Relationship ..... 87
- 5.5 Scrolling ..... 90
  - 5.5.1 On-page Scrolling ..... 90
  - 5.5.2 Inter-page Scrolling ..... 91
  - 5.5.3 Horizontal Scrolling ..... 92
  - 5.5.4 Bidirectional Scrolling ..... 93
  - 5.5.5 Scroll Units ..... 93

**6.0 Character Generator ..... 95**

- 6.1 CG Characteristics ..... 97
  - 6.1.1 Internal Character Generator ..... 97
  - 6.1.2 External Character Generator ROM ..... 97
  - 6.1.3 Character Generator RAM ..... 97
- 6.2 CG Memory Allocation ..... 98
- 6.3 Setting the Character Generator Address ..... 99
  - 6.3.1 M1 = 1 ..... 100
  - 6.3.2 CG RAM Addressing Example ..... 100
- 6.4 Character Codes ..... 101

**7.0 TV Mode (SED1336F only) ..... 103**

- 7.1 Sync Generator Circuit Timing ..... 105

**8.0 Description of Circuit Blocks ..... 109**

- 8.1 Microprocessor Interface ..... 111
  - 8.1.1 System Bus Interface ..... 111
    - 8.1.1.1 8080 series ..... 111
    - 8.1.1.2 6800 series ..... 111
  - 8.1.2 Microprocessor Synchronization ..... 111
    - 8.1.2.1 Display Status Indication Output For SED1336F only ..... 111
    - 8.1.2.2 Internal Register Access ..... 111
    - 8.1.2.3 Display Memory Access ..... 111
  - 8.1.3 Interface Examples ..... 113
    - 8.1.3.1 Z80® to SED1330F/1335F/1336F Interface ..... 113
    - 8.1.3.2 6802 to SED1330F/1335F/1336F Interface ..... 114
- 8.2 Display Memory Interface ..... 115
  - 8.2.1 Static RAM ..... 115
  - 8.2.2 Supply Current during Display Memory Access ..... 115
- 8.3 Oscillator Circuit ..... 116
- 8.4 Status Flag ..... 116
- 8.5 Reset ..... 117

**9.0 Application Notes ..... 119**

- 9.1 Initialization Parameters ..... 121
  - 9.1.1 SYSTEM SET Instruction and Parameters ..... 121
  - 9.1.2 Initialization Example ..... 122
  - 9.1.3 Display Mode Setting Example 1: Combining Text and Graphics ..... 128
  - 9.1.4 Display Mode Setting Example 2: Combining Graphics and Graphics ..... 129
  - 9.1.5 Display Mode Setting Example 3: Combining Three Graphics Layers ..... 130
- 9.2 System Overview ..... 132

9.3 System Interconnection .....	133
9.3.1 SED1330F/1335F .....	133
9.3.2 SED1336F .....	134
9.4 Smooth Horizontal Scrolling .....	135
9.5 Layered Display Attributes .....	137
9.5.1 Inverse Display .....	137
9.5.2 Half-tone Display .....	137
9.5.2.1 Menu Pad Display .....	137
9.5.2.2 Graph Display .....	138
9.5.3 Flashing Areas .....	138
9.5.3.1 Small Area .....	138
9.5.3.2 Large Area .....	138
9.6 16 × 16-dot Graphic Display .....	139
9.6.1 Command Usage .....	139
9.6.2 Kanji Character Display .....	139
<b>10.0 Internal Character Generator Font .....</b>	<b>141</b>
<b>11.0 Glossary of Terms .....</b>	<b>145</b>

**THIS PAGE INTENTIONALLY BLANK**



# *1.0*

## *Overview*

**THIS PAGE INTENTIONALLY BLANK**

## 1.0 Overview

### 1.1 Description

The SED1330/1335F/1336F is a family of versatile LCD controller ICs that can display text and graphics on a medium size LCD panel. The software is compatible among all three chips. S-MOS recommends new designs use the SED1335 since the SED1330 will gradually be replaced by the SED1335.

The SED1336F incorporates a TV sync generator circuit that is compatible with both NTSC and PAL systems. The  $256 \times 200$  pixel TV display comprises three superimposed layers, and is identical to the simultaneous LCD panel display. When driving an LCD only, up to 3 overlapping layers can be displayed on LCD panels up to  $640 \times 256$  pixels in size. The SED1330/1335F does not incorporate a TV controller.

The SED1330/1335F/1336F can display layered text and graphics, scroll the display in any direction and partition the display into multiple screens.

The SED1330/1335F/1336F stores text, character codes and bit-mapped graphics data in external frame buffer memory. Display controller functions include transferring data from the controlling microprocessor to the buffer memory, reading memory data, converting data to display pixels and generating timing signals for the buffer memory, TV monitor and LCD panel.

The SED1330/1335F/1336F has an internal character generator with 160,  $5 \times 7$  pixel characters in internal mask ROM. The character generators support up to 64,  $8 \times 16$  pixel characters in external character generator RAM and up to 256,  $8 \times 16$  pixel characters in external character generator ROM.

### 1.2 Features

- Text, graphics and combined text/graphics display modes
- Three overlapping screens in graphics mode
- $640 \times 256$  pixel LCD panel display resolution
- Programmable cursor control
- Smooth horizontal and vertical scrolling of all or part of the display
- 1/2-duty to 1/256-duty LCD drive
- Up to 64 Kbytes of external static RAM frame buffer memory
- Internal character generator
- 160,  $5 \times 7$  pixel characters in internal mask-programmed character generator ROM
- Up to 64,  $8 \times 16$  pixel characters in external character generator RAM
- Up to 256,  $8 \times 16$  pixel characters in external character generator ROM
- 6800 and 8080 family microprocessor interfaces
- NTSC and PAL systems compatible (SED1336F only)
- $256 \times 200$  pixel TV monitor display resolution (SED1336F only)
- Low power consumption—3.5 mA operating current ( $V_{DD} = 3.5V$ ), 0.05  $\mu A$  standby current
- 4.5 to 5.5V (SED1330F)
- 2.7 to 5.5V (SED1330F/1335F)
- 3.0 to 5.5V (SED1336F)
- Available in 60-pin QFPs

1.3 Block Diagram

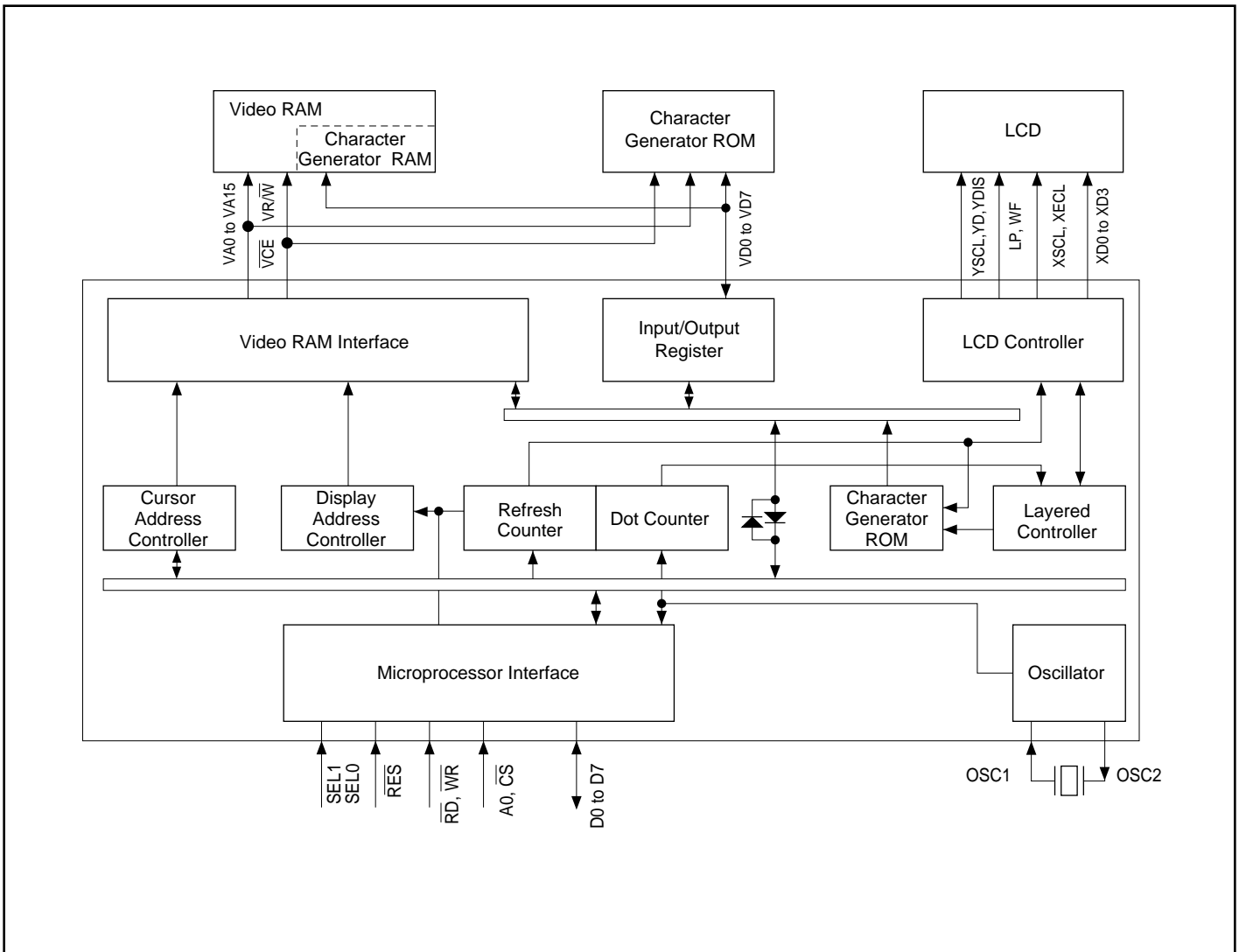

Figure 1. SED1330F block diagram

1.3 Block Diagram

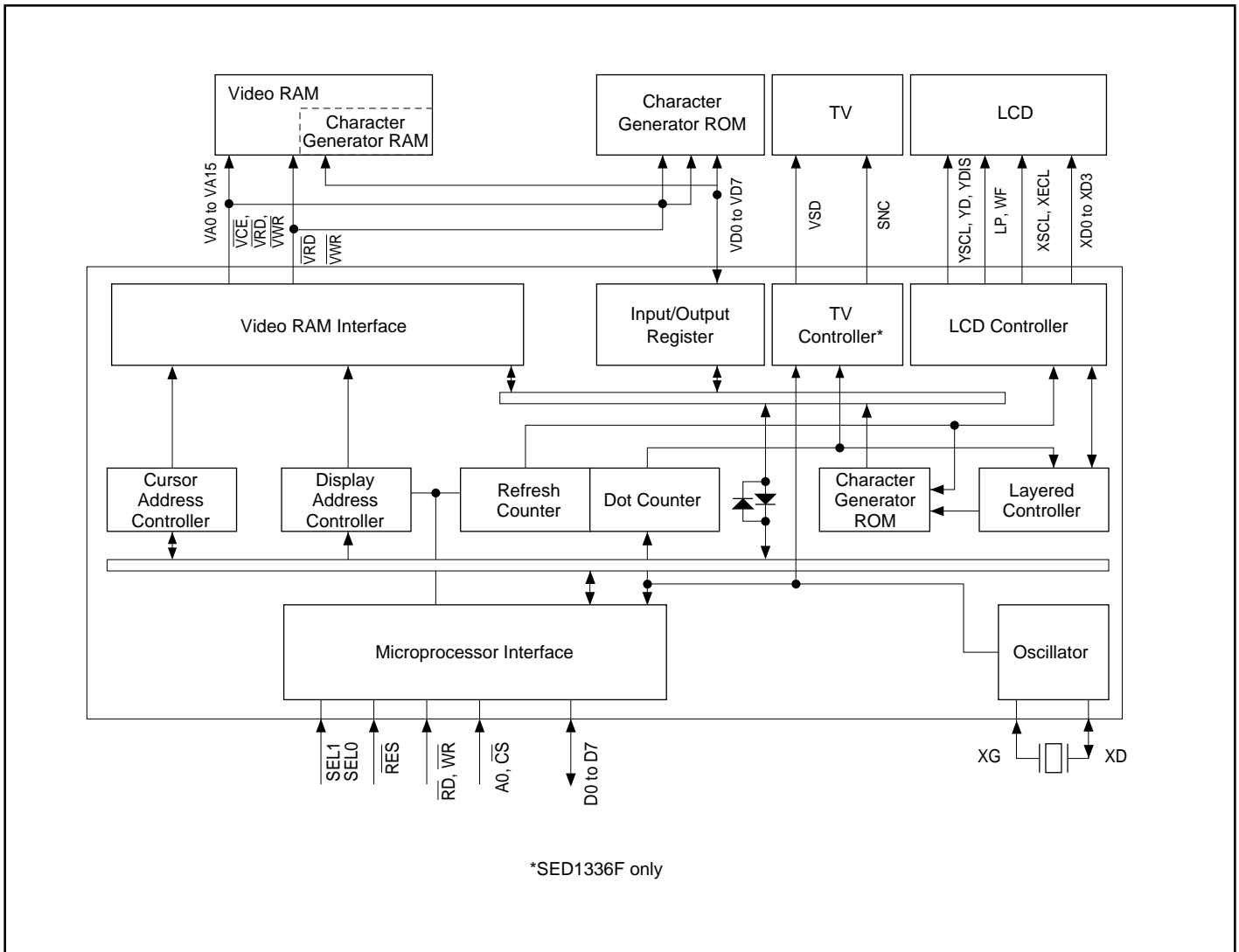

Figure 2. SED1335F/1336F block diagram

1.4 Pinouts

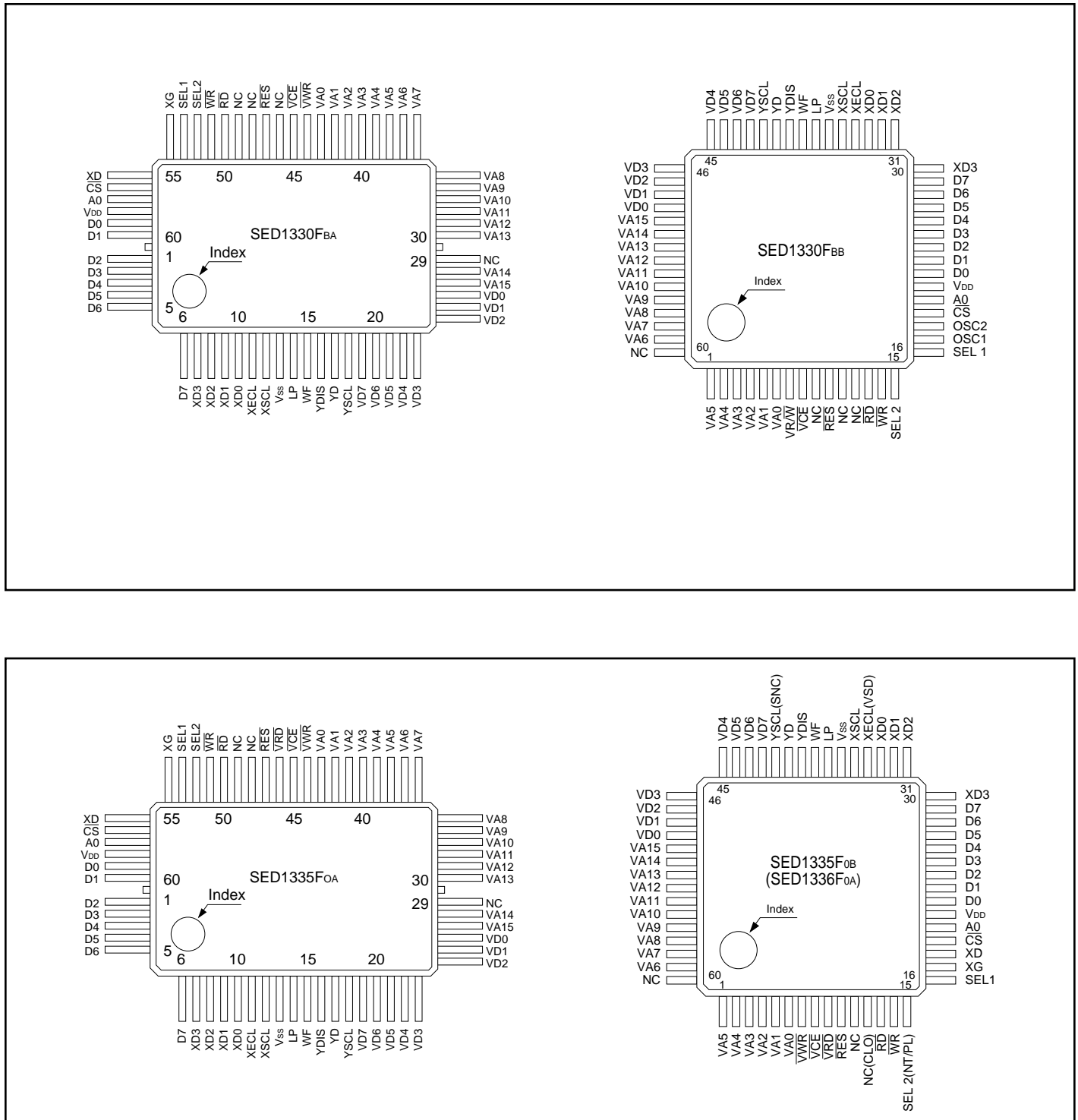

Figure 3. SED1330F and SED1335F pinouts

1.5 Package Dimensions

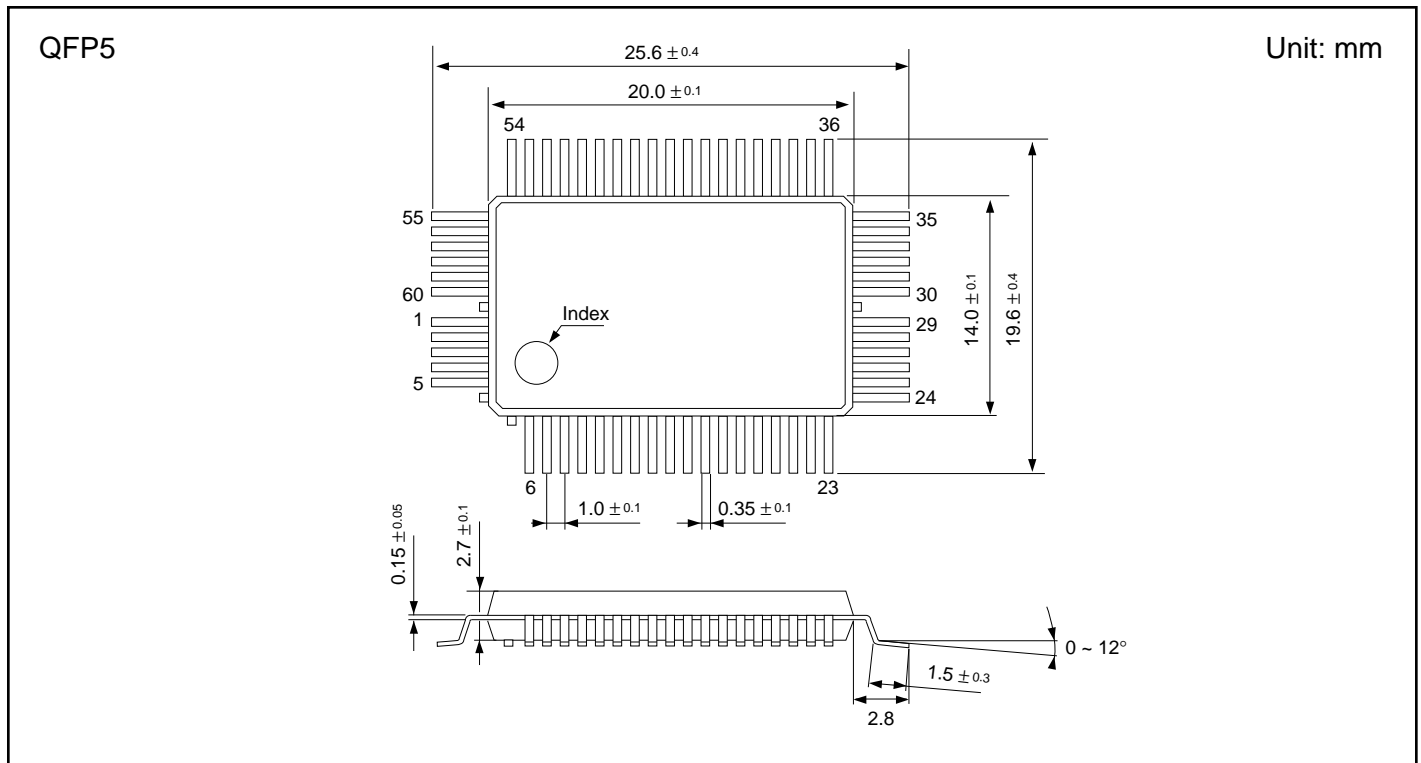

Figure 4. SED1330F<sub>BA</sub> and 1335F<sub>0A</sub> package dimensions

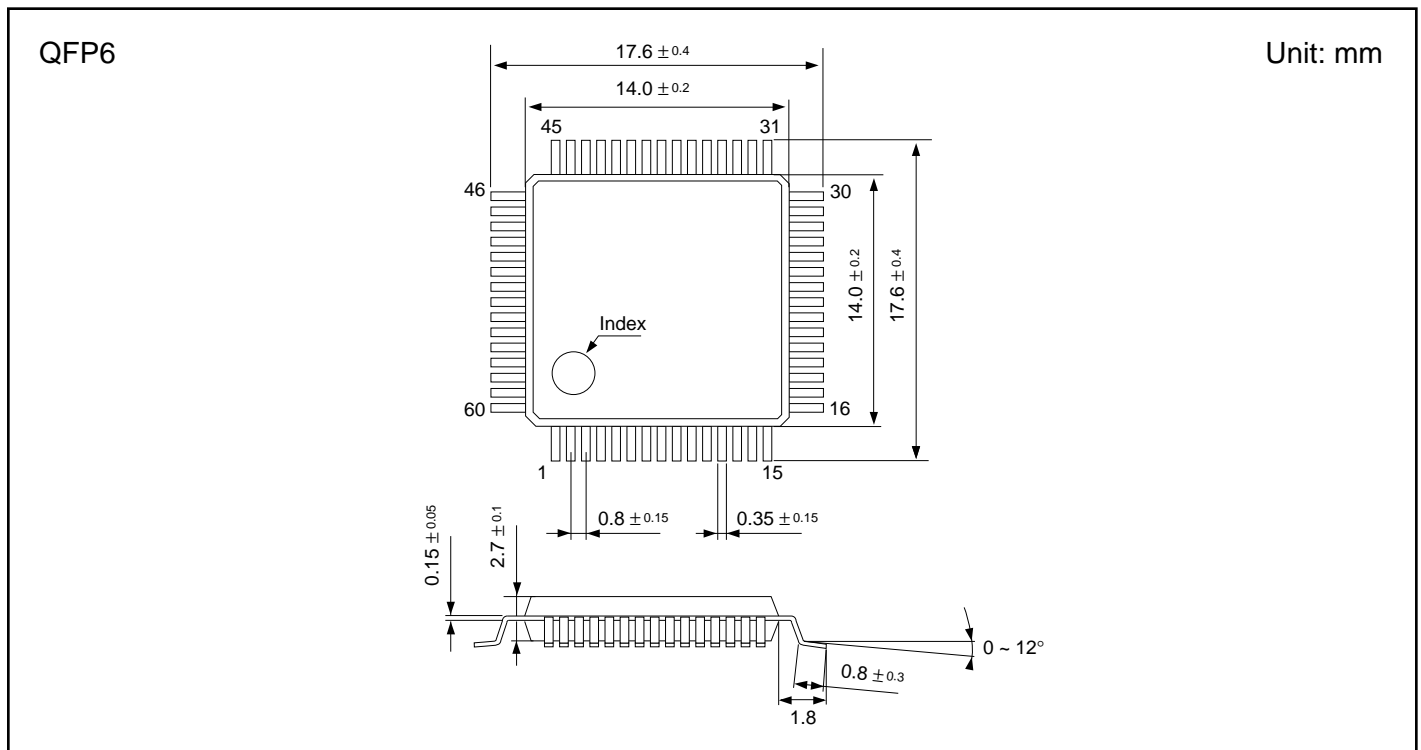

Figure 5. SED1330F<sub>BB</sub>, 1335F<sub>0B</sub> and SED1336F<sub>0A</sub>

**THIS PAGE INTENTIONALLY BLANK**



# **2.0**

## ***Pin Description***

## 2.0 Pin Description

## 2.1 SED1330FBA/BB Pin Summary

Name	Number		Type	Description
	SED1330F0A	SED1330FBB		
VA0 to VA15	27 to 28 30 to 43	50 to 59 1 to 6	Output	VRAM address bus
$\overline{VR/W}$	44	7	Output	VRAM write signal
$\overline{VCE}$	45	8	Output	Memory control signal
$\overline{RES}$	47	10	Input	Reset
NC	29, 46, 48, 49	9, 11, 12, 60	—	No connection
$\overline{RD}$	50	13	Input	8080 family: Read signal 6800 family: Enable clock (E)
$\overline{WR}$	51	14	Input	8080 family: Write signal 6800 family: R/ $\overline{W}$ signal
SEL2	52	15	Input	8080 or 6800 family interface select
SEL1	53	16	Input	8080 or 6800 family interface select
OSC1	54	17	Input	Oscillator connection
OSC2	55	18	Output	Oscillator connection
$\overline{CS}$	56	19	Input	Chip select
A0	57	20	Input	Data type select
VDD	58	21	Supply	4.5 to 5.5V supply
D0 to D7	59 to 60 1 to 6	22 to 29	Input/output	Data bus
XD0 to XD3	10 to 7	33 to 30	Output	X-driver data
XECL	11	34	Output	X-driver enable chain clock
XSCL	12	35	Output	X-driver data shift clock
Vss	13	36	Supply	Ground
LP	14	37	Output	Latch pulse
WF	15	38	Output	Frame signal
YDIS	16	39	Output	Power-down signal when display is blanked
YD	17	40	Output	Scan start pulse
YSCL	18	41	Output	Y-driver shift clock
VD0 to VD7	26 to 19	49 to 42	Input/output	VRAM data bus

## 2.0 Pin Description

## 2.2 SED1330F/1335F0A/0B Pin Summary

Name	Number		Type	Description
	SED1335F0A	SED1335F0B		
VA0 to VA15	27 to 28 30 to 43	50 to 59 1 to 6	Output	VRAM address bus
$\overline{VWR}$	44	7	Output	VRAM write signal
$\overline{VCE}$	45	8	Output	Memory control signal
$\overline{VRD}$	46	9	Output	VRAM read signal
$\overline{RES}$	47	10	Input	Reset
NC	29, 48, 49	11, 12, 60	—	No connection
$\overline{RD}$	50	13	Input	8080 family: Read signal 6800 family: Enable clock (E)
$\overline{WR}$	51	14	Input	8080 family: Write signal 6800 family: R/W signal
SEL2	52	15	Input	8080 or 6800 family interface select
SEL1	53	16	Input	8080 or 6800 family interface select
XG	54	17	Input	Oscillator connection
XD	55	18	Output	Oscillator connection
$\overline{CS}$	56	19	Input	Chip select
A0	57	20	Input	Data type select
VDD	58	21	Supply	2.7 to 5.5V supply
D0 to D7	59 to 60 1 to 6	22 to 29	Input/output	Data bus
XD0 to XD3	10 to 7	33 to 30	Output	X-driver data
XECL	11	34	Output	X-driver enable chain clock
XSCL	12	35	Output	X-driver data shift clock
Vss	13	36	Supply	Ground
LP	14	37	Output	Latch pulse
WF	15	38	Output	Frame signal
YDIS	16	39	Output	Power-down signal when display is blanked
YD	17	40	Output	Scan start pulse
YSCL	18	41	Output	Y-driver shift clock
VD0 to VD7	26 to 19	49 to 42	Input/output	VRAM data bus

## 2.3 SED1336F0A Pin Summary

Name	Number	Type	Description
VA0 to VA15	1 to 6 50 to 59	Output	VRAM address bus
$\overline{VWR}$	7	Output	VRAM write signal
$\overline{VCE}$	8	Output	Memory control signal
$\overline{VRD}$	9	Output	VRAM read signal
$\overline{RES}$	10	Input	Reset
NC	11, 60	—	No connection
CLO	12	Output	Clock output
$\overline{RD}$	13	Input	8080 family: Read signal 6800 family: Enable clock (E)
$\overline{WR}$	14	Input	8080 family: Write signal 6800 family: R/ $\overline{W}$ signal
NT/PL	15	Input	NTSC or PAL TV mode select
SEL1	16	Input	8080 or 6800 family interface select
OSC1	17	Input	Oscillator connection
OSC2	18	Output	Oscillator connection
$\overline{CS}$	19	Input	Chip select
A0	20	Input	Data type select
VDD	21	Supply	3.0 to 5.5V supply
D0 to D7	22 to 29	Input/output	Data bus
XD0 to XD3	30 to 33	Output	X-driver data
VSD	34	Output	Video data
XSCL	35	Output	Data shift clock
VSS	36	Supply	Ground
LP	37	Output	Latch pulse
WF	38	Output	Frame signal
YDIS	39	Output	Power-down signal when display is blanked
YD	40	Output	Scan start pulse
SNC	41	Output	TV sync signal
VD0 to VD7	42 to 49	Input/output	VRAM data bus

## 2.4 Pin Functions

### 2.4.1 Power Supply

Pin Name	Function
VDD	4.5 to 5.5V (SED1330F), 3.0 to 5.5V (SED1336F) or 2.7 to 5.5V (SED1330F/1335F) supply. This may be the same supply as the controlling microprocessor.
VSS	Ground

**Note:** The peak supply current drawn by the SED1330F/1335F/1336F may be up to ten times the average supply current. The power supply impedance must be kept as low as possible by ensuring that supply lines are sufficiently wide and by placing 0.47  $\mu$ F decoupling capacitors that have good high-frequency response near the device's supply pins.

### 2.4.2 Oscillator

Pin Name	Function
(OSC) XG	Crystal connection for internal oscillator (see Section 8.3). This pin can be driven by an external clock source that satisfies the timing specifications of the EXT $\phi$ 0 signal (see Section 4.3.6).
(OSC2) XD	Crystal connection for internal oscillator. Leave this pin open when using an external clock source.
CLO	Clock output (SED1336F only). Same phase as XG. Clock is output when system command P1 is executed. Output stops during system reset.

### 2.4.3 Microprocessor Interface

Pin Name	Function																					
D0 to D7	Tristate input/output pins. Connect these pins to an 8- or 16-bit microprocessor bus.																					
SEL1, SEL2	Microprocessor interface select pin. The SED1336F supports both 8080 family processors (such as the 8085 and Z80®) and 6800 family processors (such as the 6802 and 6809). <table border="1" data-bbox="332 1444 1511 1564"> <thead> <tr> <th>SEL1*</th> <th>SEL2</th> <th>Interface</th> <th>A0</th> <th><math>\overline{RD}</math></th> <th><math>\overline{WR}</math></th> <th><math>\overline{CS}</math></th> </tr> </thead> <tbody> <tr> <td>0</td> <td>0</td> <td>8080 family</td> <td>A0</td> <td><math>\overline{RD}</math></td> <td><math>\overline{WR}</math></td> <td><math>\overline{CS}</math></td> </tr> <tr> <td>1</td> <td>0</td> <td>6800 family</td> <td>A0</td> <td>E</td> <td>R/<math>\overline{W}</math></td> <td><math>\overline{CS}</math></td> </tr> </tbody> </table> <p>* SED1330F and SED1335F only</p>	SEL1*	SEL2	Interface	A0	$\overline{RD}$	$\overline{WR}$	$\overline{CS}$	0	0	8080 family	A0	$\overline{RD}$	$\overline{WR}$	$\overline{CS}$	1	0	6800 family	A0	E	R/ $\overline{W}$	$\overline{CS}$
SEL1*	SEL2	Interface	A0	$\overline{RD}$	$\overline{WR}$	$\overline{CS}$																
0	0	8080 family	A0	$\overline{RD}$	$\overline{WR}$	$\overline{CS}$																
1	0	6800 family	A0	E	R/ $\overline{W}$	$\overline{CS}$																

**Note:** SEL1 should be tied directly to V<sub>DD</sub> or V<sub>SS</sub> to prevent noise. If noise does appear on SEL1, decouple it to ground using a capacitor placed as close to the pin as possible.

Pin Name	Function																				
A0	A0, in conjunction with the $\overline{RD}$ and $\overline{WR}$ or $R/\overline{W}$ and E signals, controls the type of access to the SED1336F, as shown below. <b>8080 family interface</b>																				
	<table border="1"> <thead> <tr> <th>A0</th> <th><math>\overline{RD}</math></th> <th><math>\overline{WR}</math></th> <th>Function</th> </tr> </thead> <tbody> <tr> <td>0</td> <td>0</td> <td>1</td> <td>Status flag read</td> </tr> <tr> <td>1</td> <td>0</td> <td>1</td> <td>Display data and cursor address read</td> </tr> <tr> <td>0</td> <td>1</td> <td>0</td> <td>Display data and parameter write</td> </tr> <tr> <td>1</td> <td>1</td> <td>0</td> <td>Command write</td> </tr> </tbody> </table>	A0	$\overline{RD}$	$\overline{WR}$	Function	0	0	1	Status flag read	1	0	1	Display data and cursor address read	0	1	0	Display data and parameter write	1	1	0	Command write
	A0	$\overline{RD}$	$\overline{WR}$	Function																	
	0	0	1	Status flag read																	
	1	0	1	Display data and cursor address read																	
	0	1	0	Display data and parameter write																	
	1	1	0	Command write																	
	<b>6800 family interface</b>																				
	<table border="1"> <thead> <tr> <th>A0</th> <th>R/<math>\overline{W}</math></th> <th>E</th> <th>Function</th> </tr> </thead> <tbody> <tr> <td>0</td> <td>1</td> <td>1</td> <td>Status flag read</td> </tr> <tr> <td>1</td> <td>1</td> <td>1</td> <td>Display data and cursor address read</td> </tr> <tr> <td>0</td> <td>0</td> <td>1</td> <td>Display data and parameter write</td> </tr> <tr> <td>1</td> <td>0</td> <td>1</td> <td>Command write</td> </tr> </tbody> </table>	A0	R/ $\overline{W}$	E	Function	0	1	1	Status flag read	1	1	1	Display data and cursor address read	0	0	1	Display data and parameter write	1	0	1	Command write
	A0	R/ $\overline{W}$	E	Function																	
0	1	1	Status flag read																		
1	1	1	Display data and cursor address read																		
0	0	1	Display data and parameter write																		
1	0	1	Command write																		
$\overline{RD}$ or E	When the 8080 family interface is selected, this signal acts as the active-LOW read strobe. The SED1330F/1335F/1336F's output buffers are enabled when this signal is active. When the 6800 family interface is selected, this signal acts as the active-HIGH enable clock. Data is read from or written to the SED1330F/1335F/1336F when this clock goes HIGH.																				
$\overline{WR}$ or $R/\overline{W}$	When the 8080 family interface is selected, this signal acts as the active-LOW write strobe. The bus data is latched on the rising edge of this signal. When the 6800 family interface is selected, this signal acts as the read/write control signal. Data is read from the SED1330F/1335F/1336F if this signal is HIGH, and written to the SED1330F/1335F/1336F if it is LOW.																				
$\overline{CS}$	Chip select. This active-LOW input enables the SED1330F/1335F/1336F. It is usually connected to the output of an address decoder device that maps the SED1330F/1335F/1336F into the memory space of the controlling microprocessor.																				
$\overline{RES}$	This active-LOW input performs a hardware reset on the SED1330F/1335F/1336F. It is a Schmitt-trigger input for enhanced noise immunity; however, care should be taken to ensure that it is not triggered if the supply voltage is lowered.																				

### 2.4.4 Display Memory Control

The SED1330F/1335F/1336F can directly access static RAM and PROM. The designer may use a mixture of

these two types of memory to achieve an optimum trade-off between low cost and low power consumption.

Pin Name	Function
VA0 to VA15	16-bit display memory address. When accessing character generator RAM or ROM, VA0 to VA3, reflect the lower 4 bits of the row counter.
VD0 to VD7	8-bit tristate display memory data bus. These pins are enabled when $\overline{VR/W}$ is LOW.
$\overline{VR/W}$	Active-LOW display memory write control output (SED1330).
$\overline{VRD}$	Active-LOW display memory read control output (SED1335/6).
$\overline{VCE}$	Active-LOW static memory standby control signal. $\overline{VCE}$ can be used with $\overline{CS}$ .
$\overline{VWR}$	Active-LOW display memory write control output (SED1335/6).

### 2.4.5 LCD Drive Signals

In order to provide effective low-power drive for LCD matrixes, the SED1330F/1335F/1336F can directly control both the X- and Y-drivers using an enable chain.

Pin Name	Function
XD0 to XD3	4-bit X-driver (column drive) data outputs. Connect these outputs to the inputs of the X-driver chips.
XSCL	The falling edge of XSCL latches the data on XD0 to XD3 into the input shift registers of the X-drivers. To conserve power, this clock halts between LP and the start of the following display line (see Section 4.3.7).
XECL	The falling edge of XECL (SED1330F/1335F only) triggers the enable chain cascade for the X-drivers (SED1600/SED1180). Every 16th clock pulse is output to the next X-driver.
LP	LP latches the signal in the X-driver shift registers into the output data latches. LP is a falling-edge triggered signal, and pulses once every display line. Connect LP to the Y-driver shift clock on modules that use the SED1600 and SED1610 drivers.
WF	LCD panel AC drive output. The WF period is selected to be one of two values with SYSTEM SET command.
YSCL	The falling edge of YSCL (SED1330F/1335F only) latches the data on YD into the input shift registers of the Y-drivers. YSCL is not used with the SED1600, SED1610 or other driver ICs which use LP as the Y-driver shift clock.
YD	YD is the data pulse output for the Y drivers. It is active during the last line of each frame, and is shifted through the Y drivers one by one (by YSCL), to scan the display's common connections.
YDIS	Power-down output signal. YDIS is HIGH while the display drive outputs are active. YDIS goes LOW one or two frames after the sleep command is written to the SED1330F/1335F/1336F. All Y-driver outputs are forced to an intermediate level (de-selecting the display segments) to blank the display. In order to implement power-down operation in the LCD unit, the LCD power drive supplies must also be disabled when the display is disabled by YDIS.

**THIS PAGE INTENTIONALLY BLANK**



# **3.0**

## ***Command Description***

**THIS PAGE INTENTIONALLY BLANK**

## 3.0 Command Description

## 3.1 The Command Set

Table 1. The Command Set

Class	Command	Code												Hex	Command Description	Command Read Parameters	
		$\overline{RD}$	$\overline{WR}$	A0	D7	D6	D5	D4	D3	D2	D1	D0	No. of Bytes			Section	
System control	SYSTEM SET	1	0	1	0	1	0	0	0	0	0	0	0	40	Initialize device and display	8	3.2.1
	SLEEP IN	1	0	1	0	1	0	1	0	0	1	1	53	Enter standby mode	0	3.2.2	
Display control	DISP ON/OFF	1	0	1	0	1	0	1	1	0	0	D	58, 59	Enable and disable display and display flashing	1	3.3.1	
	SCROLL	1	0	1	0	1	0	0	0	1	0	0	44	Set display start address and display regions	10	3.3.2	
	CSRFORM	1	0	1	0	1	0	1	1	1	0	1	5D	Set cursor type	2	3.3.3	
	CGRAM ADR	1	0	1	0	1	0	1	1	1	0	0	5C	Set start address of character generator RAM	2	3.3.6	
	CSRDIR	1	0	1	0	1	0	0	1	1	CD 1	CD 0	4C to 4F	Set direction of cursor movement	0	3.3.4	
	HDOT SCR	1	0	1	0	1	0	1	1	0	1	0	5A	Set horizontal scroll position	1	3.3.7	
	OVLAY	1	0	1	0	1	0	1	1	0	1	1	5B	Set display overlay format	1	3.3.5	
Drawing control	CSRW	1	0	1	0	1	0	0	0	1	1	0	46	Set cursor address	2	3.4.1	
	CSRR	1	0	1	0	1	0	0	0	1	1	1	47	Read cursor address	2	3.4.2	
Memory control	MWRITE	1	0	1	0	1	0	0	0	0	1	0	42	Write to display memory	—	3.5.1	
	MREAD	1	0	1	0	1	0	0	0	0	1	1	43	Read from display memory	—	3.5.2	

**Notes:**

- In general, the internal registers of the SED1330F/1335F/1336F are modified as each command parameter is input. However, the microprocessor does not have to set all the parameters of a command and may send a new command before all parameters have been input. The internal registers for the parameters that have been input will have been changed but the remaining parameter registers are unchanged.
  - 2-byte parameters (where two bytes are treated as one data item) are handled as follows:
    - CSRW, CSRR: Each byte is processed individually. The microprocessor may read or write just the low byte of the cursor address.
    - SYSTEM SET, SCROLL, CGRAM ADR: Both parameter bytes are processed together. If the command is changed after half of the parameter has been input, the single byte is ignored.
- APL and APH are 2-byte parameters, but are treated as two 1-byte parameters.

## 3.2 System Control Commands

### 3.2.1 SYSTEM SET

Initializes the device, sets the window sizes, and selects the LCD interface format. Since the command sets the basic operating parameters of the SED1330F/

1335F/1336F, an incorrect SYSTEM SET command may cause other commands to operate incorrectly.

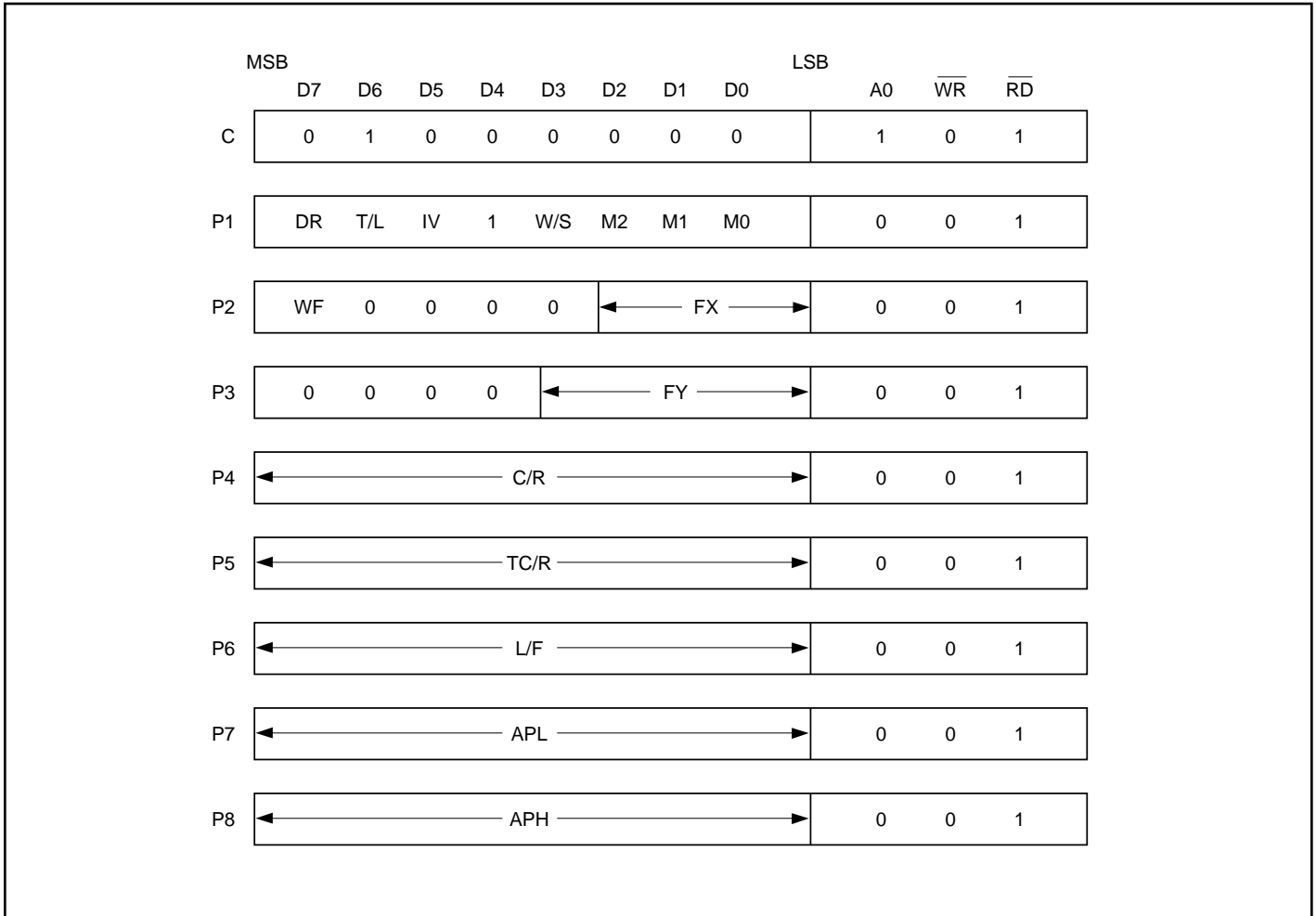

Figure 7. SYSTEM SET instruction

**3.2.1.1 C**

This control byte performs the following:

1. Resets the internal timing generator
2. Disables the display
3. Cancels sleep mode

Parameters following P1 are not needed if only canceling sleep mode.

**3.2.1.2 M0**

Selects the internal or external character generator ROM. The internal character generator ROM contains 160, 5×7 pixel characters. These characters are fixed at fabrication by the metalization mask. The external character generator ROM can contain up to 256 user-defined characters.

**M0 = 0:** Internal CG ROM

**M0 = 1:** External CG ROM

Note that if the CG ROM address space overlaps the display memory address space, that portion of the display memory cannot be written to.

**3.2.1.3 M1**

Selects the CG RAM area for user-definable characters. The CG RAM codes are selected from the 64 codes shown in Figure 59.

**M1 = 0:** CG RAM1; 32 char

The CG RAM1 and CG RAM2 address spaces are not contiguous, the CG RAM1 address space is treated

as character generator RAM, and the CG RAM2 address space is treated as character generator ROM.

**M1 = 1:** 64 char CG RAM + CG RAM2

The CG RAM1 and CG RAM2 address spaces are contiguous and are both treated as character generator RAM.

**3.2.1.4 M2**

Selects the height of the character defined in external CG ROM and CG RAM. Characters more than 16 pixels high can be displayed by creating a bitmap for each portion of each character and using the SED1330F/1335F/1336F's graphics mode to reposition them.

**M2 = 0:** 8-pixel character height (2716 or equivalent ROM)

**M2 = 1:** 16-pixel character height (2732 or equivalent ROM)

**3.2.1.5 W/S**

Selects the LCD drive method.

**W/S = 0:** Single-panel drive

**W/S = 1:** Dual-panel drive

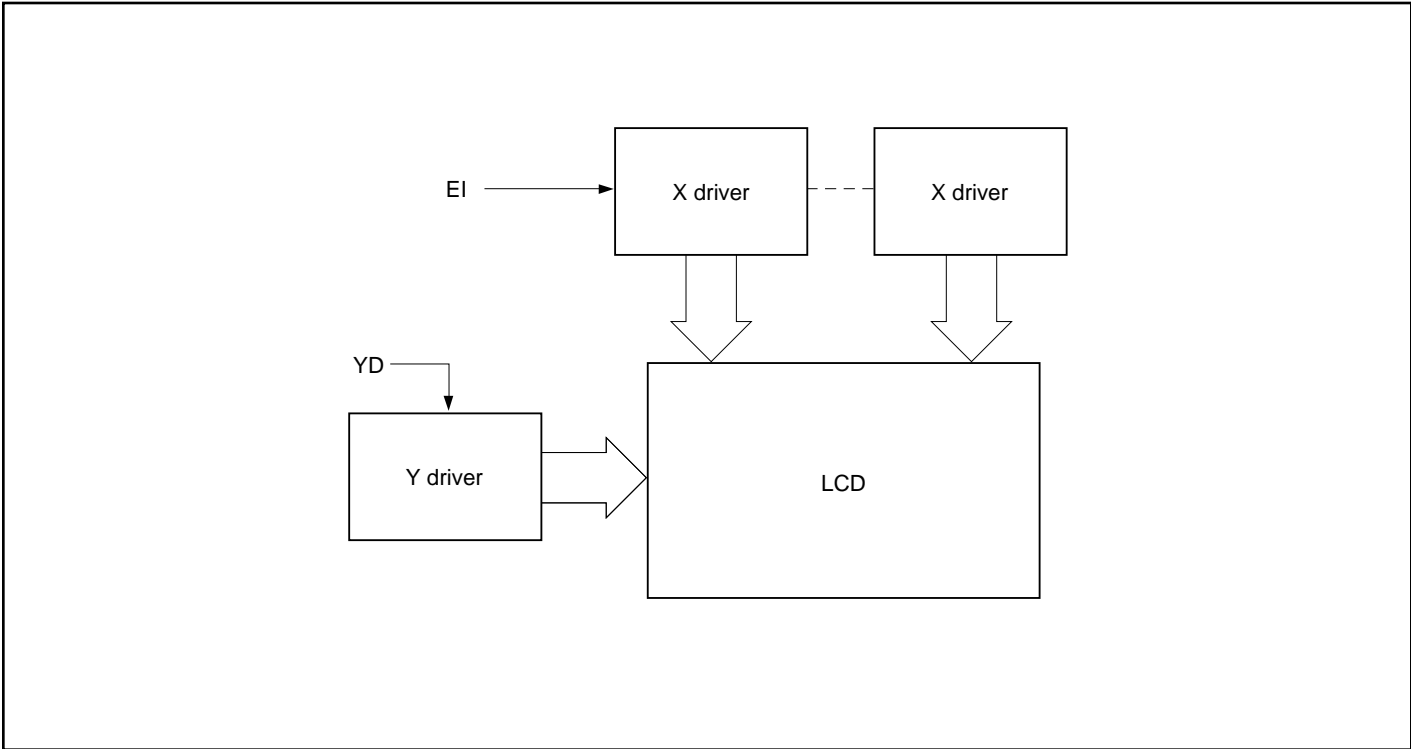

Figure 8. Single-panel display

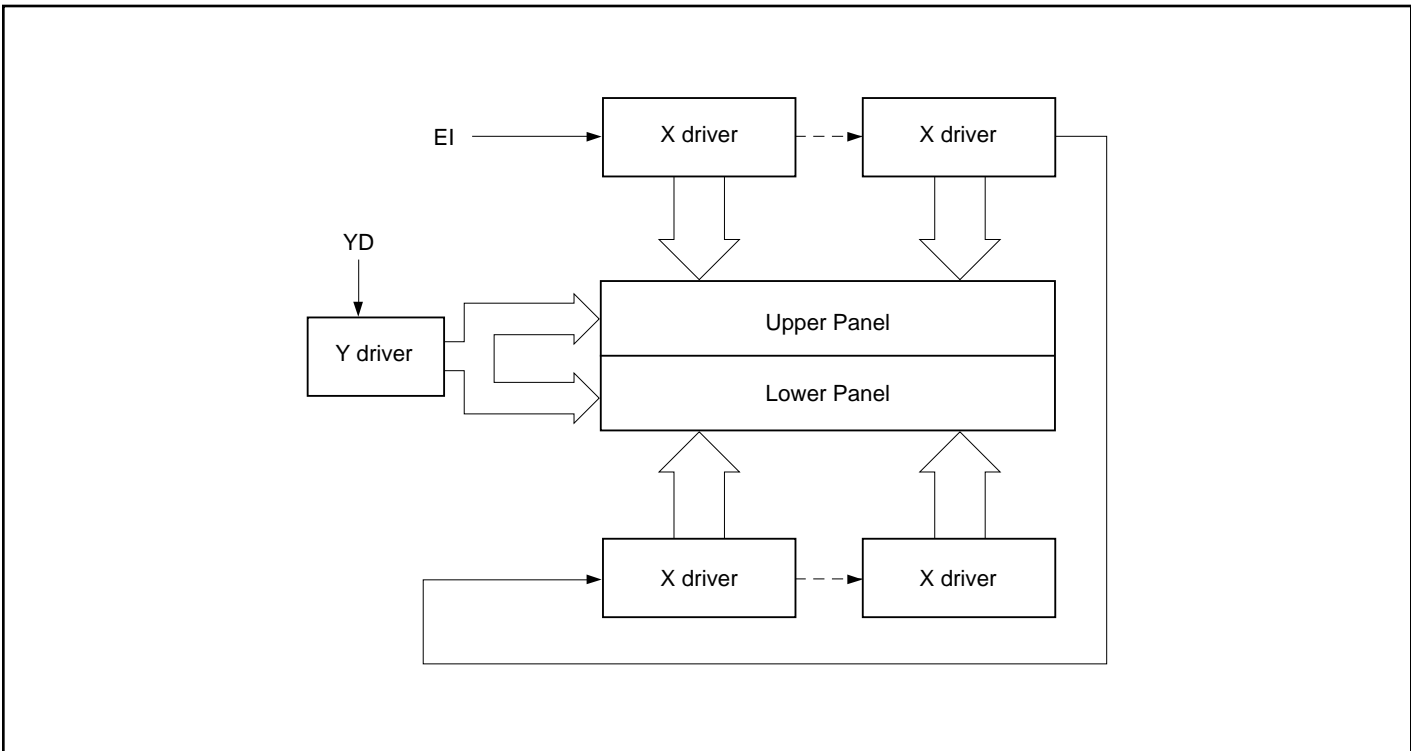

Figure 9. Dual-panel display

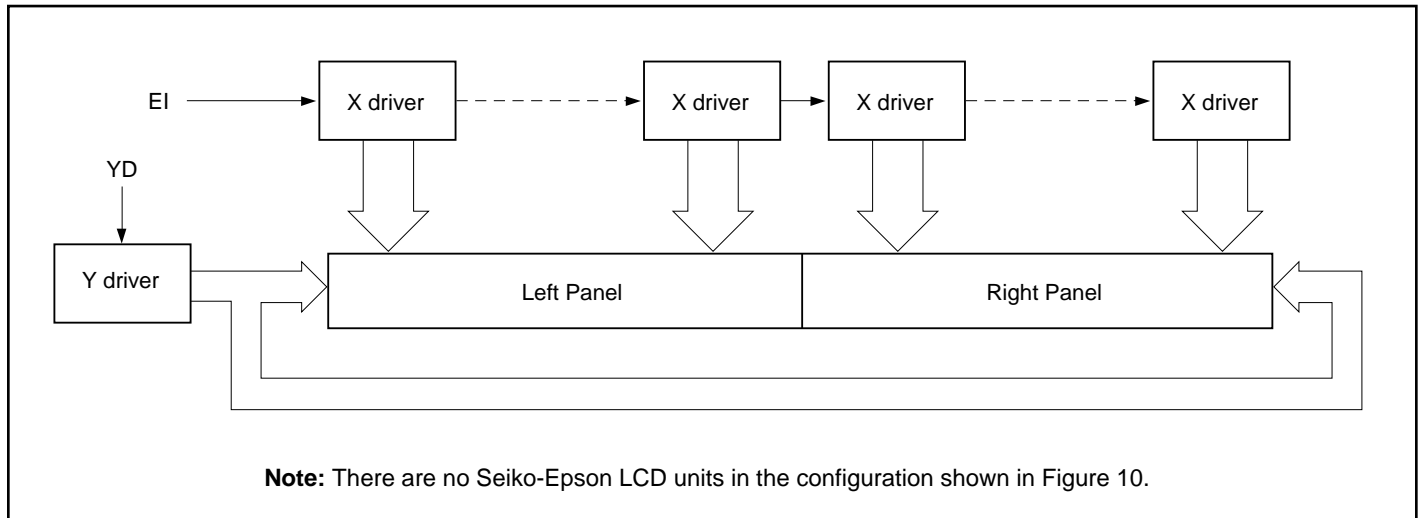

Figure 10. Left-and-right two-panel display

Table 3. LCD parameters

Parameter	W/S = 0		W/S = 1	
	IV = 1	IV = 0	IV = 1	IV = 0
C/R	C/R	C/R	C/R	C/R
TC/R	TC/R	TC/R (see note 1)	TC/R	TC/R
L/F	L/F	L/F	L/F	L/F
SL1	00H to L/F	00H to L/F + 1 (see note 2)	(L/F) / 2	(L/F) / 2
SL2	00H to L/F	00H to L/F + 1 (see note 2)	(L/F) / 2	(L/F) / 2
SAD1	First screen block	First screen block	First screen block	First screen block
SAD2	Second screen block	Second screen block	Second screen block	Second screen block
SAD3	Third screen block	Third screen block	Third screen block	Third screen block
SAD4	Invalid	Invalid	Fourth screen block	Fourth screen block
Cursor movement range	Continuous movement over whole screen		Above-and-below configuration: continuous movement over whole screen	

**Notes:**

1. See table 31 (page 105) for further details on setting the C/R and TC/R parameters when using the HDOT SCR command.
2. The value of SL when IV = 0 is equal to the value of SL when IV = 1, plus one.

## 3.2.1.6 IV

Screen origin compensation for inverse display. IV is usually set to 1.

The best way of displaying inverted characters is to Exclusive-OR the text layer with the graphics background layer. However, inverted characters at the top or left of the screen are difficult to read as the character origin is at the top-left of its bitmap and there are no background pixels either above or to the left of these characters.

The IV flag causes the SED1330F/1335F/1336F to offset the text screen against the graphics back layer by one vertical pixel. Use the horizontal pixel scroll function (HDOT SCR) to shift the text screen 1 to 7 pixels to the right. All characters will then have the necessary surrounding background pixels that ensure easy reading of the inverted characters.

See Section 5.5 for information on scrolling.

- IV = 0:** Screen top-line correction
- IV = 1:** No screen top-line correction (no offset)

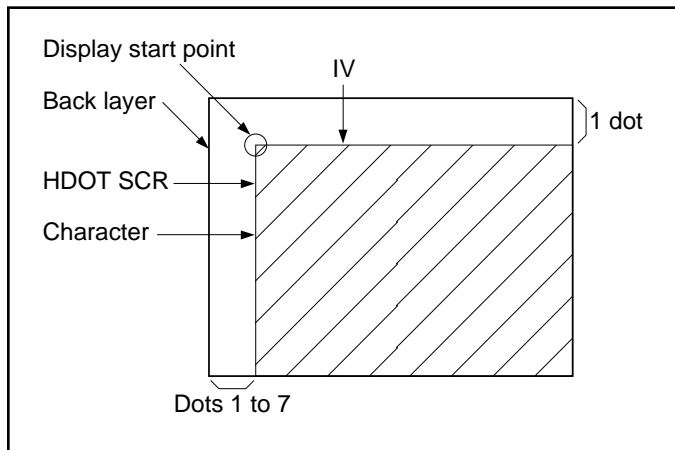

Figure 11. IV and HDOT SCR adjustment

## 3.2.1.7 T/L

Selects TV or LCD mode. When TV mode is selected, the TV sync generator circuit is ON.

- T/L = 0:** LCD mode
- T/L = 1:** TV mode

## 3.2.1.8 DR

Selects output of an additional shift-clock cycle for every 64 pixels. The extra cycles are required for correct operation of the enable chain when using a two-panel display.

- DR = 0:** Normal operation
- DR = 1:** Additional shift-clock cycles

## 3.2.1.9 FX

Sets the width, in pixels, of the character field. The character width in pixels is equal to FX + 1, where FX can range from 00 to 07H inclusive. If data bit 3 is set (FX is in the range 08 to 0FH) and an 8-pixel font is used, a space is inserted between characters. Note that the maximum character width in TV mode is eight pixels.

Table 4. Horizontal character size selection

HEX	FX				[FX] character width (pixels)
	D3	D2	D1	D0	
00	0	0	0	0	1
01	0	0	0	1	2
↓	↓	↓	↓	↓	↓
07	0	1	1	1	8

Since the SED1330F/1335F/1336F handles display data in 8-bit units, characters larger than 8 pixels wide must be formed from 8-pixel segments. As Figure 12 shows, the remainder of the second eight bits are not displayed. This also applies to the second screen layer.

In graphics mode, the normal character field is also eight pixels. If a wider character field is used, any remainder in the second eight bits is not displayed.



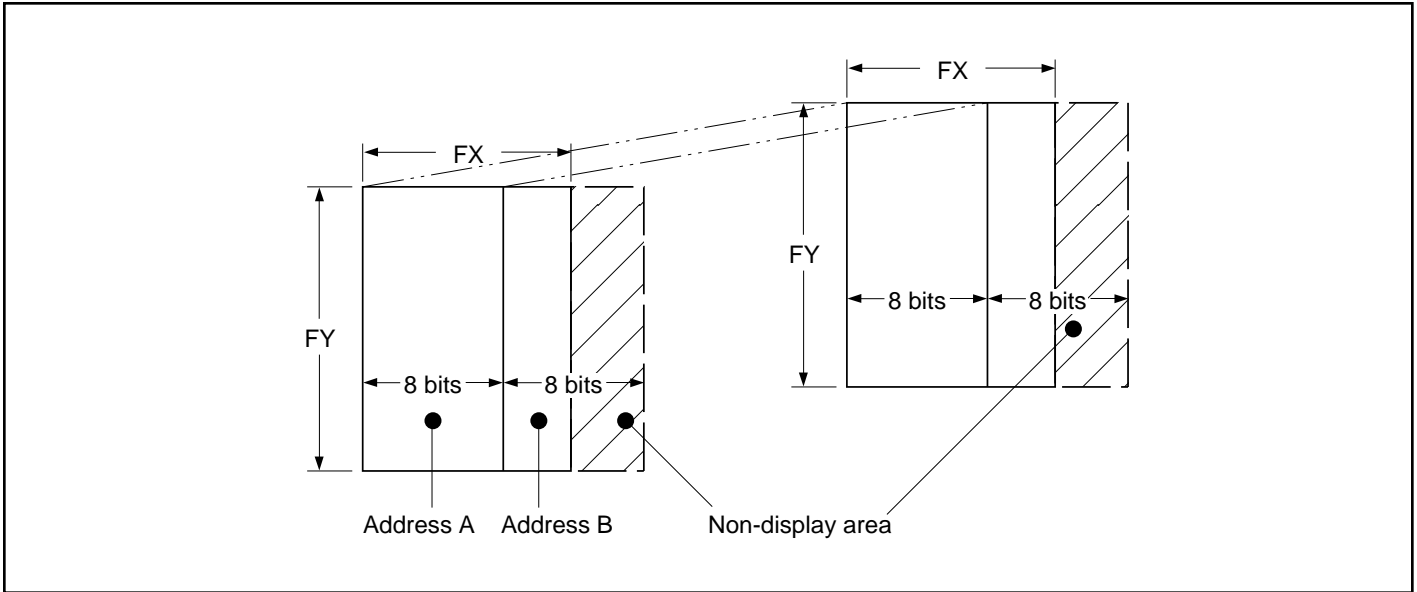

Figure 12. FX and FY display addresses

**3.2.1.10 WF**

Selects the AC frame drive waveform period. WF is usually set to 1.

- WF = 0:** 16-line AC drive
- WF = 1:** two-frame AC drive

In two-frame AC drive, the WF period is twice the frame period.

In 16-line AC drive, WF inverts every 16 lines.

Although 16-line AC drive gives a more readable display, horizontal lines may appear when using high LCD drive voltages or at high viewing angles.

**3.2.1.11 FY**

Sets the height, in pixels, of the character. The height in pixels is equal to FY + 1.

FY can range from 00 to 0FH inclusive.

Set FY to zero (vertical size equals one) when in graphics mode.

**Table 5. Vertical character size selection**

HEX	FY				[FY] character height (pixels)
	D3	D2	D1	D0	
00	0	0	0	0	1
01	0	0	0	1	2
↓	↓	↓	↓	↓	↓
07	0	1	1	1	8
↓	↓	↓	↓	↓	↓
0E	1	1	1	0	15
0F	1	1	1	1	16

### 3.2.1.12 C/R

Sets the address range covered by one display line, that is, the number of characters less one, multiplied by the number of horizontal bytes per character.

C/R can range from 0 to 239.

For example, if the character width is 10 pixels, then the address range is equal to twice the number of

characters, less 2. See Section 9.1.1 for the calculation of C/R.

[C/R] cannot be set to a value greater than the address range. It can, however, be set smaller than the address range, in which case the excess display area is blank. The number of excess pixels must not exceed 64.

**Table 6. Display line address range**

C/R									[C/R] bytes per display line
HEX	D7	D6	D5	D4	D3	D2	D1	D0	
00	0	0	0	0	0	0	0	0	1
01	0	0	0	0	0	0	0	1	2
↓	↓	↓	↓	↓	↓	↓	↓	↓	↓
4F	0	1	0	0	1	1	1	1	80
↓	↓	↓	↓	↓	↓	↓	↓	↓	↓
EE	1	1	1	0	1	1	1	0	239
EF	1	1	1	0	1	1	1	1	240

### 3.2.1.13 TC/R

Sets the length, including horizontal blanking, of one line. The line length is equal to TC/R + 1, where TC/R can range from 0 to 255.

TC/R must be greater than or equal to C/R + 4. Provided this condition is satisfied, [TC/R] can be set

according to the equation given in section 9.1.1 in order to hold the frame period constant and minimize jitter for any given main oscillator frequency,  $f_{OSC}$ .

**Table 7. Line length selection**

TC/R									[TC/R] line length (bytes)
HEX	D7	D6	D5	D4	D3	D2	D1	D0	
00	0	0	0	0	0	0	0	0	1
01	0	0	0	0	0	0	0	1	2
↓	↓	↓	↓	↓	↓	↓	↓	↓	↓
52	0	1	0	1	0	0	1	0	83
↓	↓	↓	↓	↓	↓	↓	↓	↓	↓
FE	1	1	1	1	1	1	1	0	255
FF	1	1	1	1	1	1	1	1	256

3.2.1.14 L/F

Sets the height, in lines, of a frame. The height in lines is equal to L/F + 1, where L/F can range from 0 to 255.

If W/S is set to 1, selecting two-screen display, the number of lines must be even and L/F must, therefore, be an odd number.

Table 8. Frame height selection

L/F									[L/F] lines per frame
HEX	D7	D6	D5	D4	D3	D2	D1	D0	
00	0	0	0	0	0	0	0	0	1
01	0	0	0	0	0	0	0	1	2
↓	↓	↓	↓	↓	↓	↓	↓	↓	↓
7F	0	1	1	1	1	1	1	1	128
↓	↓	↓	↓	↓	↓	↓	↓	↓	↓
FE	1	1	1	1	1	1	1	0	255
FF	1	1	1	1	1	1	1	1	256

Table 9. Frame heights and compatible LCD units

Number of lines [LF]	Panel Duty Cycle
64	1/64
128	1/64

Table 10. Horizontal address range

Hex code				[AP] addresses per line
APH		APL		
0	0	0	0	0
0	0	0	1	1
↓	↓	↓	↓	↓
0	0	5	0	80
↓	↓	↓	↓	↓
F	F	F	E	2 <sup>16</sup> – 2
F	F	F	F	2 <sup>16</sup> – 1

3.2.1.15 AP

Defines the horizontal address range of the virtual screen. APL is the least significant byte of the address.

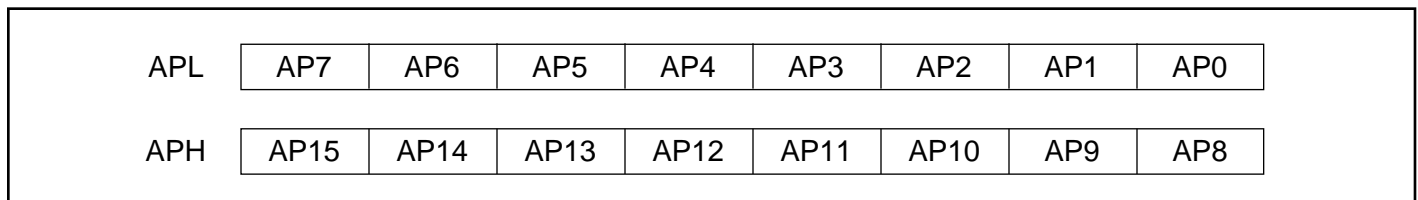

Figure 13. AP parameters

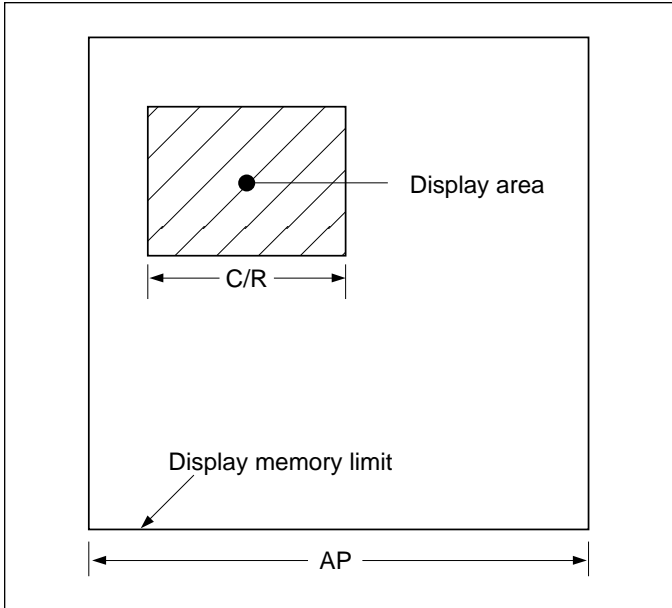

Figure 14. AP and C/R relationship

#### 3.2.2 SLEEP IN

Places the system in standby mode. This command has no parameter bytes. At least one blank frame after receiving this command, the SED1330F/1335F/1336F halts all internal operations, including the oscillator, and enters the sleep mode. Blank data is sent to the X-drivers, and the Y-drivers have their bias supplies turned off by the YDIS signal. Using the YDIS signal to disable the Y-drivers guards against any spurious displays.

The internal registers of the SED1330F/1335/1336F maintain their values during the sleep mode. The display memory control pins maintain their logic levels to ensure that the display memory is not corrupted.

The SED1330F/1335F/1336F can be removed from the sleep state by sending the SYSTEM SET command with only the P1 parameter. The DISP ON command should be sent next to enable the display.

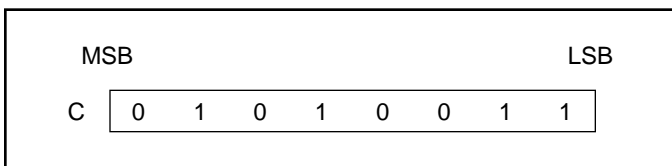

Figure 15. SLEEP IN instruction

1. The YDIS signal goes LOW between one and two frames after the SLEEP IN command is received. Since YDIS forces all display driver outputs to go to the deselected output voltage, YDIS can be used as a power-down signal for the LCD unit. This can be done by having YDIS turn off the relatively high-power LCD drive supplies at the same time as it blanks the display.
2. Since all internal clocks in the SED1330F/1335F/1336F are halted while in the sleep state, a DC voltage will be applied to the LCD panel if the LCD drive supplies remain on.

If reliability is a prime consideration, turn off the LCD drive supplies before issuing the SLEEP IN command.

3. Note that, although the bus lines become high impedance in the sleep state, pull-up or pull-down resistors on the bus line will force these lines to a known state.

### 3.3 Display Control Commands

#### 3.3.1 DISP ON/OFF

Turns the whole display on or off. The single-byte parameter enables and disables the cursor and layered screens, and sets the cursor and screen flash rates. The cursor can be set to flash over one character or over a whole line.

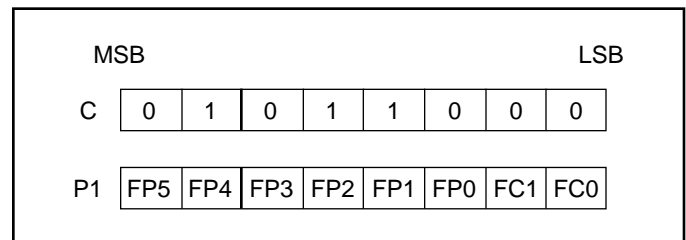

Figure 16. DISP ON/OFF parameters

3.3.1.1 D

Turns the display ON or OFF. The D bit takes precedence over the FP bits in the parameter.

- D = 0: Display OFF
- D = 1: Display ON

3.3.1.2 FC

Enables/disables the cursor and sets the flash rate. The cursor flashes with a 70% duty cycle (ON/OFF).

Table 11. Cursor flash rate selection

FC1	FC0	Cursor display	
0	0	OFF (blank)	
0	1	ON	No flashing
1	0		Flash at $f_{FR}/32$ Hz (approx. 2 Hz)
1	1		Flash at $f_{FR}/64$ Hz (approx. 1 Hz)

**Note:** As the MWRITE command always enables the cursor, the cursor position can be checked even when performing consecutive writes to display memory while the cursor is flashing.

3.3.1.3 FP

Each pair of bits in FP sets the attributes of one screen block, as follows.

Table 12. Screen block attribute selection

FP1	FP0	First screen block (SAD1)	
FP3	FP2	Second screen block (SAD2, SAD4). See note.	
FP5	FP4	Third screen block (SAD3)	
0	0	OFF (blank)	
0	1	ON	No flashing
1	0		Flash at $f_{FR}/32$ Hz (approx. 2 Hz)
1	1		Flash at $f_{FR}/4$ Hz (approx. 16 Hz)

**Note:** If SAD4 is enabled by setting W/S to 1, FP3 and FP2 control both SAD2 and SAD4. The attributes of SAD2 and SAD4 cannot be set independently.

3.3.2 SCROLL

3.3.2.1 C

Sets the scroll start address and the number of lines per scroll block. Parameters P1 to P10 can be omitted if not required. The parameters must be entered sequentially as shown in Figure 17.

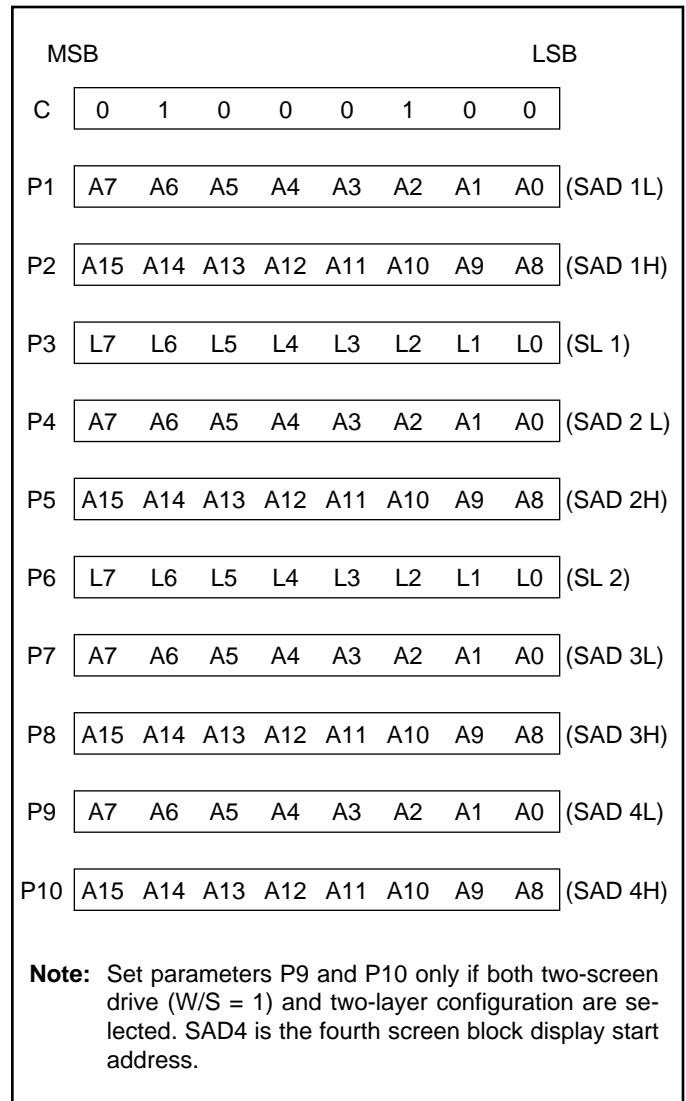

Figure 17. SCROLL instruction parameters

Table 13. Screen block start address selection

SL1, SL2									[SL] screen lines
HEX	L7	L6	L5	L4	L3	L2	L1	L0	
00	0	0	0	0	0	0	0	0	1
01	0	0	0	0	0	0	0	1	2
↓	↓	↓	↓	↓	↓	↓	↓	↓	↓
7F	0	1	1	1	1	1	1	1	128
↓	↓	↓	↓	↓	↓	↓	↓	↓	↓
FE	1	1	1	1	1	1	1	0	255
FF	1	1	1	1	1	1	1	1	256

3.3.2.2 SL1, SL2

SL1 and SL2 set the number of lines per scrolling screen. The number of lines is SL1 or SL2 plus one.

The relationship between SAD, SL and the display mode is described below.

Table 14. Text display mode

W/S	Screen	First Layer	Second Layer
0	First screen block	SAD1	SAD2
	Second screen block	SL1	SL2
	Third screen block (partitioned screen)	SAD3 (see note 1) Set both SL1 and SL2 to L/F + 1 if not using a partitioned screen.	
	Screen configuration example:		
	<p>The diagram illustrates a screen configuration example. It shows a vertical stack of three main display areas. The top area is labeled 'Character display page 1'. Below it is a smaller area labeled 'Graphics display page 2'. The bottom area is labeled 'Character display page 3'. To the left of these areas, three arrows point to the start addresses: SAD1 points to the top of 'Character display page 1', SAD2 points to the top of 'Graphics display page 2', and SAD3 points to the top of 'Character display page 3'. To the right, two vertical lines represent scrolling limits: SL1 is aligned with the top of 'Character display page 1', and SL2 is aligned with the top of 'Character display page 3'. At the bottom, two arrows point to the layers: 'Layer 1' points to the bottom of the entire stack, and 'Layer 2' points to the bottom of 'Character display page 3'.</p>		

(continued)

Table 14. Text display mode (continued)

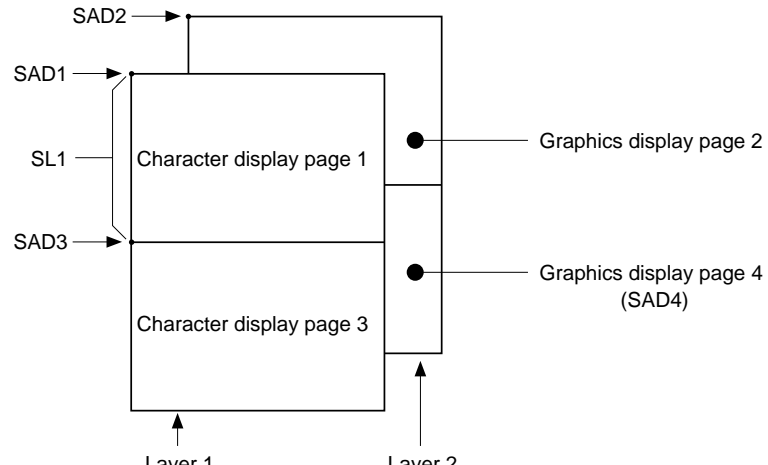
W/S	Screen	First Layer	Second Layer
	Upper screen	SAD1 SL1	SAD2 SL2
	Lower screen	SAD3 (see note 2)	SAD4 (see note 2)
Set both SL1 and SL2 to $((L/F) / 2 + 1)$			
1	Screen configuration example:  		

**Notes:**

1. SAD3 has the same value as either SAD1 or SAD2, whichever has the least number of lines (set by SL1 and SL2).
2. Since the parameters corresponding to SL3 and SL4 are fixed by L/F, they do not have to be set in this mode.

Table 15. Graphics display mode

W/S	Screen	First Layer	Second Layer	Third Layer
0	Two-layer composition	SAD1 SL1	SAD2 SL2	
	Upper screen	SAD3 (see note 3) Set both SL1 and SL2 to L/F + 1 if not using a partitioned screen		
Screen configuration example: 				
0	Three-layer configuration	SAD1 SL1 = L/F + 1	SAD2 SL2 = L/F + 1	SAD3 —
	Screen configuration example: 			



Table 15. Graphics display mode (continued)

W/S	Screen	First Layer	Second Layer	Third Layer
1	Upper screen	SAD1 SL1	SAD2 SL2	—
	Lower screen	SAD3 (see note 2)	SAD4 (see note 2)	—
	Set both SL1 and SL2 to $((L/F) / 2 + 1)$ Screen configuration example (see note 3):			

Notes:

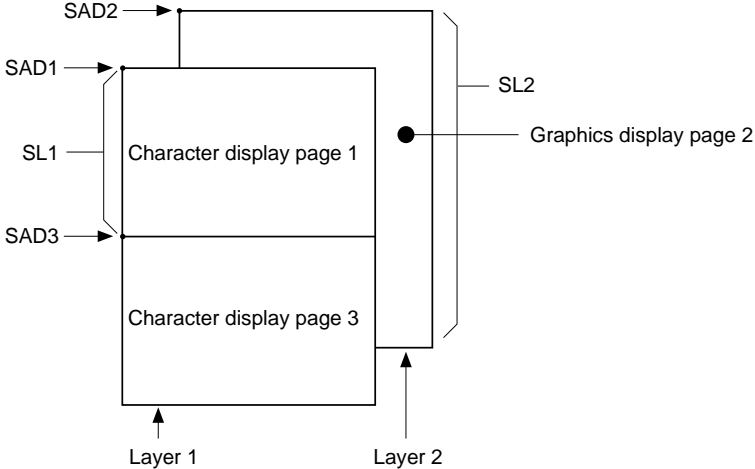
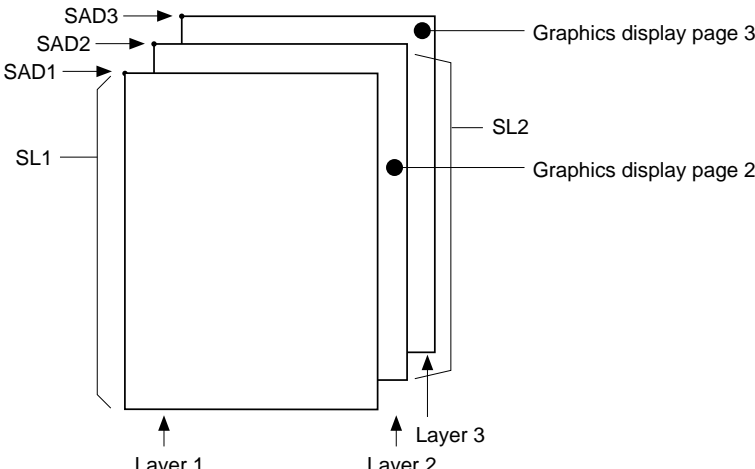
1. SAD3 has the same value as either SAD1 or SAD2, whichever has the least number of lines (set by SL1 and SL2).
2. Since the parameters corresponding to SL3 and SL4 are fixed by L/F, they do not have to be set.
3. If, and only if, W/S = 1, the differences between SL1 and  $(L/F + 1) / 2$ , and between SL2 and  $(L/F + 1) / 2$ , are blanked.

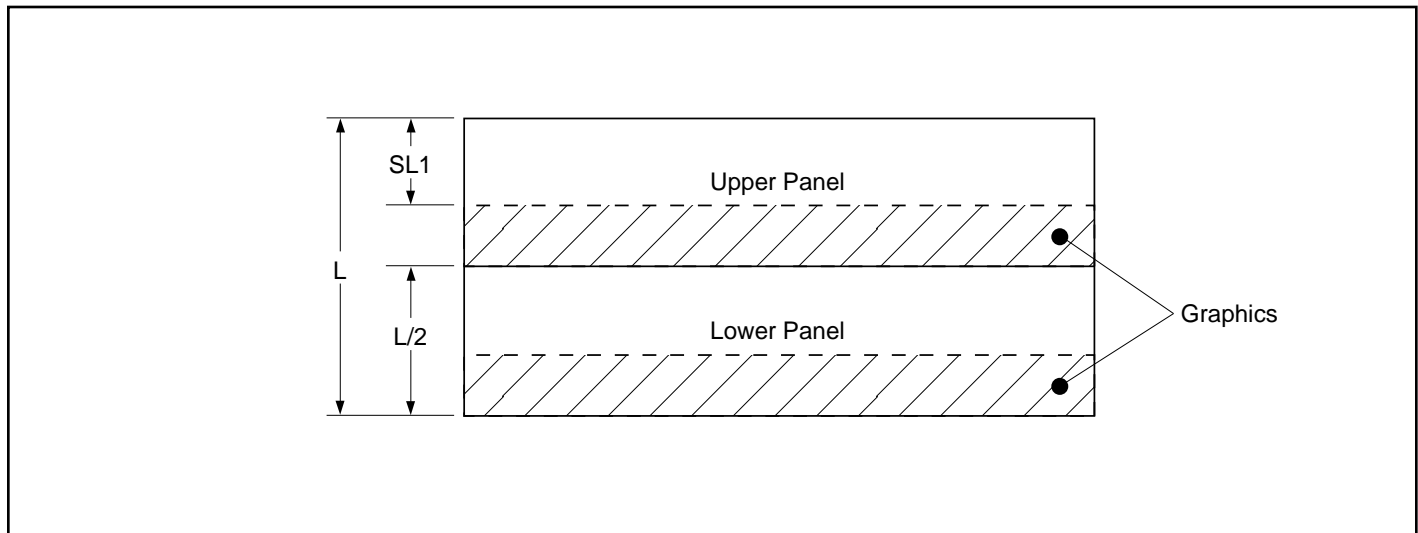

Figure 18. Two-panel display height

## 3.3.3 CSRFORM

Sets the cursor size and display mode. Although the cursor is normally only used in text displays, it may also be used in graphics displays when displaying special characters.

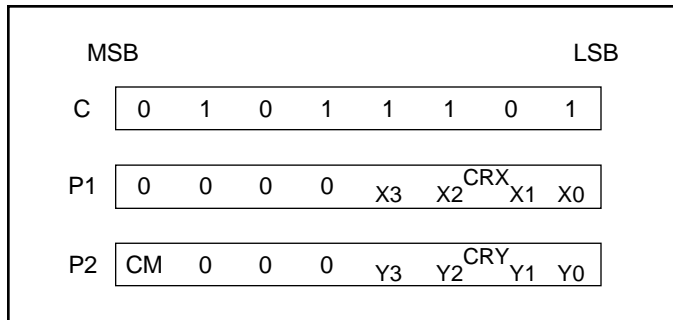

Figure 19. CSRFORM parameter bytes

### 3.3.3.1 CRX

Sets the horizontal size of the cursor from the character origin. CRX is equal to the cursor size less one. CRX must be less than or equal to FX.

Table 16. Horizontal cursor size selection

HEX	CRX				[CRX] cursor width (pixels)
	X3	X2	X1	X0	
0	0	0	0	0	1
1	0	0	0	1	2
↓	↓	↓	↓	↓	↓
8	1	0	0	0	9
↓	↓	↓	↓	↓	↓
E	1	1	1	0	15
F	1	1	1	1	16

### 3.3.3.2 CRY

Sets the location of an underscored cursor in lines, from the character origin. When using a block cursor, CRY sets the vertical size of the cursor from the character origin. CRY is equal to the number of lines less one.

Table 17. Cursor height selection

HEX	CRY				[CRY] cursor height (lines)
	Y3	Y2	Y1	Y0	
0	0	0	0	0	illegal
1	0	0	0	1	2
↓	↓	↓	↓	↓	↓
8	1	0	0	0	9
↓	↓	↓	↓	↓	↓
E	1	1	1	0	15
F	1	1	1	1	16

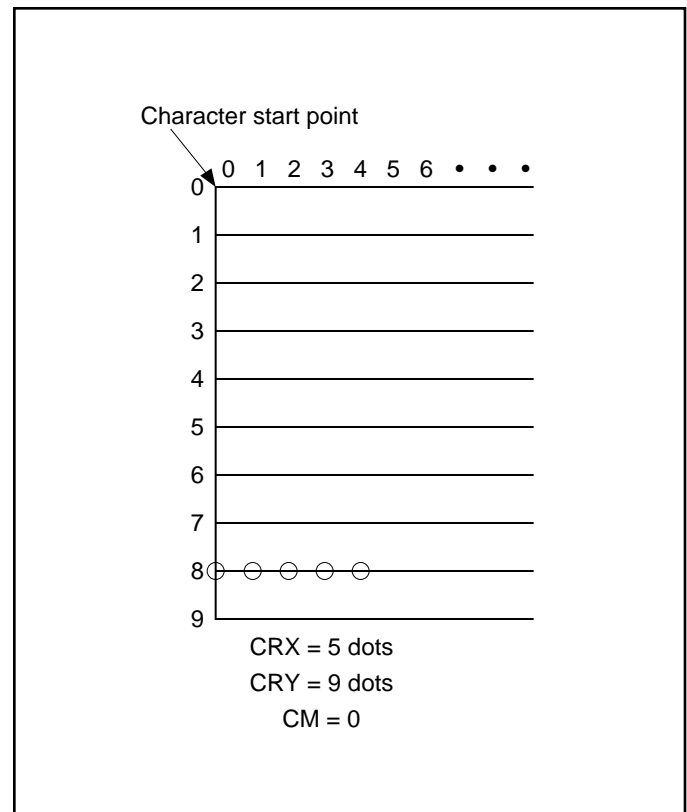

Figure 20. Cursor size and position

**3.3.3.3 CM**

Sets the cursor display mode. Always set CM to 1 when in graphics mode.

**CM = 0:** Underline cursor

**CM = 1:** Block cursor

**3.3.4 CSRDIR**

Sets the direction of automatic cursor increment. The cursor can move left or right one character, or up or down by the number of bytes specified by the address pitch, AP.

When reading from and writing to display memory, this automatic cursor increment controls the display memory address increment on each read or write.

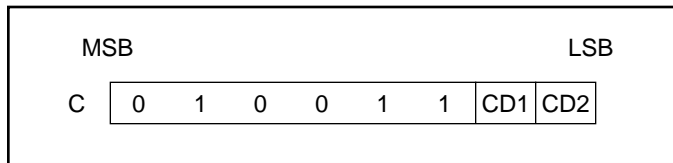

Figure 21. CSRDIR parameters

**Table 18. Cursor shift direction**

C	CD1	CD0	Shift direction
4CH	0	0	Right
4DH	0	1	Left
4EH	1	0	Up
4FH	1	1	Down

**Note:** Since the cursor moves in address units even if FX ≥ 9, the cursor address increment must be preset for movement in character units. See Section 5.3.

**3.3.5 OVLAY**

Selects layered screen composition and screen text/graphics mode.

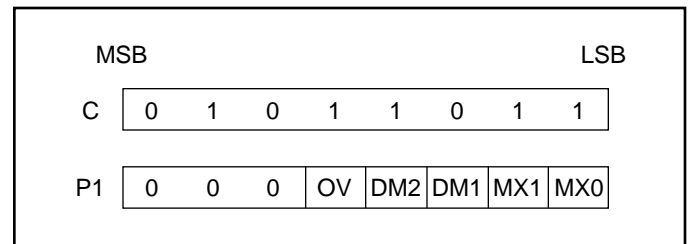

Figure 23. OVLAY parameter

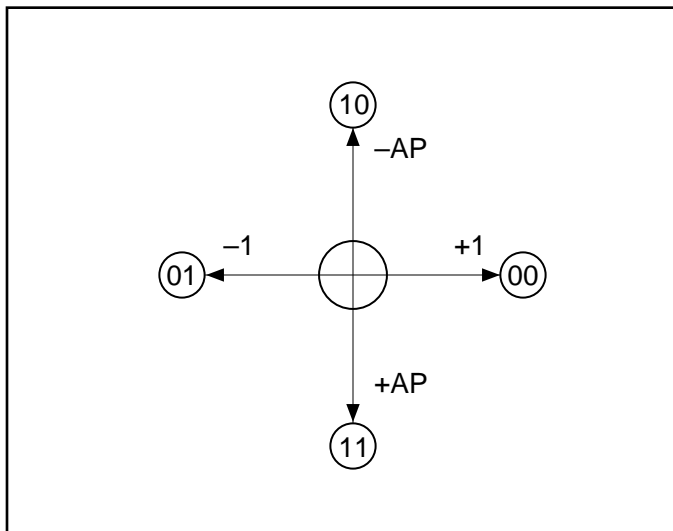

Figure 22. Cursor direction

**3.3.5.1 MX0, MX1**

MX0 and MX1 set the layered screen composition method, which can be either OR, AND, Exclusive-OR or Priority-OR. Since the screen composition is organized in layers and not by screen blocks, when using a layer divided into two screen blocks, different composition methods cannot be specified for the individual screen blocks.

The Priority-OR mode is the same as the OR mode unless flashing of individual screens is used.

**Table 19. Composition method selection**

MX1	MX0	Function	Composition Method	Applications
0	0	$L1 \cup L2 \cup L3$	OR	Underlining, rules, mixed text and graphics
0	1	$(L1 \oplus L2) \cup L3$	Exclusive-OR	Inverted characters, flashing regions, underlining
1	0	$(L1 \cap L2) \cup L3$	AND	Simple animation, three-dimensional appearance
1	1	$L1 > L2 > L3$	Priority-OR	

**Notes:**

L1: First layer (text or graphics). If text is selected, layer L3 cannot be used.

L2: Second layer (graphics only)

L3: Third layer (graphics only)

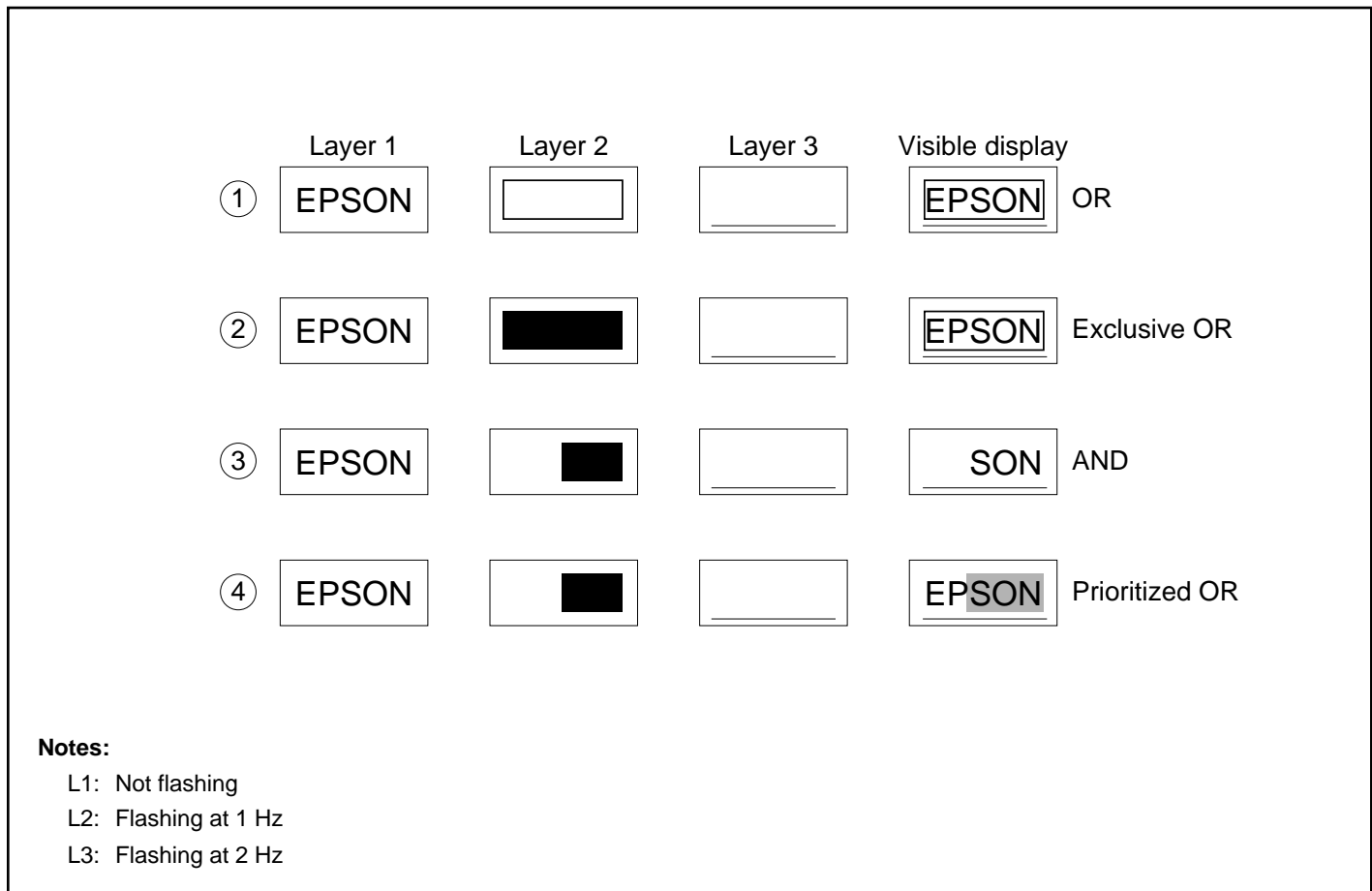

Figure 24. Combined layer display

3.3.5.2 DM1, DM2

DM1 and DM2 specify the display mode of screen blocks 1 and 3, respectively.

**DM1/2 = 0:** Text mode

**DM1/2 = 1:** Graphics mode

**Note 1:** Screen blocks 2 and 4 can only display graphics.

**Note 2:** DM1 and DM2 must be the same, regardless of the setting of W/S.

3.3.5.3 OV

Specifies two- or three-layer composition in graphics mode.

**OV = 0:** Two-layer composition

**OV = 1:** Three-layer composition

Set OV to 0 for mixed text and graphics mode.

3.3.6 CGRAM ADR

Specifies the CG RAM start address.

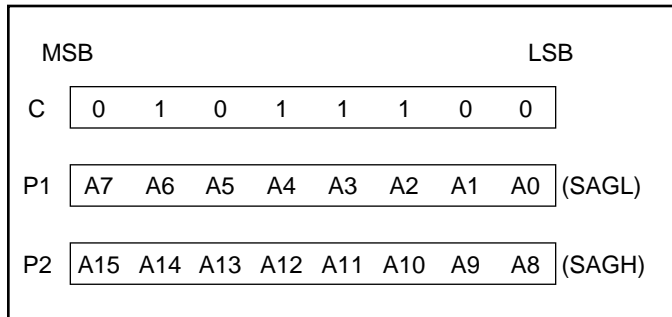

Figure 25. CGRAM ADR parameters

**Note:** See Section 6 for information on the SAG parameters.

3.3.7 HDOT SCR

While the scroll command only allows scrolling by characters, HDOT SCR allows the screen to be scrolled horizontally by pixels. HDOT SCR cannot be used on individual layers.

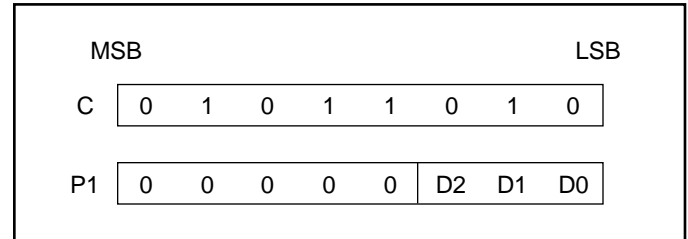

Figure 26. HDOT SCR parameters

3.3.7.1 D0 to D2

Specifies the number of pixels to scroll. The C/R parameter has to be set to one more than the number of horizontal characters before using HDOT SCR. Smooth scrolling can be simulated if the controlling microprocessor repeatedly issues the HDOT SCR command to the SED1330F/1335F/1336F. See Section 5.5 for more information on scrolling the display.

Table 20. Scroll step selection

HEX	P1			Number of pixels to scroll
	D2	D1	D0	
00	0	0	0	0
01	0	0	1	1
02	0	1	0	2
↓	↓	↓	↓	↓
06	1	1	0	6
07	1	1	1	7

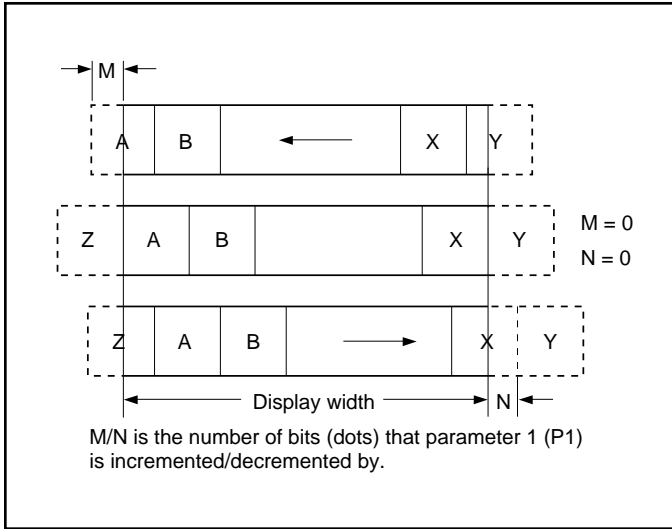

Figure 27. Horizontal scrolling

## 3.4 Drawing Control Commands

### 3.4.1 CSRW

The 16-bit cursor address register contains the display memory of the data at the cursor position as shown in Figure 28.

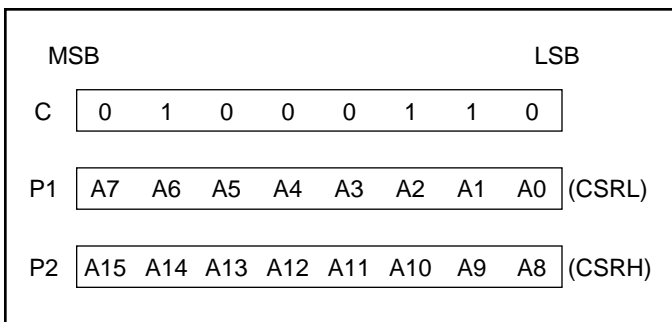

Figure 28. CSRW parameters

Note that the microprocessor cannot directly access the display memory.

The MREAD and MWRITE commands use the address in this register.

The cursor address register can only be modified by the CSRW command, and by the automatic increment after an MREAD or MWRITE command. It is not affected by display scrolling.

If a new address is not set, display memory accesses will be from the last set address or the address after previous automatic increments.

### 3.4.2 CSRR

Reads from the cursor address register. After issuing the command, the data read address is read twice, for the low byte and then the high byte of the register.

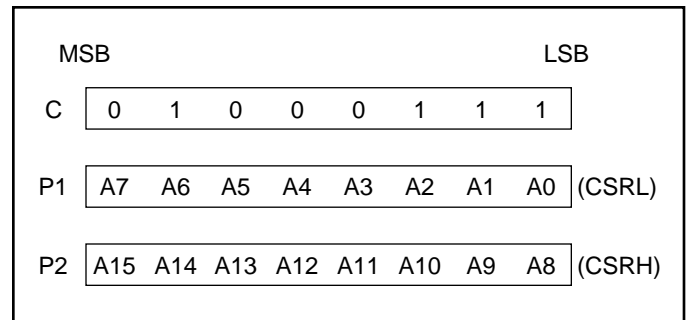

Figure 29. CSRR parameters

3.5 Memory Control Commands

3.5.1 MWRITE

The microprocessor may write a sequence of data bytes to display memory by issuing the MREAD command and then writing the bytes to the SED1330F/1335F/1336F. There is no need for further MWRITE commands or for the microprocessor to update the cursor address register after each byte as the cursor address is automatically incremented by the amount set with CSRDIR, in preparation for the next data write.

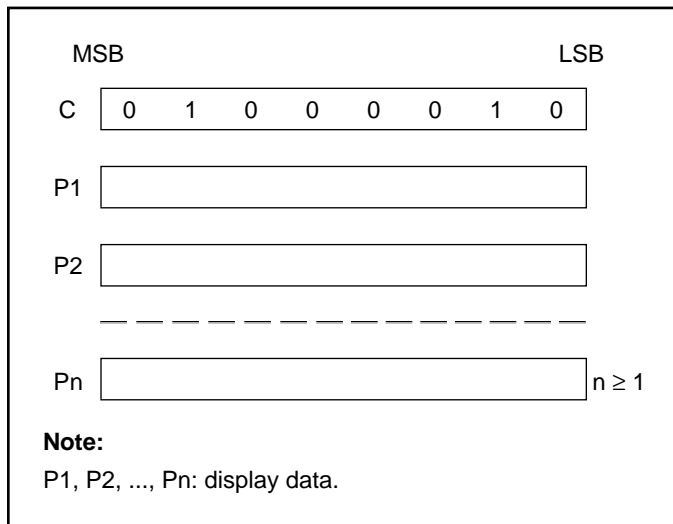

Figure 30. MWRITE parameters

3.5.2 MREAD

Puts the SED1330F/1335F/1336F into the data output state. On the MREAD command, the display memory data at the cursor address is read into a buffer in the SED1330F/1335F/1336F.

Each time the microprocessor reads the buffer, the cursor address is incremented by the amount set by CSRDIR and the next data byte fetched from memory, so a sequence of data bytes may be read without further MREAD commands or by updating the cursor address register.

If the cursor is displayed, the read data will be from two positions ahead of the cursor.

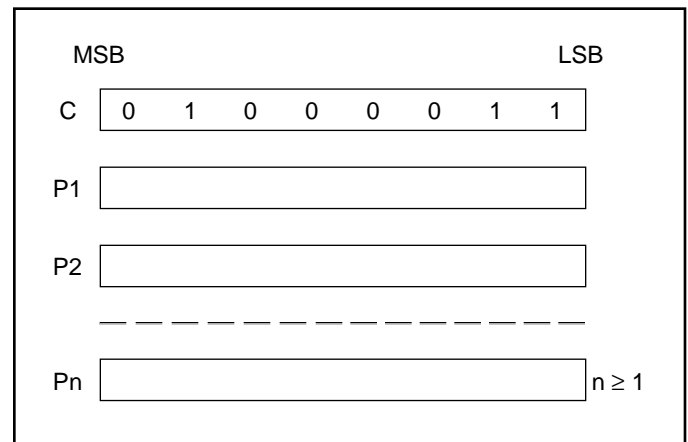

Figure 31. MREAD parameters

**THIS PAGE INTENTIONALLY BLANK**



# **4.0**

## ***Specifications***

**THIS PAGE INTENTIONALLY BLANK**

## 4.0 Specifications

### 4.1 Absolute Maximum Ratings

#### 4.1.1 SED1330

Parameter	Symbol	Rating	Unit
Supply voltage range	VDD	-0.3 to 7.0	V
Input voltage range	VIN	-0.5 to VDD + 0.5	V
Power dissipation	PD	300	mW
Operating temperature range	T <sub>opr</sub>	-20 to 75	°C
Storage temperature range	T <sub>stg</sub>	-65 to 150	°C
Soldering temperature (10 seconds). See note 1.	T <sub>solder</sub>	260	°C

#### 4.1.2 SED1335/SED1336

Parameter	Symbol	Rating	Unit
Supply voltage range	VDD	-0.3 to 7.0	V
Input voltage range	VIN	-0.3 to VDD + 0.3	V
Power dissipation	PD	300	mW
Operating temperature range	T <sub>opr</sub>	-20 to 75	°C
Storage temperature range	T <sub>stg</sub>	-65 to 150	°C
Soldering temperature (10 seconds). See note 1.	T <sub>solder</sub>	260	°C

#### Notes:

1. The humidity resistance of the flat package may be reduced if the package is immersed in solder. Use a soldering technique that does not heatstress the package.
2. If the power supply has a high impedance, a large voltage differential can occur between the input and supply voltages. Take appropriate care with the power supply and the layout of the supply lines. (See Section 2.3.)
3. All supply voltages are referenced to V<sub>SS</sub> = 0V.

## 4.2 SED 1330 Electrical Characteristics

VDD = 5V ±10%, VSS = 0V, Ta = -20 to 75°C

Parameter	Symbol	Condition	Rating			Unit
			min	typ	max	
Supply voltage	VDD		4.5	5.0	5.5	V
Register data retention voltage	VOH		2.0	—	5.5	V
Input leakage current	ILI	VI = VDD.	—	0.05	2.0	μA
Output leakage current	ILO	VI = VSS.	—	0.10	5.0	μA
Operating supply current	Iopr	See note 4.	—	8	12	mA
Quiescent supply current	IQ	VOSC1 = VCS = VRD = VDD	—	0.05	20.0	μA
Oscillator frequency	fOSC	Measured at OSC1	1.0	—	10.0	MHz
External clock frequency	fCL		—	—	10.0	MHz
Oscillator feedback resistance	Rf		0.5	1.0	5.0	MΩ
<b>TTL</b>						
HIGH-level input voltage	VIHT	See note 1.	2.2	—	VDD + 0.3	V
LOW-level input voltage	VILT	See note 1.	-0.3	—	0.8	V
HIGH-level output voltage	VOHT	IOH = -5.0 mA. See note 1.	2.4	—	—	V
LOW-level output voltage	VOLT	IOL = 5.0 mA. See note 1.	—	—	0.4	V
<b>CMOS</b>						
HIGH-level input voltage	VIHC	See note 2.	0.8VDD	—	—	V
LOW-level input voltage	VILC	See note 2.	—	—	0.2VDD	V
HIGH-level output voltage	VOHC	IOH = -1.6 mA. See note 2.	VDD - 0.4	—	—	V
LOW-level output voltage	VOLC	IOH = 1.6 mA. See note 2.	—	—	0.4	V
<b>Schmitt-trigger</b>						
Rising-edge threshold voltage	VT+	See note 3.	0.5VDD	0.7VDD	0.8VDD	V
Falling-edge threshold voltage	VT-	See note 3.	0.2VDD	0.3VDD	0.5VDD	V

**Notes:**

1. D0 to D7, A0, CS, RD, WR, VD0 to VD7, VA0 to VA15, VRW and VCE are TTL-level inputs.
2. SEL1, SEL2 and OSC1 are CMOS-level inputs. YD, XD0 to XD3, XSCL, YECL, LP, WF, YSCL, YDIS and CLO are CMOS-level outputs.
3. RES is a Schmitt-trigger input. The pulsewidth on RES must be at least 200 μs. Note that pulses of more than a few seconds will cause DC voltages to be applied to the LCD panel.
4. fosc = 10 MHz, no load (no display memory), internal character generator, 256 × 200 pixel display. The operating supply current can be reduced by approximately 1 mA by setting both CLO and the display OFF.

## 4.3 SED1335/1336 Electrical Characteristics

VDD = 4.5 to 5.5V, VSS = 0V, Ta = -20 to 75°C

Parameter	Symbol	Condition	Rating			Unit
			min	typ	max	
Supply voltage	VDD		4.5	5.0	5.5	V
Register data retention voltage	VOH		2.0	—	6.0	V
Input leakage current	ILI	VI = VDD. See note 6.	—	0.05	2.0	μA
Output leakage current	ILO	VI = VSS. See note 6.	—	0.10	5.0	μA
Operating supply current	Iopr	See note 4.	—	11	15	mA
Quiescent supply current	IQ	Sleep mode, VOSC1 = VCS = VRD = VDD	—	0.05	20.0	μA
Oscillator frequency	fOSC	Measured at crystal, 47.5% duty cycle. See note 7.	1.0	—	10.0	MHz
External clock frequency	fCL		1.0	—	10.0	MHz
Oscillator feedback resistance	Rf		0.5	1.0	3.0	MΩ
<b>TTL</b>						
HIGH-level input voltage	VIHT	See note 1.	0.5VDD	—	VDD	V
LOW-level input voltage	VILT	See note 1.	VSS	—	0.2VDD	V
HIGH-level output voltage	VOHT	IOH = -5.0 mA. See note 1.	2.4	—	—	V
LOW-level output voltage	VOLT	IOI = 5.0 mA. See note 1.	—	—	VSS + 0.4	V
<b>CMOS</b>						
HIGH-level input voltage	VIHC	See note 2.	0.8VDD	—	VDD	V
LOW-level input voltage	VILC	See note 2.	VSS	—	0.2VDD	V
HIGH-level output voltage	VOHC	IOH = -2.0 mA. See note 2.	VDD - 0.4	—	—	V
LOW-level output voltage	VOLC	IOH = 1.6 mA. See note 2.	—	—	VSS + 0.4	V
<b>Open-drain</b>						
LOW-level output voltage	VOLN	IOI = 6.0 mA. See note 5.	—	—	VSS + 0.4	V
<b>Schmitt-trigger</b>						
Rising-edge threshold voltage	VT+	See note 3.	0.5VDD	0.7VDD	0.8VDD	V
Falling-edge threshold voltage	VT-	See note 3.	0.2VDD	0.3VDD	0.5VDD	V

**Notes:**

- D0 to D7, A0,  $\overline{CS}$ ,  $\overline{RD}$ ,  $\overline{WR}$ , VD0 to VD7, VA0 to VA15, VRD, VWR and VCE are TTL-level inputs.
- SEL1 and NT/PL are CMOS-level inputs. YD, XD0 to XD3, XSCL, XECL, LP, WF, YSCL, YDIS and CLO are CMOS-level outputs.
- $\overline{RES}$  is a Schmitt-trigger input. The pulsewidth on  $\overline{RES}$  must be at least 200 μs. Note that pulses of more than a few seconds will cause DC voltages to be applied to the LCD panel.
- fosc = 10 MHz, no load (no display memory), internal character generator, 256 × 200 pixel display. The operating supply current can be reduced by approximately 1 mA by setting both CLO and the display OFF.

## 4.4 SED1330 Timing Diagrams

### 4.4.1 System bus READ/WRITE timing I (8080)

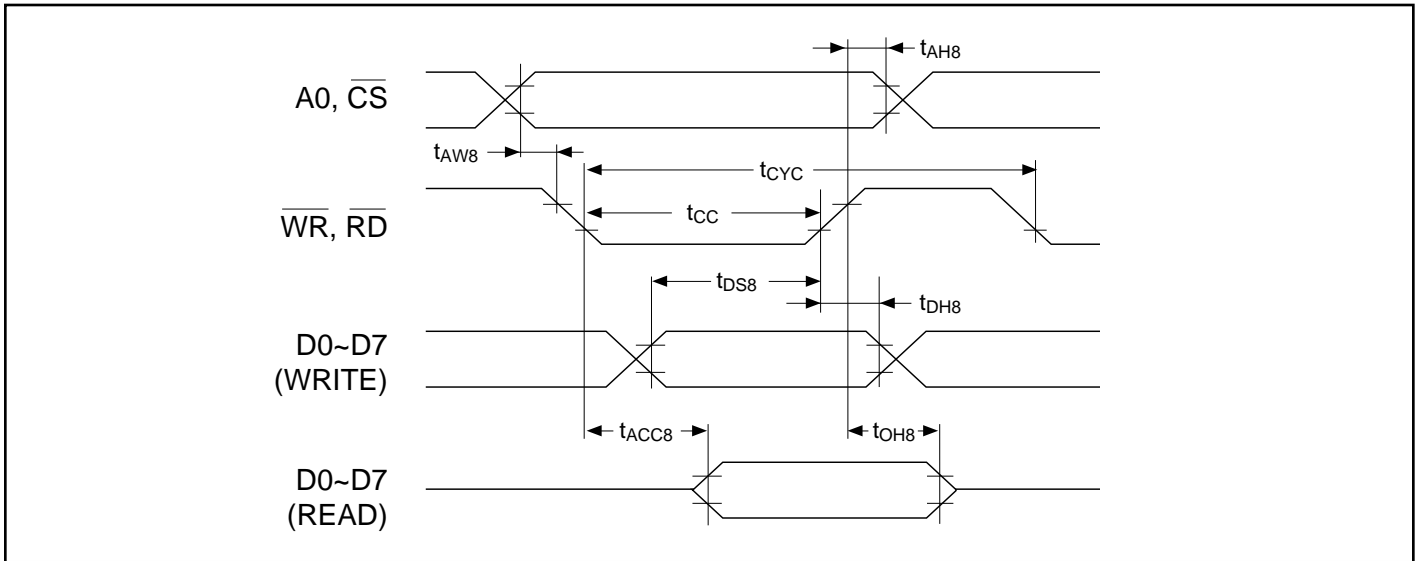

Figure 32. System bus READ/WRITE timing I (8080)

#### 4.4.1.1 SED1330F

Ta = -20 to 75°C

Signal	Symbol	Parameter	Rating		Unit	Condition
			min	max		
A0, $\overline{CS}$	tAH8	Address hold time	10	—	ns	CL = 100 pF
	tAW8	Address setup time	30	—	ns	
$\overline{WR}$ , $\overline{RD}$	tCYC	System cycle time	(1)	—	ns	
	tCC	Strobe pulsewidth	220	—	ns	
D0 to D7	tDS8	Data setup time	120	—	ns	
	tDH8	Data hold time	10	—	ns	
	tACC8	$\overline{RD}$ access time	—	120	ns	
	tOH8	Output disable time	10	50	ns	

**Note:**  $t_{CYC} = 2t_C + t_{CC} + t_{CEA} + 75 > t_{ACV} + 245$ :  
 memory control/movement control commands:  
 $= 4t_C + t_{CC} + 30$ :  
 all other commands:

4.4 SED1330 Timing Diagrams

4.4.2 System bus READ/WRITE timing II (6800)

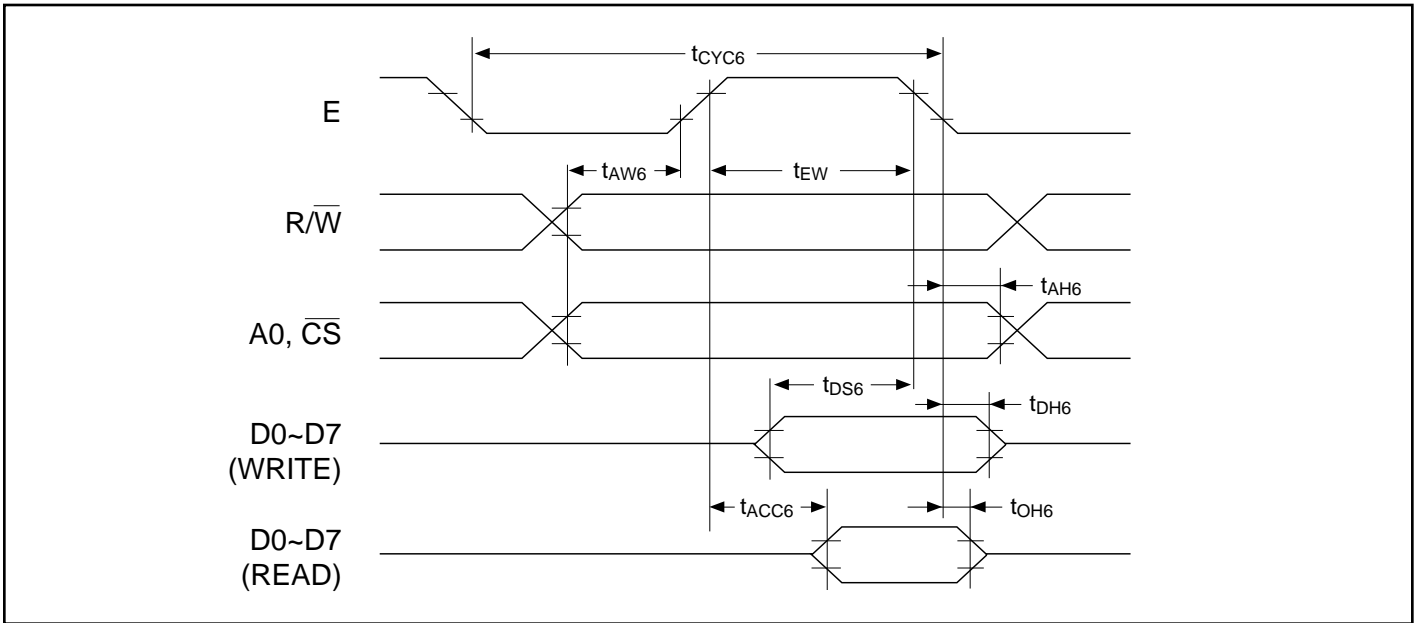

Figure 33. System bus READ/WRITE timing II (6800)

4.4.2.1 SED1330F

Ta = -20 to 75°C

Signal	Symbol	Parameter	Rating		Unit	Condition
			min	max		
A0, $\overline{CS}$ R/W	tAH6	Address hold time	10	—	ns	CL=100pF+1TTL pF
	tAW6	Address setup time	30	—	ns	
	tCYC6	System cycle time	(1)	—	ns	
D0 to D7	tDS6	Data setup time	120	—	ns	
	tDH6	Data hold time	10	—	ns	
	tACC6	Access time	—	120	ns	
	tOH6	Output disable time	10	50	ns	
E	tEW	Enable pulse width	220	—	ns	

**Note:** (1)  $t_{CYC6} = 2t_C + t_{EW} + t_{CEA} + 75 > t_{ACV} + 245$ :  
 memory control/movement control commands:  
 $= 4t_C + t_{EW} + 30$ :  
 all other commands:

1.  $t_{CYC6}$  means a cycle of ( $\overline{CS}.E$ ) not E alone.

## 4.4 SED1330 Timing Diagrams

### 4.4.3 Display memory READ timing

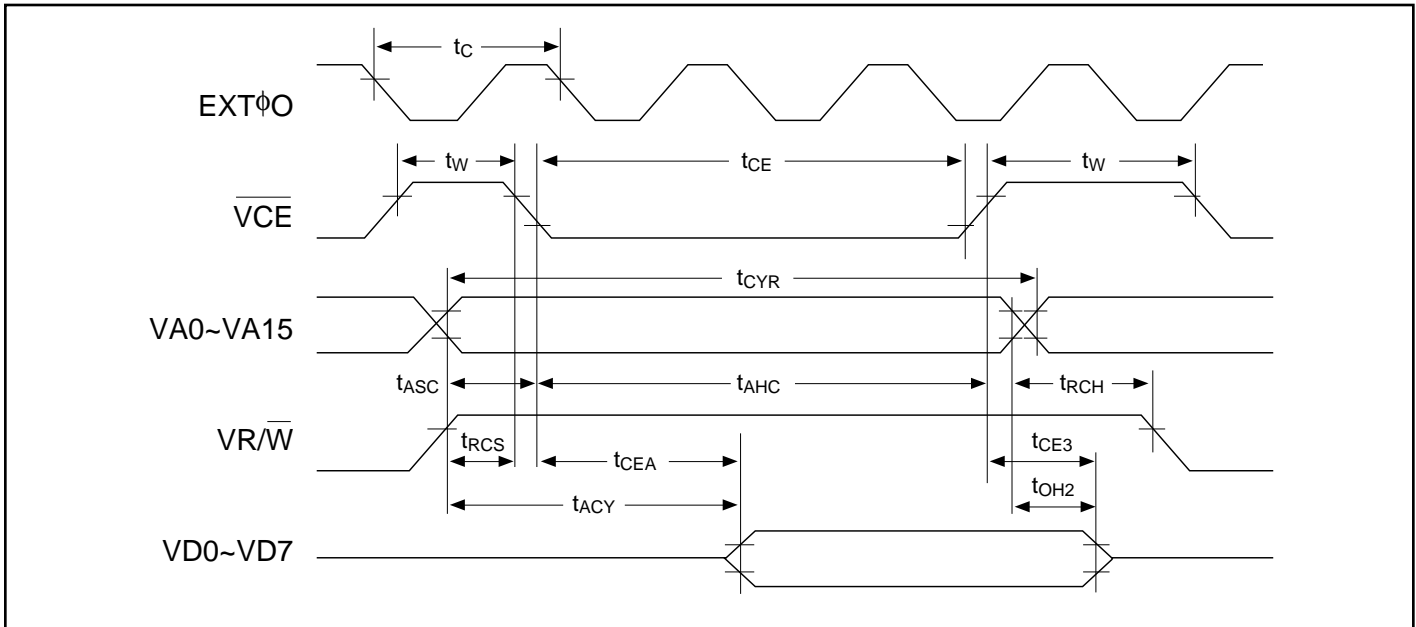

Figure 34. Display memory READ timing

#### 4.4.3.1 SED1330F

Ta = -20 to 75°C

Signal	Symbol	Parameter	Rating		Unit	Condition
			min	max		
EXT φ0	t <sub>c</sub>	Clock cycle	100	—	ns	CL = 100pF +1TTL
VCE	t <sub>w</sub>	VCE high level pulse width	t <sub>c</sub> -40	—	ns	
	t <sub>CE</sub>	VCE low level pulse width	2t <sub>c</sub> -40	—	ns	
VA0 to VA15	t <sub>CYR</sub>	Read cycle time	(1)	—	ns	
	t <sub>ASC</sub>	VCE address setup time (fall)	t <sub>c</sub> -45	—	ns	
	t <sub>AHC</sub>	VCE address hold time (fall)	2t <sub>c</sub> -40	—	ns	
VR/W	t <sub>RCS</sub>	VCE read cycle setup time (fall)	t <sub>c</sub> -45	—	ns	
	t <sub>RCH</sub>	VCE read cycle hold time (fall)	t <sub>c</sub> /2-35	—	ns	
VD0 to VD7	t <sub>ACV</sub>	Address access time	—	(2)	ns	
	t <sub>CEA</sub>	VCE access time	—	(3)	ns	
	t <sub>OH2</sub>	Output data hold time	0	—	ns	
	t <sub>CE2</sub>	VCE data off time	0	—	ns	

- Note:**
1. t<sub>CYR</sub> = 3t<sub>c</sub>
  2. t<sub>ACV</sub> = 3t<sub>c</sub> - 120
  3. t<sub>CEA</sub> = 2t<sub>c</sub> - 120



4.4 SED1330 Timing Diagrams

4.4.4 Display memory WRITE timing

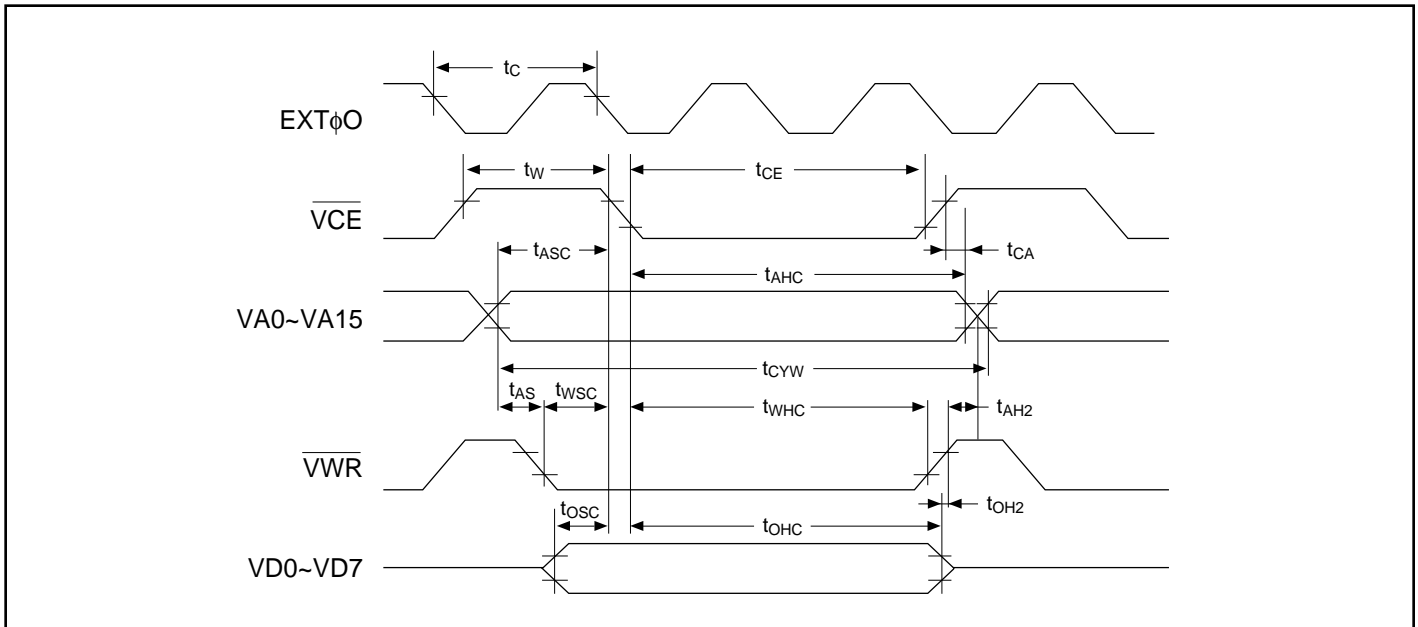

Figure 35. Display memory WRITE timing

4.4.4.1 SED1330F

Ta = -20 to 75°C

Signal	Symbol	Parameter	Rating		Unit	Condition
			min	max		
EXT φ0	tc	Clock cycle	100	—	ns	CL = 100pF +1TTL
VCE	tw	VCE high level pulse width	tc-40	—	ns	
	tCE	VCE low level pulse width	2tc-40	—	ns	
VA0 to VA15	tCYW	Write cycle time	3tc	—	ns	
	tAHC	VCE address hold time (fall)	2tc-40	—	ns	
	tASC	VCE address setup time (fall)	tc-55	—	ns	
	tCA	VCE address hold time (rise)	5	—	ns	
	tAS	VR/W address setup time (fall)	0	—	ns	
VR/W	tAH2	VR/W address hold time (rise)	15	—	ns	
	tWSC	VCE write setup time (fall)	tc-55	—	ns	
VD0 to VD7	tWHC	VCE write hold time (fall)	tc2-40	—	ns	
	tDSC	VCE data input setup time (fall)	twsc-10	—	ns	
	tDHC	VCE data input hold time (fall)	2tc-30	—	ns	
	tDH2	VR/W data hold time (rise)	10*	50	ns	

\* Lines VD0 to VD7 are latched.

4.4 SED1330 Timing Diagrams

4.4.5 LCD control timing

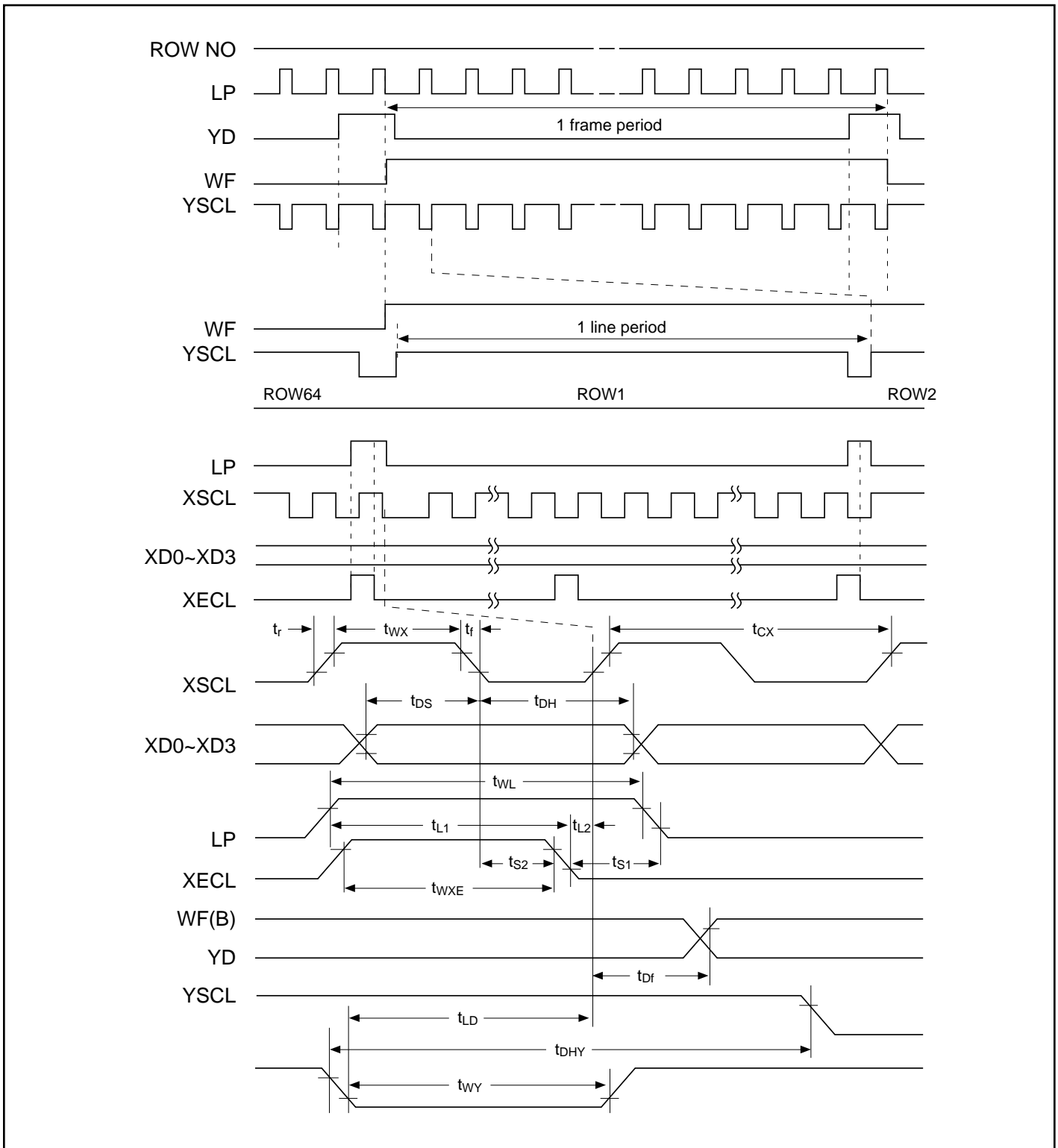

Figure 36. LCD control timing

## 4.4 SED1330 Timing Diagrams

## 4.4.5.1 SED1330F

T<sub>a</sub> = -20 to 75°C

Signal	Symbol	Parameter	Rating		Unit	Condition
			min	max		
EXT $\emptyset$ 0	t <sub>c</sub>	Clock cycle	100	—	ns	V <sub>DD</sub> = 5.0V ±10% CL=150F
	t <sub>r</sub>	$\overline{VCE}$ high level pulse width	—	35	ns	
	t <sub>f</sub>	$\overline{VCE}$ low level pulse width	—	35	ns	
XSCL	t <sub>CX</sub>	Shift clock cycle time	4t <sub>c</sub>	—	ns	
	t <sub>WX</sub>	XSCL clock pulse width	t <sub>CX2-80</sub>	—	ns	
XD0 to XD3	t <sub>DH</sub>	X-data hold time	t <sub>CX2-100</sub>	—	ns	
	t <sub>DS</sub>	X-data setup time	t <sub>CX2-100</sub>	—	ns	
LP	t <sub>LS</sub>	Latch data setup time	t <sub>CX2-100</sub>	—	ns	
	t <sub>WL</sub>	LP signal pulse width	t <sub>CX4-80</sub>	—	ns	
XECL	t <sub>L1</sub>	XECL setup time	t <sub>CX3-100</sub>	—	ns	
	t <sub>L2</sub>	XECL data hold time	t <sub>C-30</sub>	—	ns	
	t <sub>S1</sub>	Enable setup time	t <sub>C-30</sub>	—	ns	
	t <sub>S1</sub>	Enable delay time	t <sub>C-30</sub>	—	ns	
	t <sub>WXE</sub>	XECL clock pulse width	t <sub>CX3-80</sub>	—	ns	
WF	t <sub>DF</sub>	Time allowance of WF delay	—	100	ns	
YSCL	t <sub>LD</sub>	LP delay time against YSCL	t <sub>CX4-100</sub>	—	ns	
	t <sub>WY</sub>	YSCL clock pulse width	t <sub>CX4-80</sub>	—	ns	
YD	t <sub>DHY</sub>	Y-data hold time	t <sub>CX6-100</sub>	—	ns	

4.4 SED1330 Timing Diagrams

4.4.6 Oscillator timing

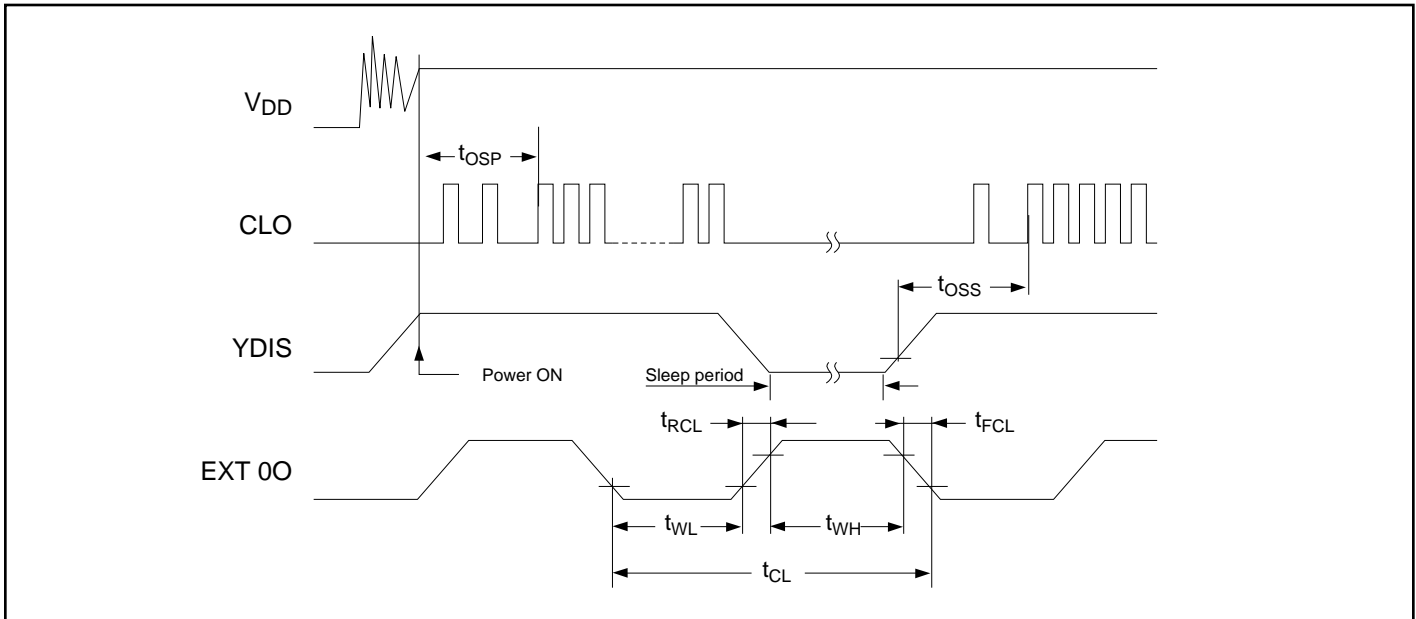

Figure 37. Oscillator timing

4.4.6.1 SED1330F

Ta = -20 to 75°C

Signal	Symbol	Parameter	Rating		Unit	Condition
			min	max		
CLO	tOSP	Time to stable CLO output after power ON	—	3	ms	RES = H 20 pF
	tOSS	Time to stable CLO output after sleep OFF	—	1	ms	
EXT00	tRCL	External clock rise time	—	15	ns	
	tFCL	External clock fall time	—	15	ns	
	tWH	External clock high-pulse width	Note 1	Note 2	ns	
	tWL	External clock low-pulse width	Note 1	Note 2	ns	
	tCL	External clock cycle	100	—	ns	

1.  $(t_C - t_{RCL} - t_{FCL}) \times 475/1000 < t_{WH}, t_{WL}$
2.  $(t_C - t_{RCL} - t_{FCL}) \times 525/1000 > t_{WH}, t_{WL}$

## 4.4 SED1330 Timing Diagrams

## 4.4.7 Measurement circuit

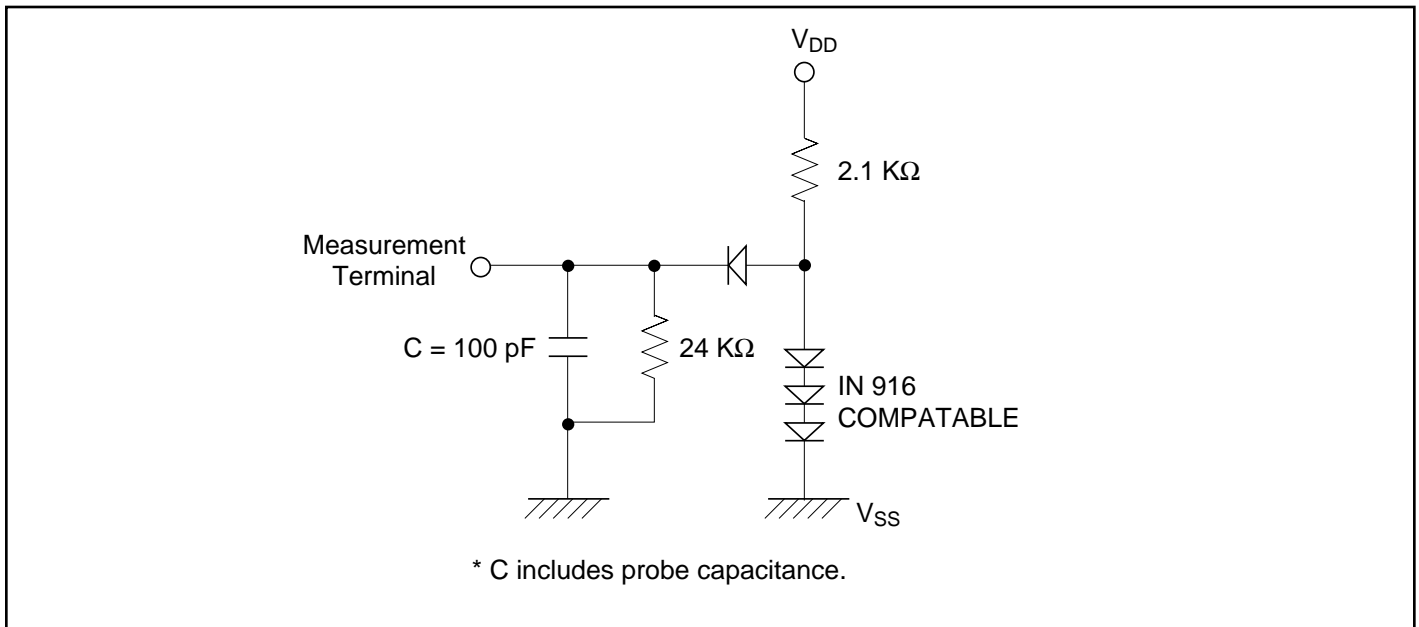

Figure 38. Measurement circuit

4.5 SED1335/SED1336 AC Timing Diagrams

4.5.1 8080 family Interface Timing

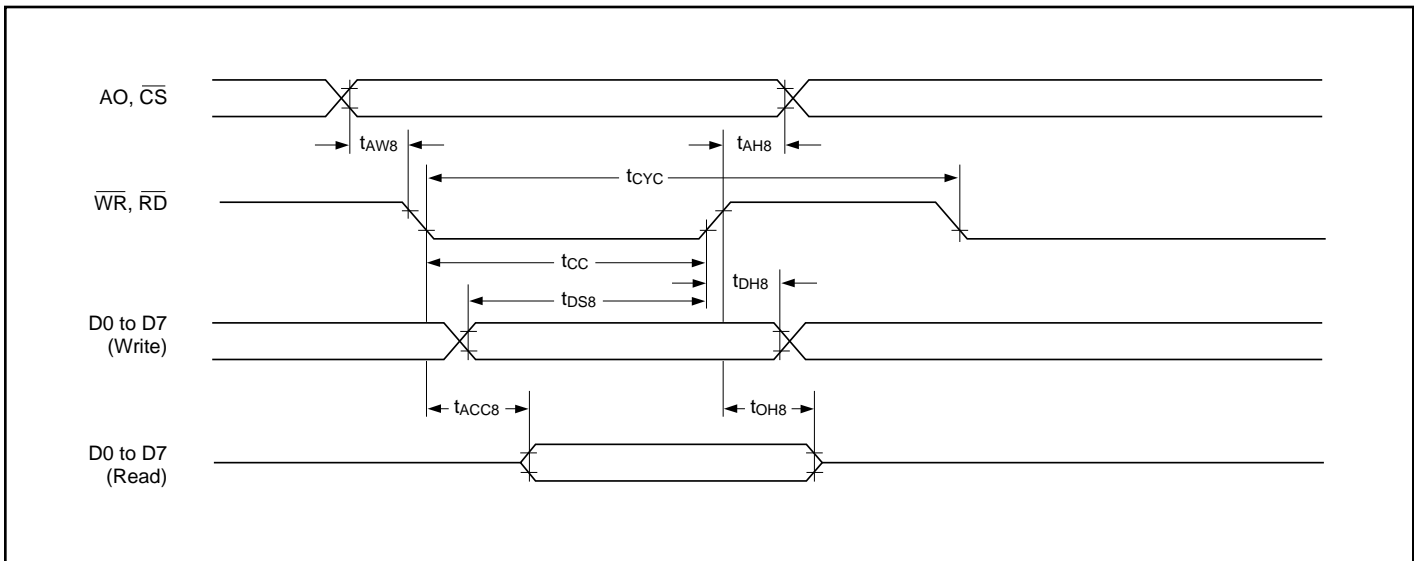

Figure 39. 8080 family interface timing

4.5.1.1 SED1335F

$T_a = -20$  to  $75^\circ\text{C}$

Signal	Symbol	Parameter	VDD = 4.5 to 5.5V		VDD = 2.7 to 4.5V		Unit	Condition
			min	max	min	max		
A0, $\overline{\text{CS}}$	$t_{AH8}$	Address hold time	10	—	10	—	ns	CL = 100 pF
	$t_{AW8}$	Address setup time	0	—	0	—	ns	
$\overline{\text{WR}}, \overline{\text{RD}}$	$t_{CYC}$	System cycle time	See note	—	See note	—	ns	
	$t_{CC}$	Strobe pulsewidth	120	—	150	—	ns	
D0 to D7	$t_{DS8}$	Data setup time	120	—	120	—	ns	
	$t_{DH8}$	Data hold time	5	—	5	—	ns	
	$t_{ACC8}$	$\overline{\text{RD}}$ access time	—	50	—	80	ns	
	$t_{OH8}$	Output disable time	10	50	10	55	ns	

**Note:** For memory control and system control commands:

$$t_{CYC8} = 2t_c + t_{CC} + t_{CEA} + 75 > t_{ACV} + 245$$

For all other commands:

$$t_{CYC8} = 4t_c + t_{CC} + 30$$

## 4.5.1.2 SED1336F

T<sub>a</sub> = -20 to 75°C

Signal	Symbol	Parameter	VDD = 4.5 to 5.5V		VDD = 3.0 to 4.5V		Unit	Condition
			min	max	min	max		
A0, $\overline{CS}$	tAH8	Address hold time	10	—	10	—	ns	CL = 100 pF
	tAW8	Address setup time	0	—	0	—	ns	
$\overline{WR}$ , $\overline{RD}$	tCYC	System cycle time	See note	—	See note	—	ns	
	tCC	Strobe pulsewidth	120	—	140	—	ns	
D0 to D7	tDS8	Data setup time	120	—	120	—	ns	
	tDH8	Data hold time	5	—	5	—	ns	
	tACC8	$\overline{RD}$ access time	—	50	—	70	ns	
	tOH8	Output disable time	10	50	10	50	ns	

**Note:** For memory control and system control commands:

$$t_{CYC8} = 2t_C + t_{CC} + t_{CEA} + 75 > t_{ACV} + 245$$

For all other commands:

$$t_{CYC8} = 4t_C + t_{CC} + 30$$

## 4.5.2 6800 family Interface Timing

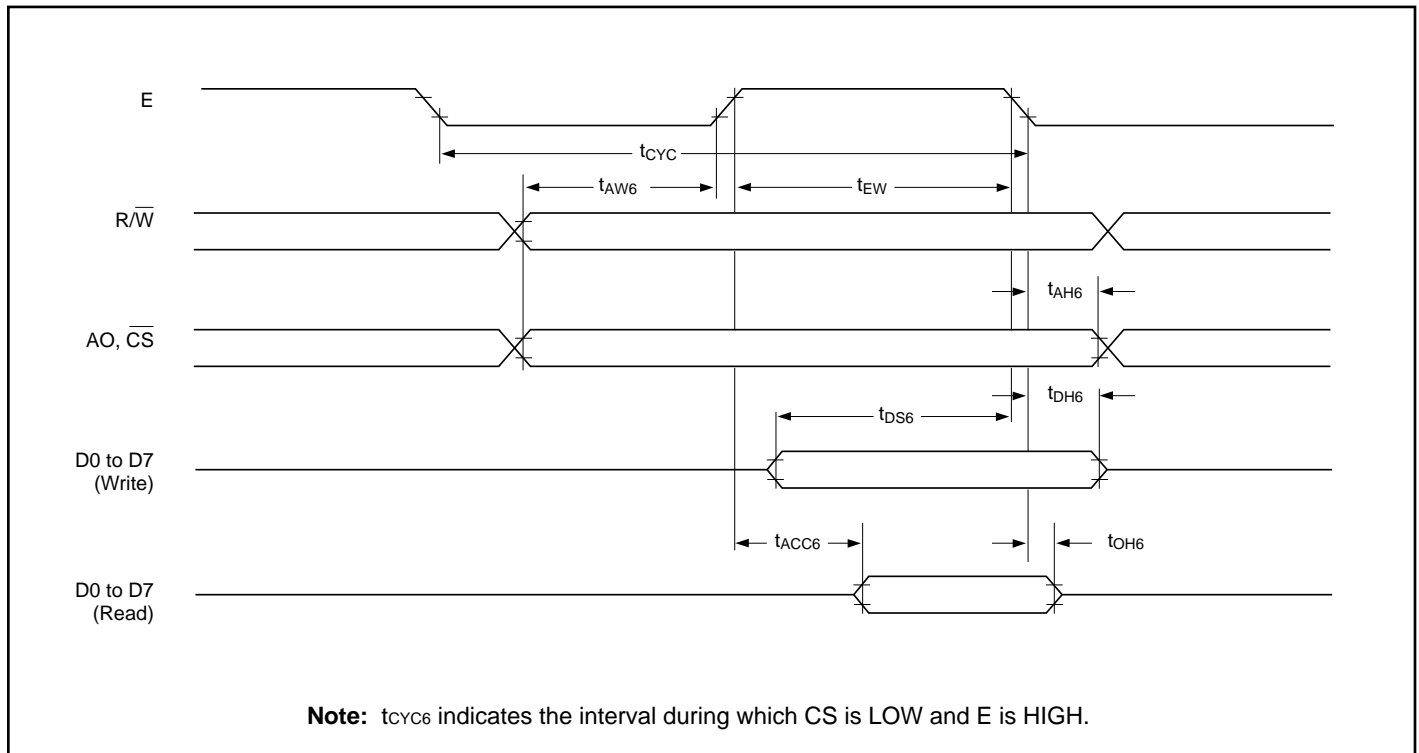

Figure 40. 6800 family interface timing



## 4.5.2.1 SED1335F

T<sub>a</sub> = –20 to 75°C

Signal	Symbol	Parameter	VDD = 4.5 to 5.5V		VDD = 2.7 to 4.5V		Unit	Condition
			min	max	min	max		
A0, $\overline{\text{CS}}$ , R/W	tCYC6	System cycle time	See note	—	See note	—	ns	CL = 100 pF
	tAW6	Address setup time	0	—	10	—	ns	
	tAH6	Address hold time	0	—	0	—	ns	
D0 to D7	tDS6	Data setup time	100	—	120	—	ns	
	tDH6	Data hold time	0	—	0	—	ns	
	tOH6	Output disable time	10	50	10	75	ns	
	tACC6	Access time	—	85	—	130	ns	
E	tEW	Enable pulsewidth	120	—	150	—	ns	

**Note:** For memory control and system control commands:

$$t_{\text{CYC6}} = 2t_{\text{C}} + t_{\text{EW}} + t_{\text{CEA}} + 75 > t_{\text{ACV}} + 245$$

For all other commands:

$$t_{\text{CYC6}} = 4t_{\text{C}} + t_{\text{EW}} + 30$$

## 4.5.2.2 SED1336F

T<sub>a</sub> = –20 to 75°C

Signal	Symbol	Parameter	VDD = 4.5 to 5.5V		VDD = 3.0 to 4.5V		Unit	Condition
			min	max	min	max		
A0, $\overline{\text{CS}}$ , R/W	tCYC6	System cycle time	See note	—	See note	—	ns	CL = 100 pF
	tAW6	Address setup time	0	—	10	—	ns	
	tAH6	Address hold time	0	—	0	—	ns	
D0 to D7	tDS6	Data setup time	100	—	120	—	ns	
	tDH6	Data hold time	0	—	0	—	ns	
	tOH6	Output disable time	10	50	10	70	ns	
	tACC6	Access time	—	85	—	120	ns	
E	tEW	Enable pulsewidth	120	—	140	—	ns	

**Note:** For memory control and system control commands:

$$t_{\text{CYC6}} = 2t_{\text{C}} + t_{\text{EW}} + t_{\text{CEA}} + 75 > t_{\text{ACV}} + 245$$

For all other commands:

$$t_{\text{CYC6}} = 4t_{\text{C}} + t_{\text{EW}} + 30$$

4.5.3 Display Memory Read Timing

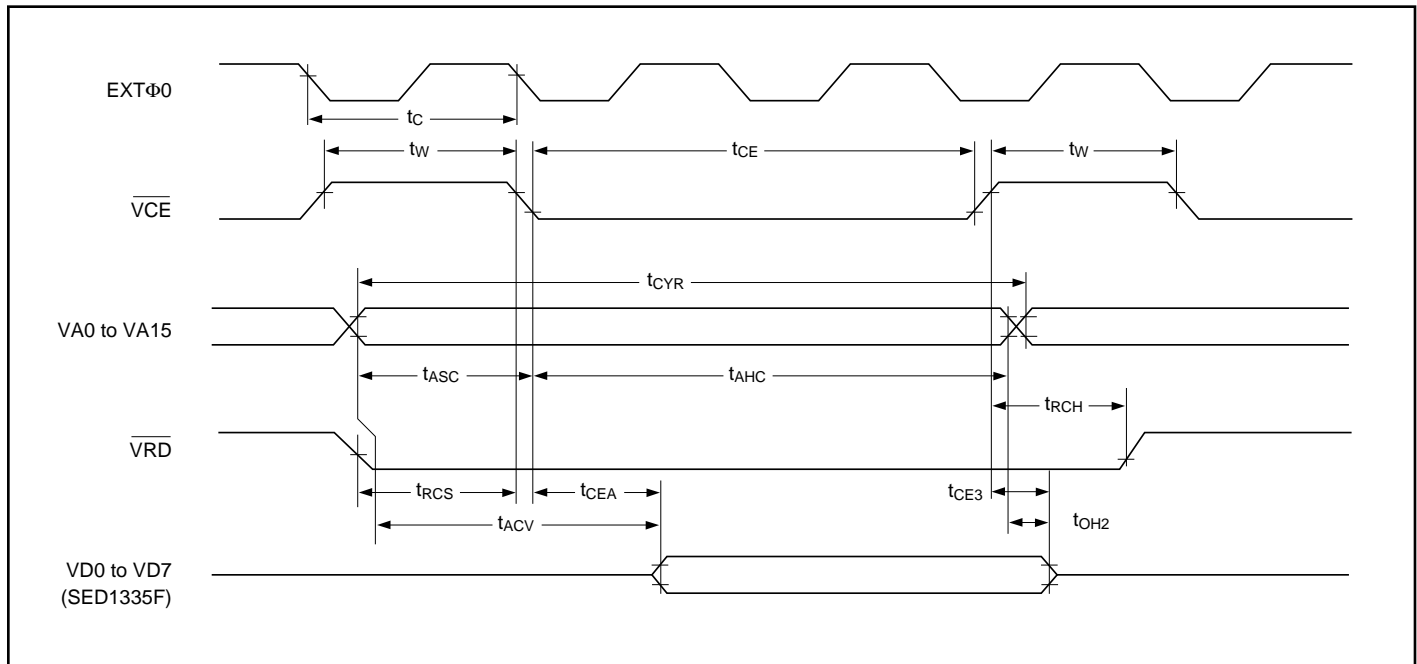

Figure 41. Display memory read timing

4.5.3.1 SED1335F

Ta = -20 to 75°C

Signal	Symbol	Parameter	VDD = 4.5 to 5.5V		VDD = 2.7 to 4.5V		Unit	Condition
			min	max	min	max		
EXT φ0	tc	Clock period	100	—	125	—	ns	CL = 100 pF
VCE	tw	VCE HIGH-level pulse-width	tc - 50	—	tc - 50	—	ns	
	tCE	VCE LOW-level pulse-width	2tc - 30	—	2tc - 30	—	ns	
VA0 to VA15	tCYR	Read cycle time	3tc	—	3tc	—	ns	
	tASC	Address setup time to falling edge of VCE	tc - 70	—	tc - 100	—	ns	
	tAHC	Address hold time from falling edge of VCE	2tc - 30	—	2tc - 40	—	ns	
VRD	tRCS	Read cycle setup time to falling edge of VCE	tc - 45	—	tc - 60	—	ns	
	tRCH	Read cycle hold time from rising edge of VCE	0.5tc	—	0.5tc	—	ns	
VD0 to VD7	tACV	Address access time	—	3tc - 100	—	3tc - 115	ns	
	tCEA	VCE access time	—	2tc - 80	—	2tc - 90	ns	
	tOH2	Output data hold time	0	—	0	—	ns	
	tCE3	VCE to data off time	0	—	0	—	ns	

## 4.5.3.2 SED1336F

T<sub>a</sub> = -20 to 75°C

Signal	Symbol	Parameter	VDD = 4.5 to 5.5V		VDD = 3.0 to 4.5V		Unit	Condition
			min	max	min	max		
EXT $\phi$ 0	t <sub>C</sub>	Clock period	100	—	125	—	ns	CL = 100 pF
$\overline{\text{VCE}}$	t <sub>W</sub>	$\overline{\text{VCE}}$ HIGH-level pulse-width	t <sub>C</sub> - 50	—	t <sub>C</sub> - 50	—	ns	
	t <sub>CE</sub>	$\overline{\text{VCE}}$ LOW-level pulse-width	2t <sub>C</sub> - 30	—	2t <sub>C</sub> - 30	—	ns	
VA0 to VA15	t <sub>CYR</sub>	Read cycle time	3t <sub>C</sub>	—	3t <sub>C</sub>	—	ns	
	t <sub>ASC</sub>	Address setup time to falling edge of $\overline{\text{VCE}}$	t <sub>C</sub> - 70	—	t <sub>C</sub> - 100	—	ns	
	t <sub>AHC</sub>	Address hold time from falling edge of $\overline{\text{VCE}}$	2t <sub>C</sub> - 30	—	2t <sub>C</sub> - 40	—	ns	
$\overline{\text{VRD}}$	t <sub>RCS</sub>	Read cycle setup time to falling edge of $\overline{\text{VCE}}$	t <sub>C</sub> - 45	—	t <sub>C</sub> - 55	—	ns	
	t <sub>RCH</sub>	Read cycle hold time from rising edge of $\overline{\text{VCE}}$	0.5t <sub>C</sub>	—	0.5t <sub>C</sub>	—	ns	
VD0 to VD7	t <sub>ACV</sub>	Address access time	—	3t <sub>C</sub> - 100	—	3t <sub>C</sub> - 110	ns	
	t <sub>CEA</sub>	$\overline{\text{VCE}}$ access time	—	2t <sub>C</sub> - 80	—	2t <sub>C</sub> - 85	ns	
	t <sub>OH2</sub>	Output data hold time	0	—	0	—	ns	
	t <sub>CE3</sub>	$\overline{\text{VCE}}$ to data off time	0	—	0	—	ns	

4.5.4 Display Memory Write Timing

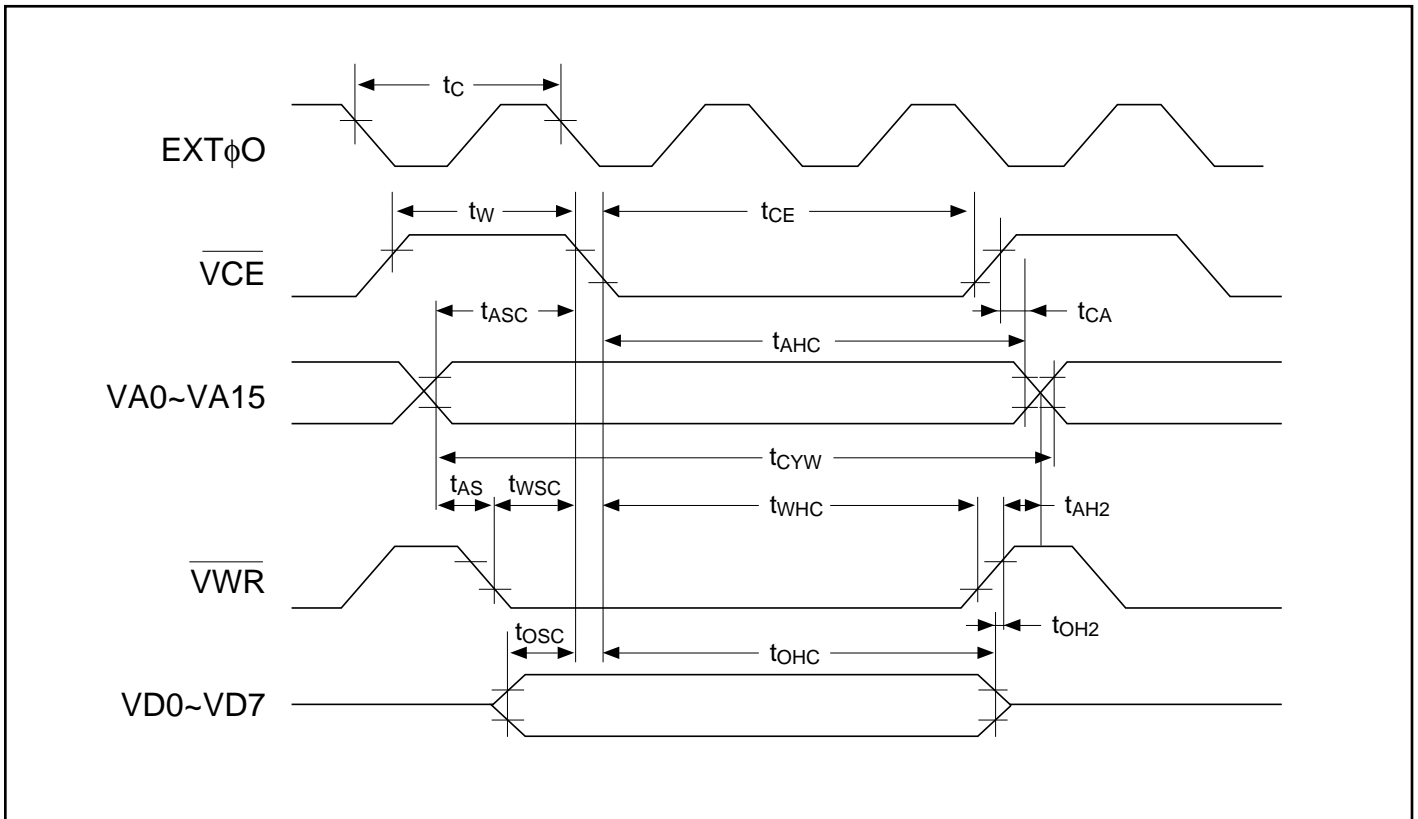

Figure 42. Display memory write timing

## 4.5.4.1 SED1335F

T<sub>a</sub> = -20 to 75°C

Signal	Symbol	Parameter	VDD = 4.5 to 5.5V		VDD = 2.7 to 4.5V		Unit	Condition
			min	max	min	max		
EXT $\phi$ 0	t <sub>C</sub>	Clock period	100	—	125	—	ns	CL = 100 pF
$\overline{VCE}$	t <sub>W</sub>	$\overline{VCE}$ HIGH-level pulse-width	t <sub>C</sub> - 50	—	t <sub>C</sub> - 50	—	ns	
	t <sub>CE</sub>	$\overline{VCE}$ LOW-level pulse-width	2t <sub>C</sub> - 30	—	2t <sub>C</sub> - 30	—	ns	
VA0 to VA15	t <sub>CYW</sub>	Write cycle time	3t <sub>C</sub>	—	3t <sub>C</sub>	—	ns	
	t <sub>AHC</sub>	Address hold time from falling edge of $\overline{VCE}$	2t <sub>C</sub> - 30	—	2t <sub>C</sub> - 40	—	ns	
	t <sub>ASC</sub>	Address setup time to falling edge of $\overline{VCE}$	t <sub>C</sub> - 70	—	t <sub>C</sub> - 110	—	ns	
	t <sub>CA</sub>	Address hold time from rising edge of $\overline{VCE}$	0	—	0	—	ns	
	t <sub>AS</sub>	Address setup time to falling edge of $\overline{VWR}$	0	—	0	—	ns	
	t <sub>AH2</sub>	Address hold time from rising edge of $\overline{VWR}$	10	—	10	—	ns	
$\overline{VWR}$	t <sub>WSC</sub>	Write setup time to falling edge of $\overline{VCE}$	t <sub>C</sub> - 80	—	t <sub>C</sub> - 115	—	ns	
	t <sub>WHC</sub>	Write hold time from falling edge of $\overline{VCE}$	2t <sub>C</sub> - 20	—	2t <sub>C</sub> - 20	—	ns	
VD0 to VD7	t <sub>DSC</sub>	Data input setup time to falling edge of $\overline{VCE}$	t <sub>C</sub> - 85	—	t <sub>C</sub> - 125	—	ns	
	t <sub>DHC</sub>	Data input hold time from falling edge of $\overline{VCE}$	2t <sub>C</sub> - 30	—	2t <sub>C</sub> - 30	—	ns	
	t <sub>DH2</sub>	Data hold time from rising edge of $\overline{VWR}$	5	50	5	50	ns	

**Note:** VD0 to VD7 are latching input/outputs. While the bus is high impedance, VD0 to VD7 retain the write data until the data read from the memory is placed on the bus.

## 4.5.4.2 SED1336F

T<sub>a</sub> = -20 to 75°C

Signal	Symbol	Parameter	VDD = 4.5 to 5.5V		VDD = 3.0 to 4.5V		Unit	Condition
			min	max	min	max		
EXT $\phi$ 0	t <sub>c</sub>	Clock period	100	—	125	—	ns	CL = 100 pF
$\overline{VCE}$	t <sub>w</sub>	$\overline{VCE}$ HIGH-level pulse-width	t <sub>c</sub> - 50	—	t <sub>c</sub> - 50	—	ns	
	t <sub>CE</sub>	$\overline{VCE}$ LOW-level pulse-width	2t <sub>c</sub> - 30	—	2t <sub>c</sub> - 30	—	ns	
VA0 to VA15	t <sub>CYW</sub>	Write cycle time	3t <sub>c</sub>	—	3t <sub>c</sub>	—	ns	
	t <sub>AHC</sub>	Address hold time from falling edge of $\overline{VCE}$	2t <sub>c</sub> - 30	—	2t <sub>c</sub> - 40	—	ns	
	t <sub>ASC</sub>	Address setup time to falling edge of $\overline{VCE}$	t <sub>c</sub> - 70	—	t <sub>c</sub> - 100	—	ns	
	t <sub>CA</sub>	Address hold time from rising edge of $\overline{VCE}$	0	—	0	—	ns	
	t <sub>AS</sub>	Address setup time to falling edge of $\overline{VWR}$	0	—	0	—	ns	
	t <sub>AH2</sub>	Address hold time from rising edge of $\overline{VWR}$	10	—	10	—	ns	
$\overline{VWR}$	t <sub>WSC</sub>	Write setup time to falling edge of $\overline{VCE}$	t <sub>c</sub> - 80	—	t <sub>c</sub> - 110	—	ns	
	t <sub>WHC</sub>	Write hold time from falling edge of $\overline{VCE}$	2t <sub>c</sub> - 20	—	2t <sub>c</sub> - 20	—	ns	
VD0 to VD7	t <sub>DSC</sub>	Data input setup time to falling edge of $\overline{VCE}$	t <sub>c</sub> - 85	—	t <sub>c</sub> - 120	—	ns	
	t <sub>DHC</sub>	Data input hold time from falling edge of $\overline{VCE}$	2t <sub>c</sub> - 30	—	2t <sub>c</sub> - 30	—	ns	
	t <sub>DH2</sub>	Data hold time from rising edge of $\overline{VWR}$	5	50	5	50	ns	

**Note:** VD0 to VD7 are latching input/outputs. While the bus is high impedance, VD0 to VD7 retain the write data until the data read from the memory is placed on the bus.

4.5.5 SLEEP IN Command Timing

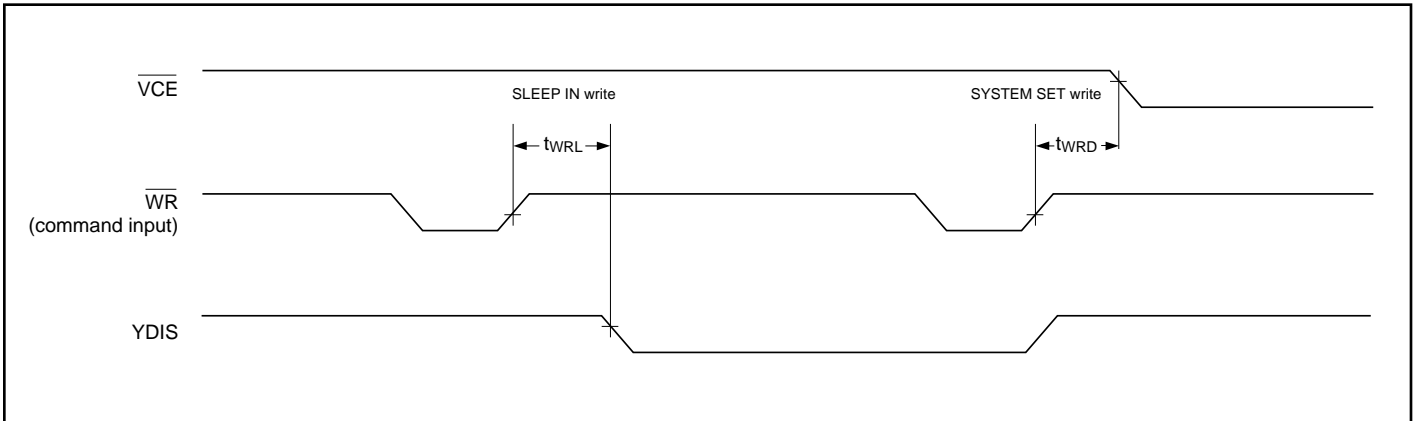

Figure 43. SLEEP IN command timing

4.5.5.1 SED1335F

Ta = -20 to 75°C

Signal	Symbol	Parameter	VDD = 4.5 to 5.5V		VDD = 2.7 to 4.5V		Unit	Condition
			min	max	min	max		
$\overline{WR}$	tWRD	$\overline{VCE}$ falling-edge delay time	See note 1	—	See note 1	—	ns	CL = 100 pF
	tWRL	YDIS falling-edge delay time	—	See note 2	—	See note 2	ns	

Notes:

1.  $t_{WRD} = 18t_C + t_{OSS} + 40$  ( $t_{OSS}$  is the time delay from the sleep state until stable operation)
2.  $t_{WRL} = 36t_C \times [TC/R] \times [L/F] + 70$

4.5.5.2 SED1336F

Ta = -20 to 75°C

Signal	Symbol	Parameter	VDD = 4.5 to 5.5V		VDD = 3.0 to 4.5V		Unit	Condition
			min	max	min	max		
$\overline{WR}$	tWRD	$\overline{VCE}$ falling-edge delay time	See note 1	—	See note 1	—	ns	CL = 100 pF
	tWRL	YDIS falling-edge delay time	—	See note 2	—	See note 2	ns	

Notes:

1.  $t_{WRD} = 18t_C + t_{OSS} + 40$  ( $t_{OSS}$  is the time delay from the sleep state until stable operation)
2.  $t_{WRL} = 36t_C \times [TC/R] \times [L/F] + 70$

4.5.6 External Oscillator Signal Timing

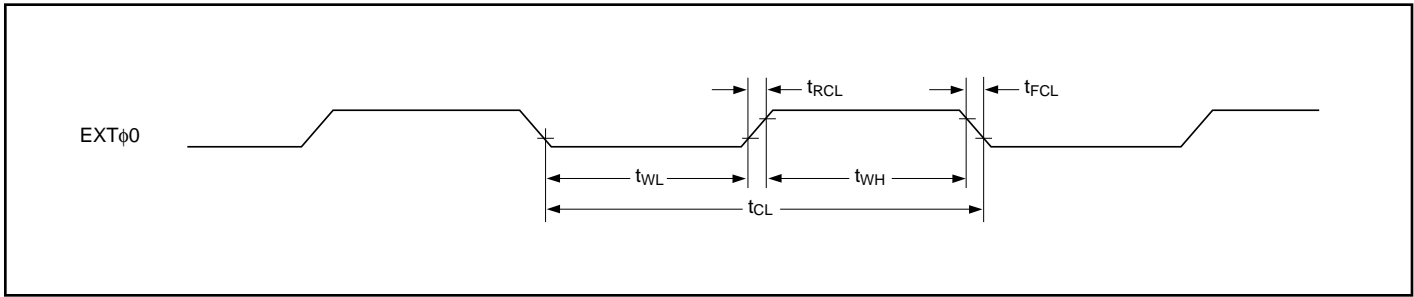

Figure 44. External oscillator signal timing

4.5.6.1 SED1335F

T<sub>a</sub> = -20 to 75°C

Signal	Symbol	Parameter	VDD = 4.5 to 5.5V		VDD = 2.7 to 4.5V		Unit	Condition
			min	max	min	max		
EXT φ0	t <sub>RCL</sub>	External clock rise time	—	15	—	15	ns	
	t <sub>FCL</sub>	External clock fall time	—	15	—	15	ns	
	t <sub>WH</sub>	External clock HIGH-level pulsewidth	See note 1	See note 2	See note 1	See note 2	ns	
	t <sub>WL</sub>	External clock LOW-level pulsewidth	See note 1	See note 2	See note 1	See note 2	ns	
	t <sub>C</sub>	External clock period	100	—	125	—	ns	

Notes:

- $(t_c - t_{RCL} - t_{FCL}) \times \frac{475}{1000} < t_{WH}, t_{WL}$
- $(t_c - t_{RCL} - t_{FCL}) \times \frac{525}{1000} > t_{WH}, t_{WL}$

4.5.6.2 SED1336F

T<sub>a</sub> = -20 to 75°C

Signal	Symbol	Parameter	VDD = 4.5 to 5.5V		VDD = 3.0 to 4.5V		Unit	Condition
			min	max	min	max		
EXT φ0	t <sub>RCL</sub>	External clock rise time	—	15	—	15	ns	
	t <sub>FCL</sub>	External clock fall time	—	15	—	15	ns	
	t <sub>WH</sub>	External clock HIGH-level pulsewidth	See note 1	See note 2	See note 1	See note 2	ns	
	t <sub>WL</sub>	External clock LOW-level pulsewidth	See note 1	See note 2	See note 1	See note 2	ns	
	t <sub>C</sub>	External clock period	100	—	125	—	ns	

Notes:

- $(t_c - t_{RCL} - t_{FCL}) \times \frac{475}{1000} < t_{WH}, t_{WL}$
- $(t_c - t_{RCL} - t_{FCL}) \times \frac{525}{1000} > t_{WH}, t_{WL}$



4.5.7 LCD Output Timing

The following characteristics are for a 1/64 duty cycle.

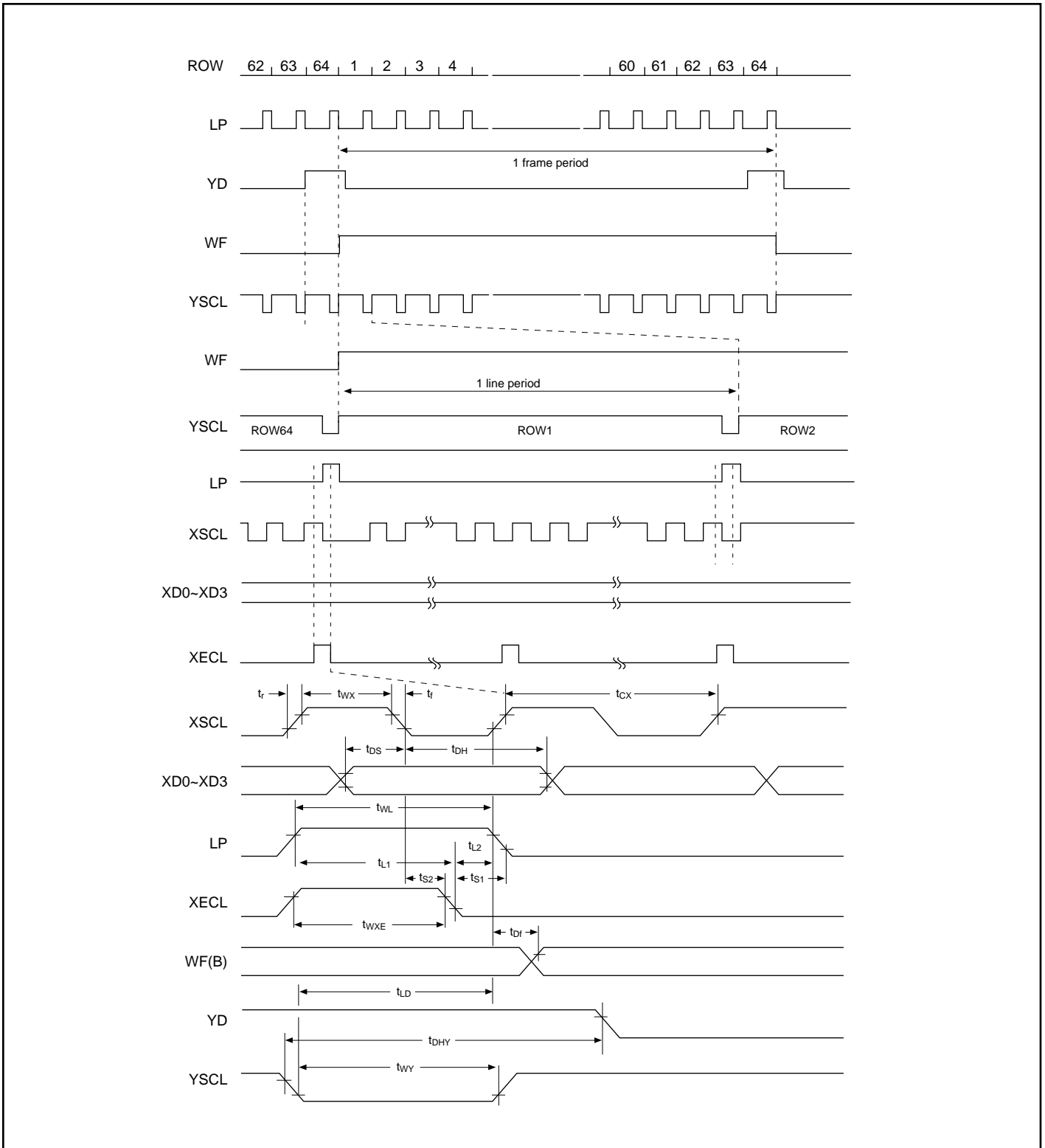

Figure 45. LCD output timing

## 4.5.7.1 SED1330F

Ta = -20 to 75°C

Signal	Symbol	Parameter	Rating		Unit	Condition
			min	max		
	tr	VCE high level pulse width	—	35	ns	VDD = 5.0V ±10% CL=150F
	tf	VCE low level pulse width	—	35	ns	
XSCL	tCX	Shift clock cycle time	4tc-70	—	ns	
	tWX	XSCL clock pulse width	2tc-80	—	ns	
XD0 to XD3	tDH	X-data hold time	2tc-100	—	ns	
	tDS	X-data setup time	2tc-100	—	ns	
LP	tLS	Latch data setup time	2tc-100	—	ns	
	tWL	LP signal pulse width	4tc-80	—	ns	
XECL	tL1	XECL setup time	3tc-100	—	ns	
	tL2	XECL data hold time	tc-30	—	ns	
	ts1	Enable setup time	tc-30	—	ns	
	ts1	Enable delay time	tc-30	—	ns	
	tWXE	XECL clock pulse width	3tc-80	—	ns	
WF	tDF	Time allowance of WF delay	—	100	ns	
YSCL	tLD	LP delay time against YSCL	4tc-100	—	ns	
	tWY	YSCL clock pulse width	4tc-80	—	ns	
YD	tDHY	Y-data hold time	6tc-100	—	ns	

### Notes:

1. The E-1330 reads display memory data from the address of the top left corner of the display screen, then scans horizontally until it reaches the address for the bottom right corner of the display screen. Therefore, each line of X-driver data is sent starting from the left side of the display line.
2. The E-1330 uses nine cycles of  $\emptyset 0$  as the basic cycle ( $t_c$ ). The XSCL waveform is shown in the following figure.

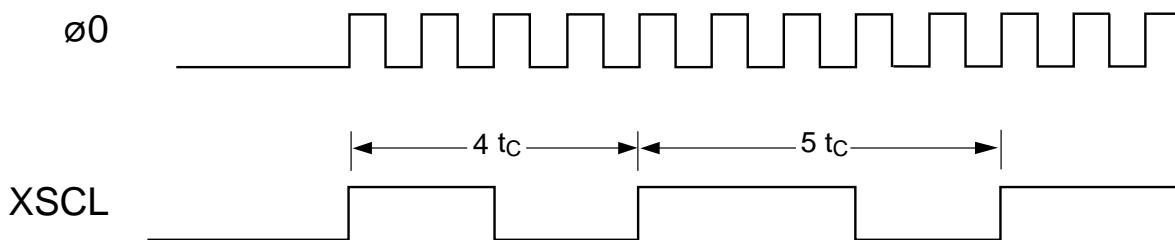

## 4.5.7.2 SED1335F

T<sub>a</sub> = –20 to 75°C

Signal	Symbol	Parameter	VDD = 4.5 to 5.5V		VDD = 2.7 to 4.5V		Unit	Condition
			min	max	min	max		
	t <sub>r</sub>	Rise time	—	30	—	40	ns	CL = 100 pF
	t <sub>f</sub>	Fall time	—	30	—	40	ns	
XSCL	t <sub>CX</sub>	Shift clock cycle time	4t <sub>c</sub>	—	4t <sub>c</sub>	—	ns	
	t <sub>WX</sub>	XSCL clock pulsewidth	2t <sub>c</sub> – 60	—	2t <sub>c</sub> – 60	—	ns	
XD0 to XD3	t <sub>DH</sub>	X data hold time	2t <sub>c</sub> – 50	—	2t <sub>c</sub> – 50	—	ns	
	t <sub>DS</sub>	X data setup time	2t <sub>c</sub> – 100	—	2t <sub>c</sub> – 105	—	ns	
LP	t <sub>LS</sub>	Latch data setup time	2t <sub>c</sub> – 50	—	2t <sub>c</sub> – 50	—	ns	
	t <sub>WL</sub>	LP pulsewidth	4t <sub>c</sub> – 80	—	4t <sub>c</sub> – 120	—	ns	
	t <sub>LD</sub>	LP delay time from XSCL	0	—	0	—	ns	
WF	t <sub>DF</sub>	Permitted WF delay	—	50	—	50	ns	
YD	t <sub>DHY</sub>	Y data hold time	2t <sub>c</sub> – 20	—	2t <sub>c</sub> – 20	—	ns	

## 4.5.7.3 SED1336F

T<sub>a</sub> = –20 to 75°C

Signal	Symbol	Parameter	VDD = 4.5 to 5.5V		VDD = 3.0 to 4.5V		Unit	Condition
			min	max	min	max		
	t <sub>r</sub>	Rise time	—	30	—	35	ns	CL = 100 pF
	t <sub>f</sub>	Fall time	—	30	—	35	ns	
XSCL	t <sub>CX</sub>	Shift clock cycle time	4t <sub>c</sub>	—	4t <sub>c</sub>	—	ns	
	t <sub>WX</sub>	XSCL clock pulsewidth	2t <sub>c</sub> – 60	—	2t <sub>c</sub> – 60	—	ns	
XD0 to XD3	t <sub>DH</sub>	X data hold time	2t <sub>c</sub> – 50	—	2t <sub>c</sub> – 50	—	ns	
	t <sub>DS</sub>	X data setup time	2t <sub>c</sub> – 100	—	2t <sub>c</sub> – 100	—	ns	
LP	t <sub>LS</sub>	Latch data setup time	2t <sub>c</sub> – 50	—	2t <sub>c</sub> – 50	—	ns	
	t <sub>WL</sub>	LP pulsewidth	4t <sub>c</sub> – 80	—	4t <sub>c</sub> – 100	—	ns	
	t <sub>LD</sub>	LP delay time from XSCL	0	—	0	—	ns	
WF	t <sub>DF</sub>	Permitted WF delay	—	50	—	50	ns	
YD	t <sub>DHY</sub>	Y data hold time	2t <sub>c</sub> – 20	—	2t <sub>c</sub> – 20	—	ns	

**Note:** The SED1335F/1336F reads display memory data from the address of the top left corner of the display screen, then scans horizontally until it reaches the address for the bottom right corner of the display screen. Therefore, each line of X-driver data is sent starting from the left side of the display line.

**THIS PAGE INTENTIONALLY BLANK**

# **5.0**

## ***Display Control Functions***

**THIS PAGE INTENTIONALLY BLANK**

5.0 Display Control Functions

5.1 Character Configuration

The origin of each character bitmap is in the top left corner as shown in Figure 38. Adjacent bits in each byte are horizontally adjacent in the corresponding character image.

Although the size of the bitmap is fixed by the character generator, the actual displayed size of the character field can be varied in both dimensions.

If the area outside the character bitmap contains only zeros, the displayed character size can easily be increased by increasing FX and FY, as the zeros ensure that the extra space between displayed characters is blank.

The displayed character width can be set to any value up to 16 even if each horizontal row of the bitmap is two bytes wide.

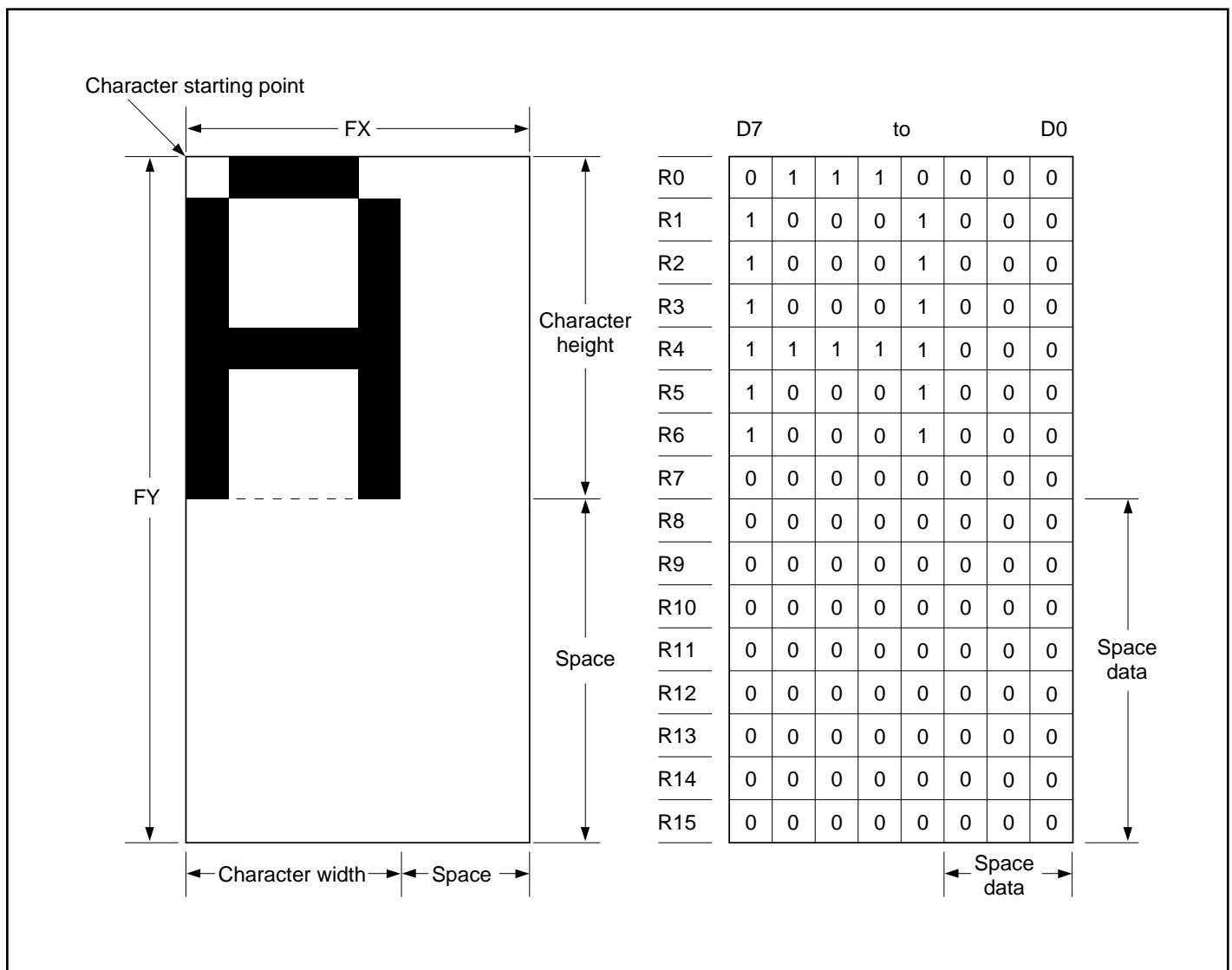
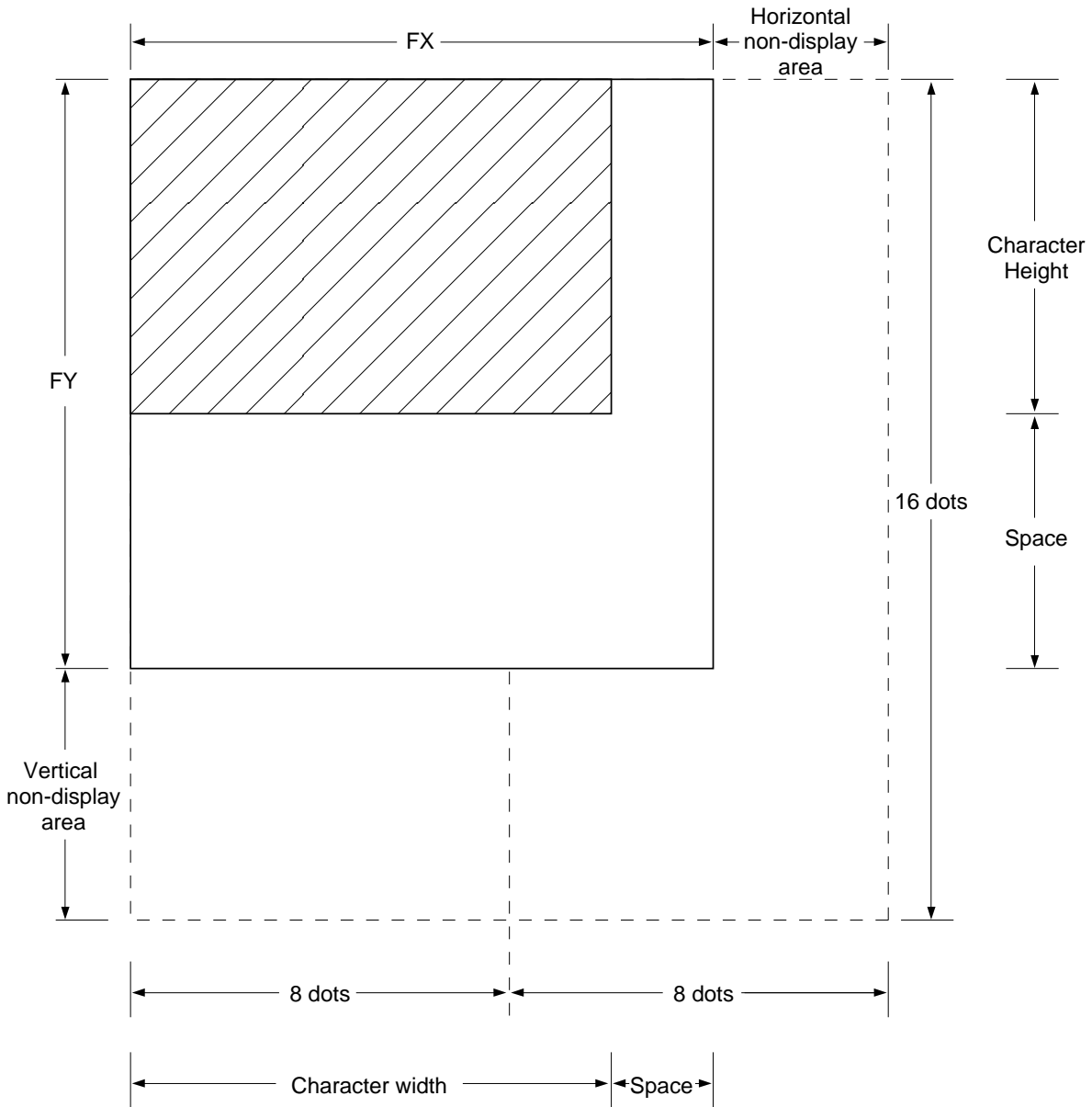

Figure 46. Example of character display ([FX] ≤ 8) and generator bitmap



**Note:** The SED1330F/1335F/1336F does not automatically insert spaces between characters. If the displayed character size is 8 pixels or less and the space between character origins is nine pixels or more, the bitmap must use two bytes per row, even though the character image requires only one.

Figure 47. Character width greater than one byte wide ([FX] = 9)



5.2 Screen Configuration

5.2.1 Screen Configuration

The basic screen configuration of the SED1330F/1335F/1336F is as a single text screen or as overlapping text and graphics screens. The graphics screen uses eight times as much display memory as the text screen.

Figure 40 shows the relationship between the virtual screens and the physical screen.

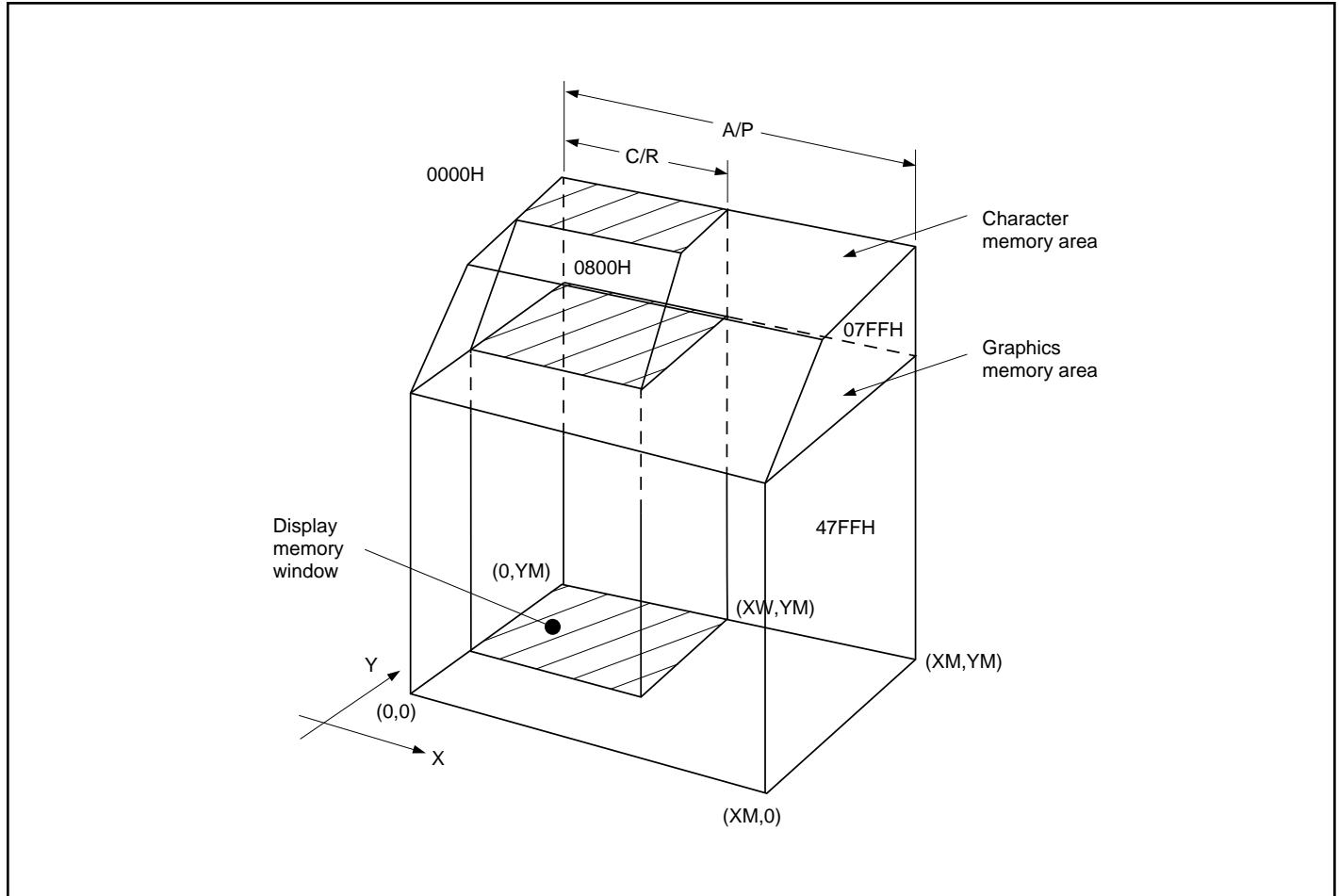

Figure 48. Virtual and physical screen relationship

5.2.2 Display Address Scanning

The SED1330F/1335F/1336F scans the display memory in the same way as a raster scan CRT screen. Each row is scanned from left to right until the address range equals C/R. Rows are scanned from top to bottom.

In graphics mode, at the start of each line, the address counter is set to the address at the start of the previous line plus the address pitch, AP.

In text mode, the address counter is set to the same start address, and the same character data is read, for each row in the character bitmap. However, a new row of the character generator output is used each time. Once all the rows in the character bitmap have been displayed, the address counter is set to the start address plus AP and the next line of text is displayed.

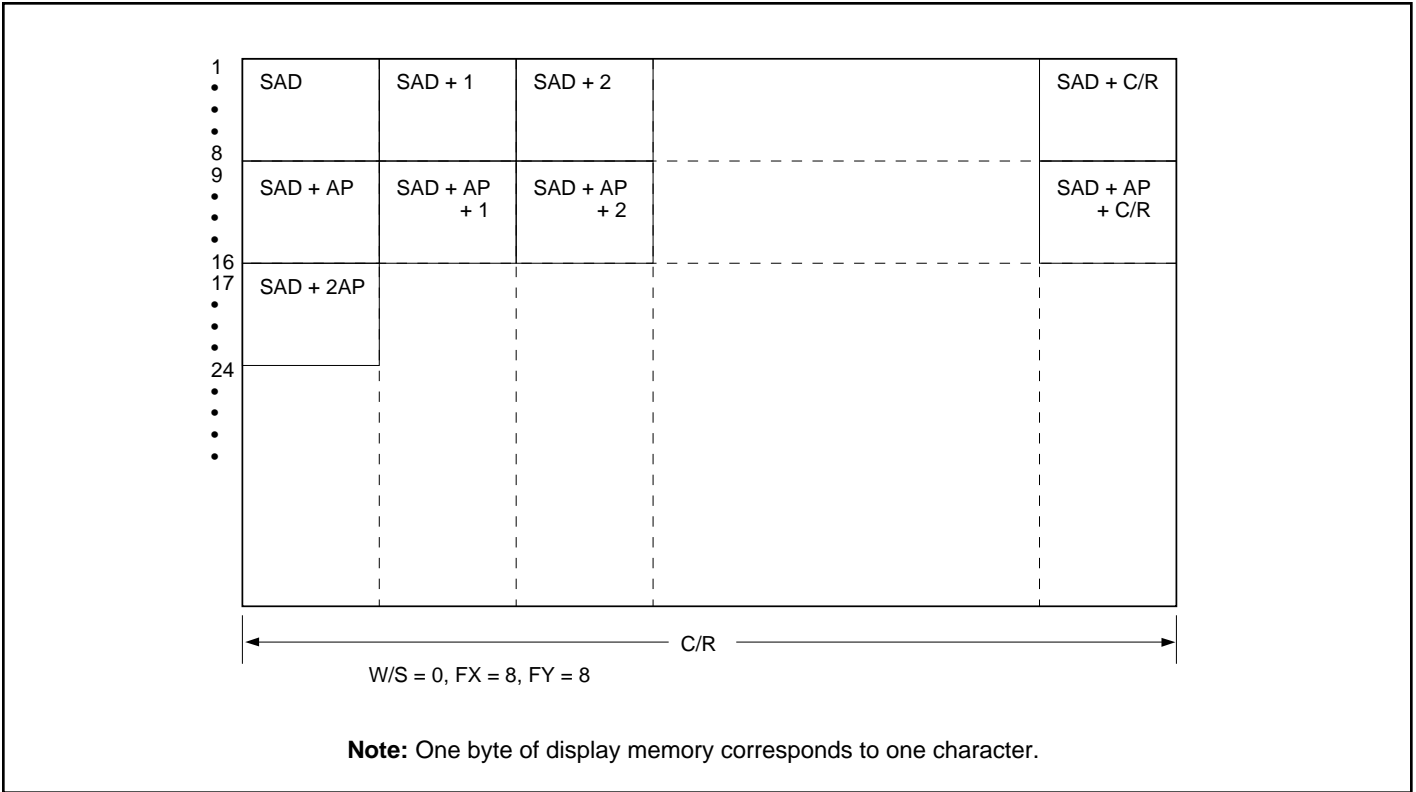

Figure 49. Character position parameters

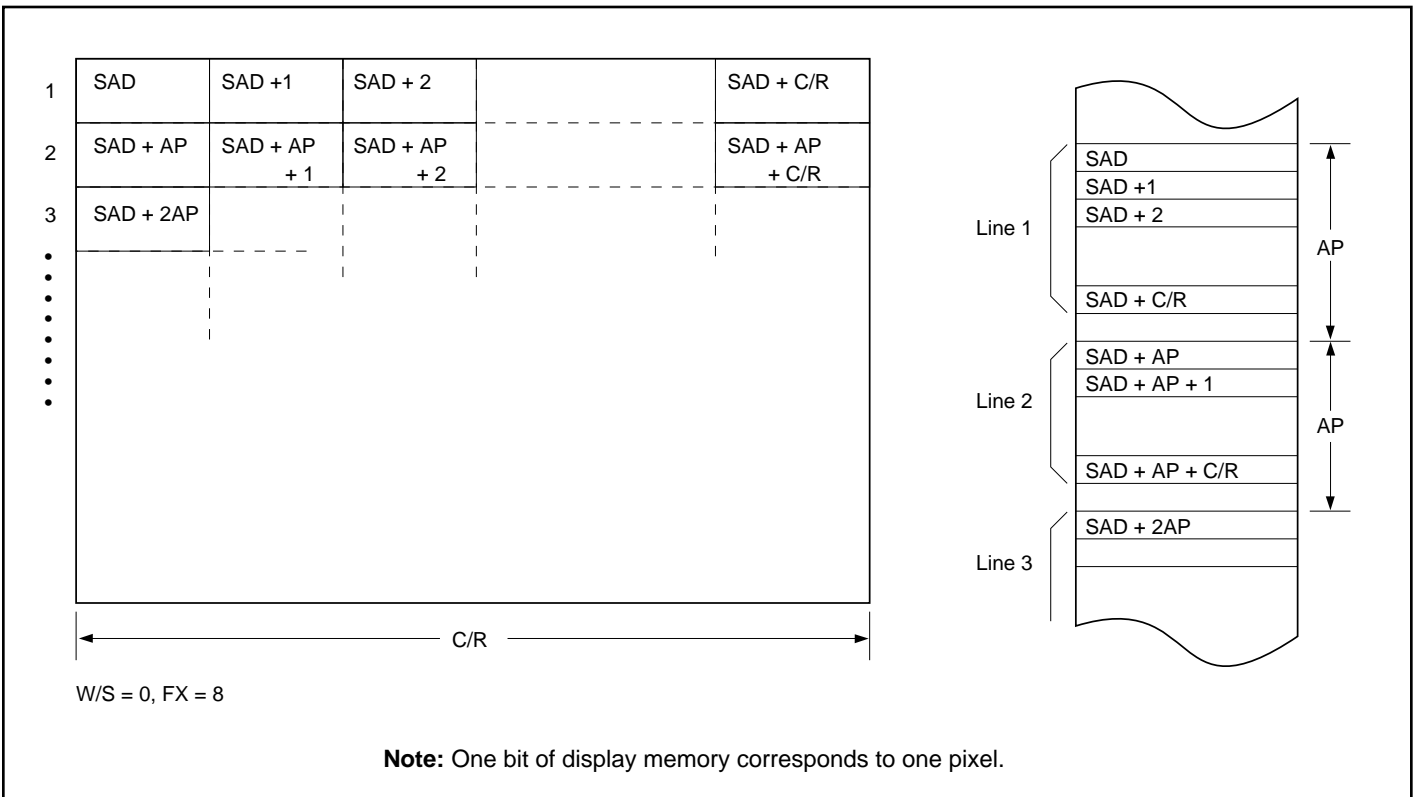
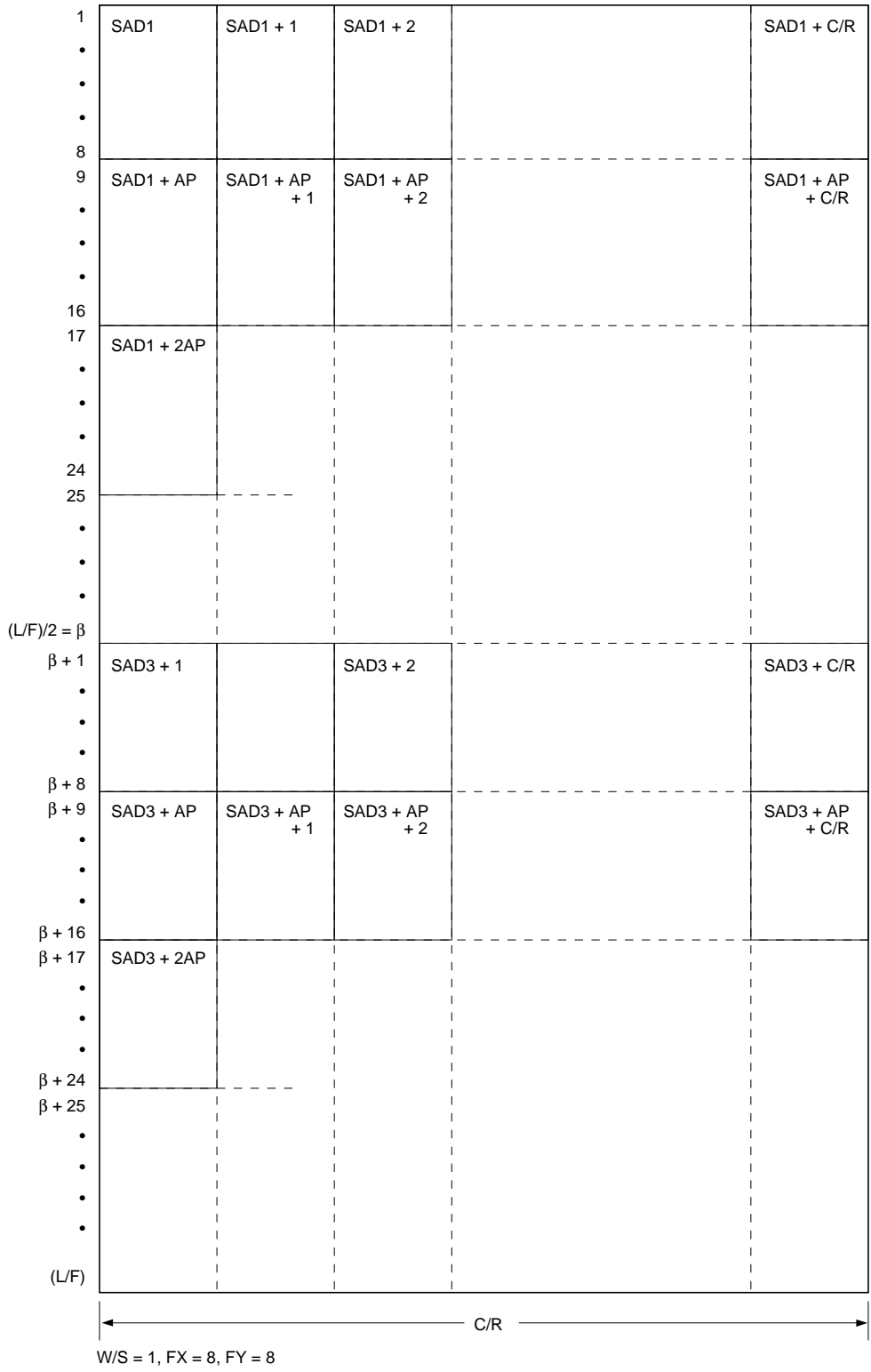

Figure 50. Character parameters vs. memory



**Note:** In two-panel drive, the SED1330F/1335F/1336F reads line 1 and line β + 1 as one cycle. The upper and lower panels are thus read alternately, one line at a time.

Figure 51. Two-panel display address indexing

5.2.3 Display Scan Timing

Figure 44 shows the basic timing of the SED1330F/1335F/1336F. One display memory read cycle takes nine periods of the system clock,  $\phi_0$  ( $f_{OSC}$ ). This cycle repeats ( $C/R + 1$ ) times per display line.

When reading, the display memory pauses at the end of each line for  $(TC/R - C/R)$  display memory read

cycles, though the LCD drive signals are still generated.  $TC/R$  may be set to any value within the constraints imposed by  $C/R$ ,  $f_{OSC}$ ,  $f_{FR}$ , and the size of the LCD panel, and it may be used to fine tune the frame frequency. The microprocessor may also use this pause to access the display memory data.

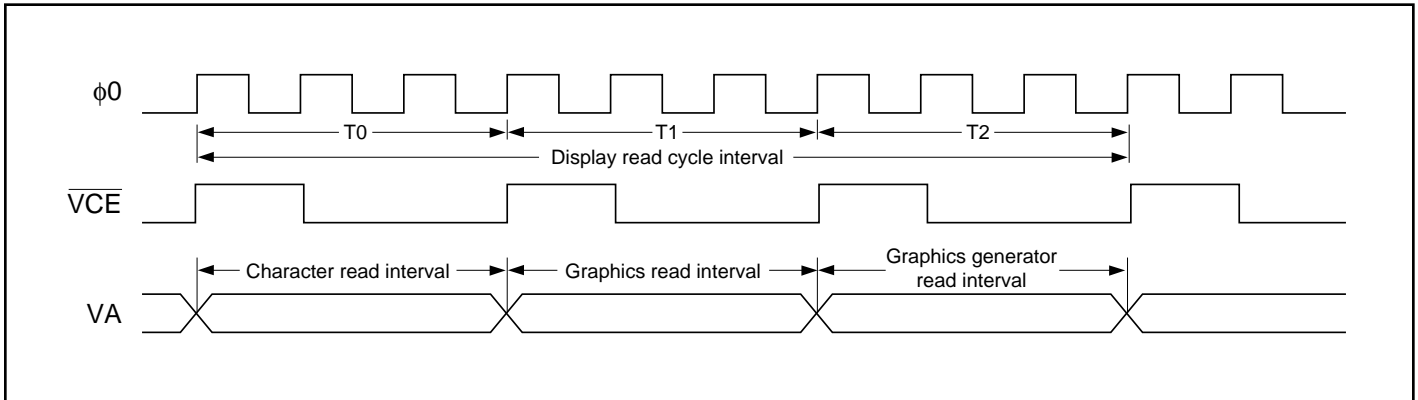
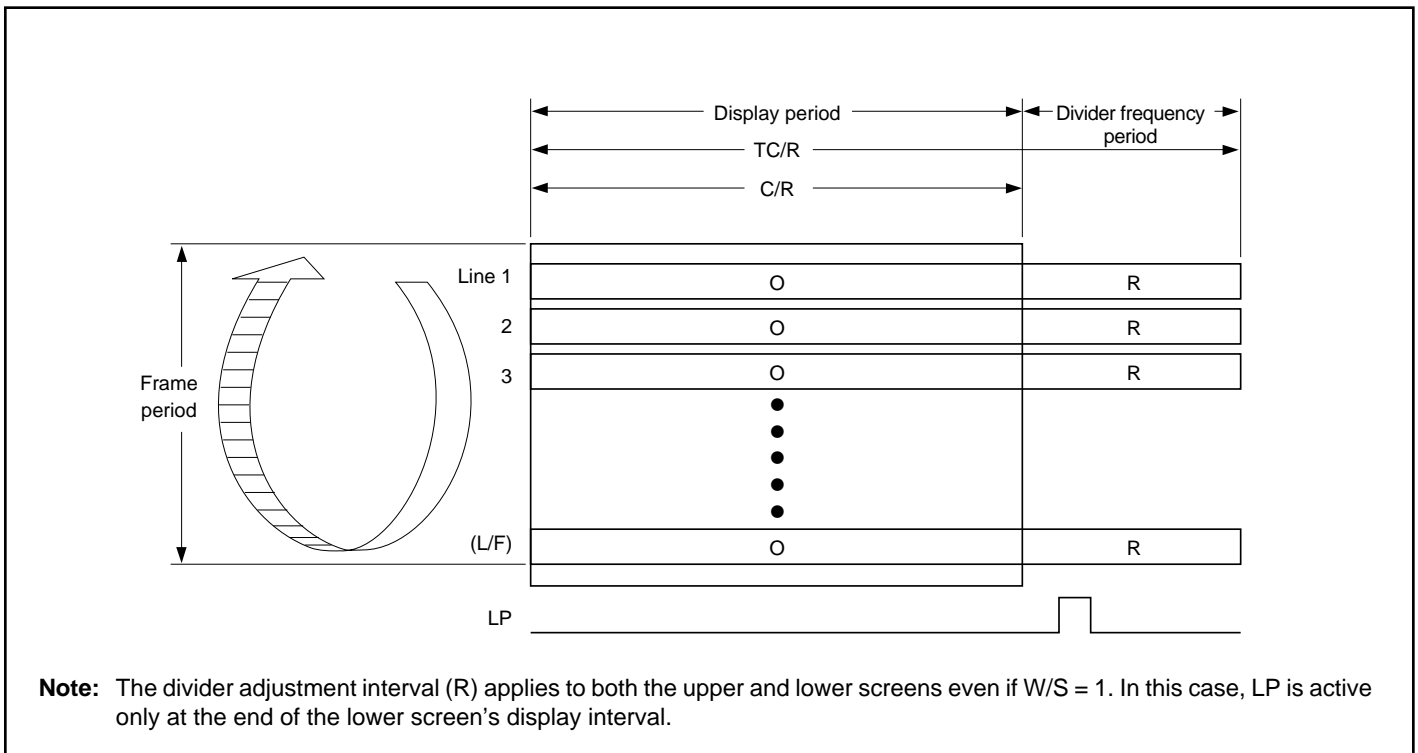

Figure 52. Display memory basic read cycle



**Note:** The divider adjustment interval (R) applies to both the upper and lower screens even if  $W/S = 1$ . In this case, LP is active only at the end of the lower screen's display interval.

Figure 53. Relationship between  $TC/R$  and  $C/R$

5.3 Cursor Control

5.3.1 Cursor Register Function

The SED1330F/1335F/1336F cursor address register functions as both the displayed cursor position address register and the display memory access address register. When accessing display memory outside the actual screen memory, the address register must be saved before accessing the memory and restored after memory access is complete.

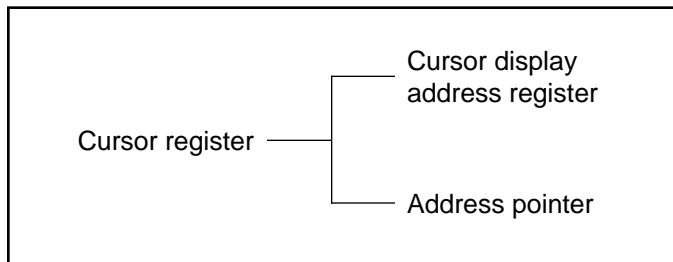

Figure 54. Cursor addressing

Note that the cursor may disappear from the display if the cursor address remains outside the displayed screen memory for more than a few hundred milliseconds.

5.3.2 Cursor Movement

On each memory access, the cursor address register changes by the amount previously specified with CSRDIR, automatically moving the cursor to the desired location.

5.3.3 Cursor Display Layers

Although the SED1330F/1335F/1336F can display up to three layers, the cursor is displayed in only one of these layers:

Two-layer configuration: First layer (L1)

Three-layer configuration: Third layer (L3)

The cursor will not be displayed if it is moved outside the memory for its layer. Layers may be swapped or

the cursor layer moved within the display memory if it is necessary to display the cursor on a layer other than the present cursor layer.

Although the cursor is normally displayed for character data, the SED1330F/1335F/1336F may also display a dummy cursor for graphical characters. This is only possible if the graphics screen is displayed, the text screen is turned off and the microprocessor generates the cursor control address.

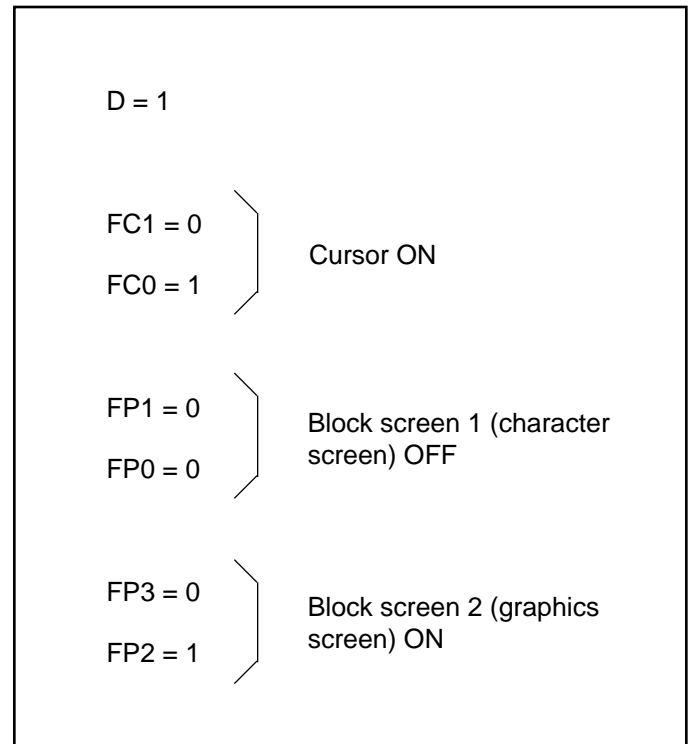

Figure 55. Cursor display layers

Consider the example of displaying Chinese characters on a graphics screen. To write the display data, the cursor address is set to the second screen block, but the cursor is not displayed. To display the cursor, the cursor address is set to an address within the blank text screen block.

Since the automatic cursor increment is in address units, not character units, the controlling microprocessor must set the cursor address register when moving the cursor over the graphical characters.

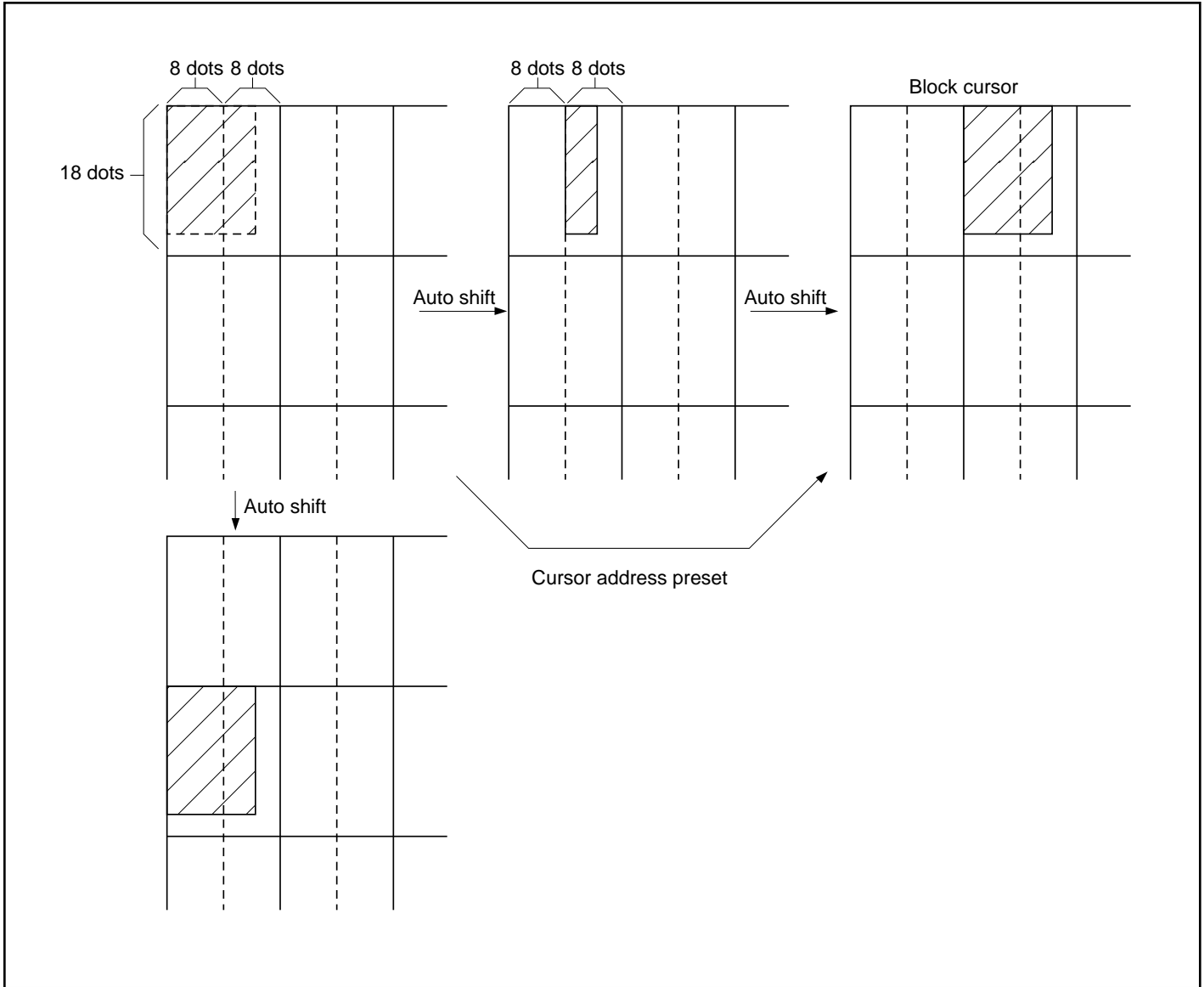

Figure 56. Cursor movement

If no text screen is displayed, only a bar cursor can be displayed at the cursor address.

If the first layer is a mixed text and graphics screen and the cursor shape is set to a block cursor, the

SED1330F/1335F/1336F automatically decides which cursor shape to display. On the text screen it displays a block cursor, and on the graphics screen, a bar cursor.

5.4 Memory to Display Relationship

The SED1330F/1335F/1336F supports virtual screens that are larger than the physical size of the LCD panel address range, C/R. A layer of the SED1330F/1335F/1336F can be considered as a window in the larger virtual screen held in display memory. This window can be divided into two

blocks, with each block able to display a different portion of the virtual screen.

This enables, for example, one block to dynamically scroll through a data area while the other acts as a status message display area. See Figure 49 and 50.

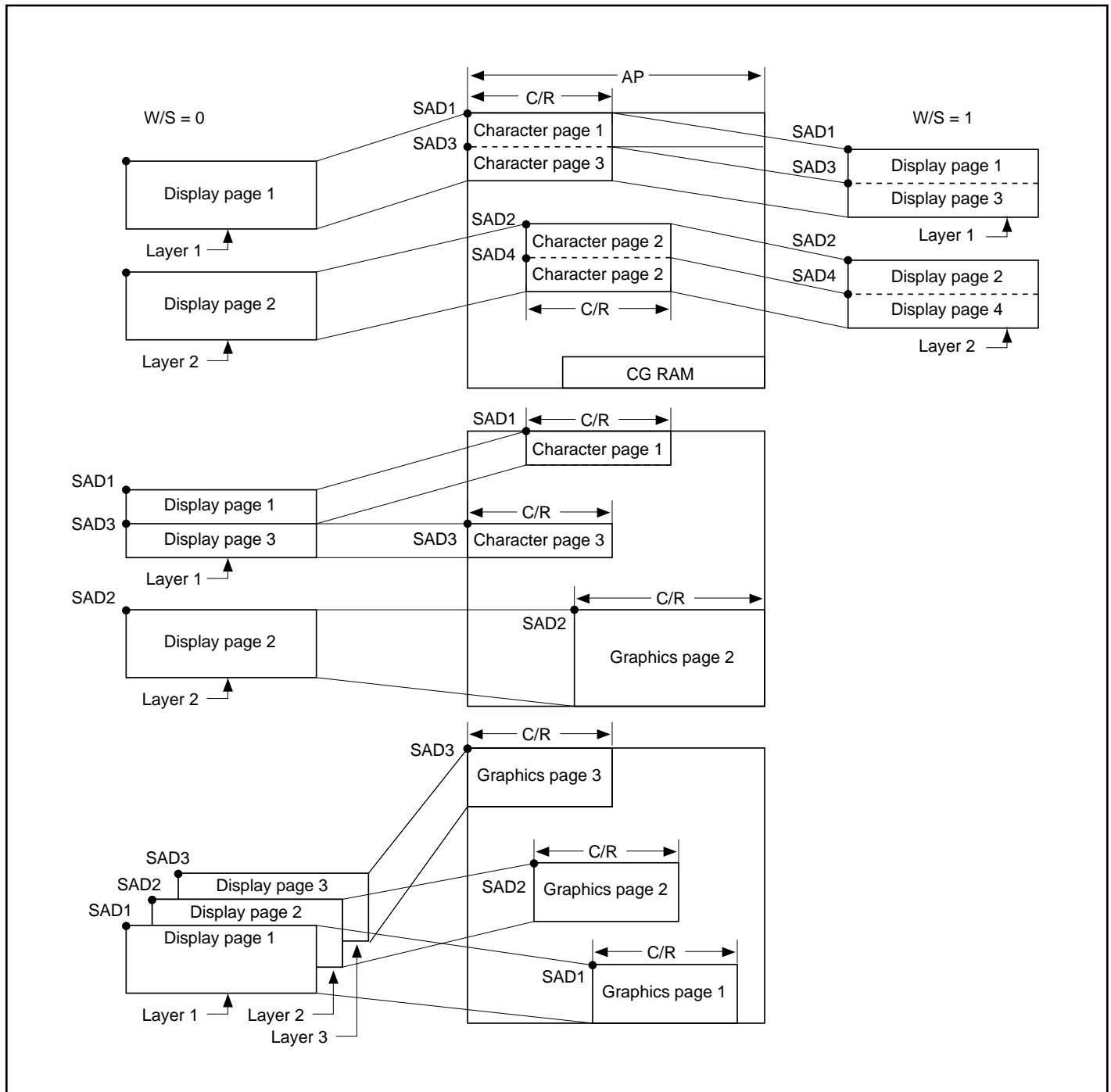

Figure 57. Display layers of memory

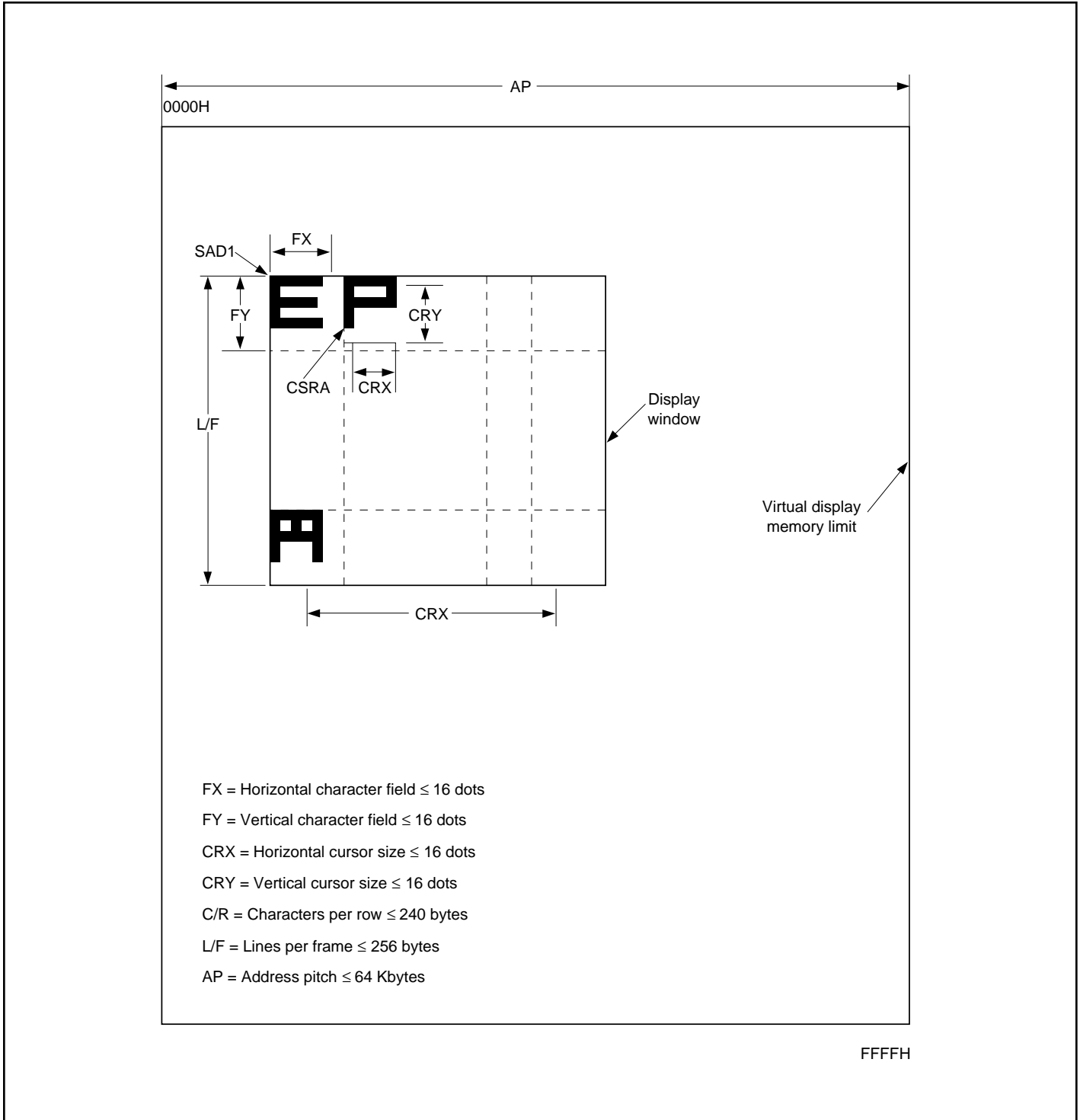

Figure 58. Display window and memory



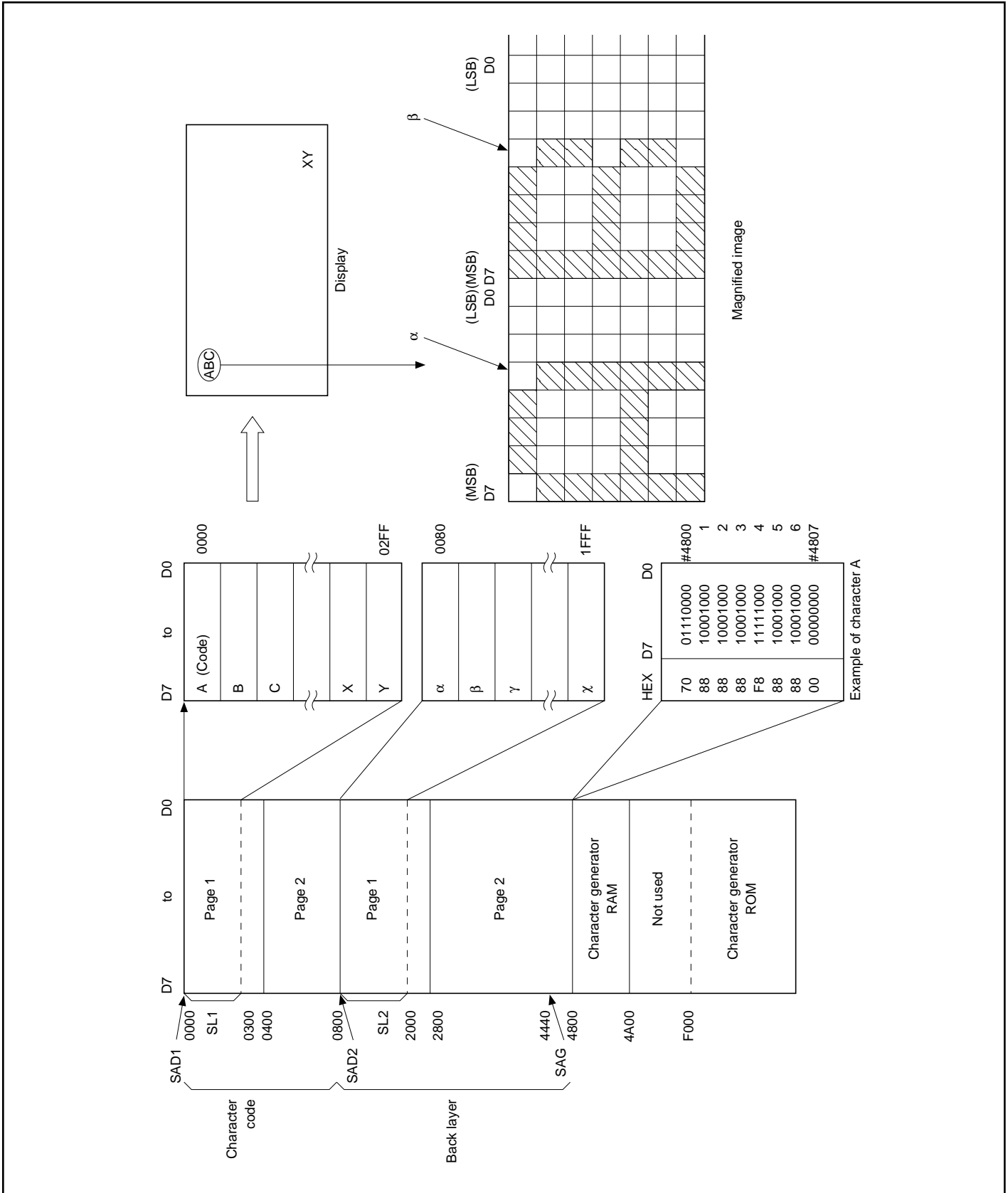

Figure 59. Memory map and magnified characters

5.5 Scrolling

The controlling microprocessor can set the SED1330F/1335F/1336F scrolling modes by overwriting the scroll address registers SAD1 to SAD4, and by directly setting the scrolling mode and scrolling rate.

5.5.1 On-page Scrolling

The normal method of scrolling within a page is to move the whole display up one line and erase the bottom line. Since the SED1330F/1335F/1336F does not automatically erase the bottom line, it must be erased with blanking data when changing the scroll address register.

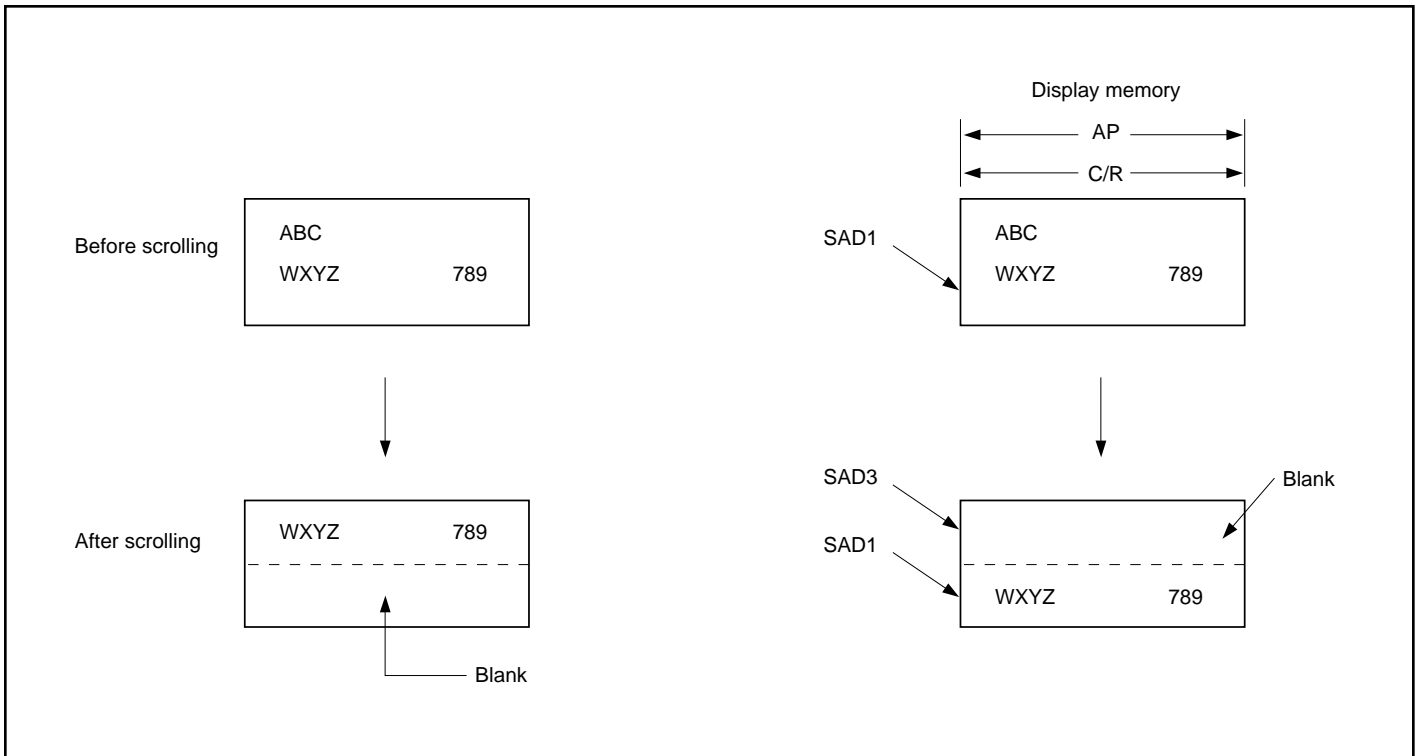

Figure 60. On-page scrolling

5.5.2 Inter-page Scrolling

Scrolling between pages and page switching can be performed only if the display memory capacity is greater than one screen.

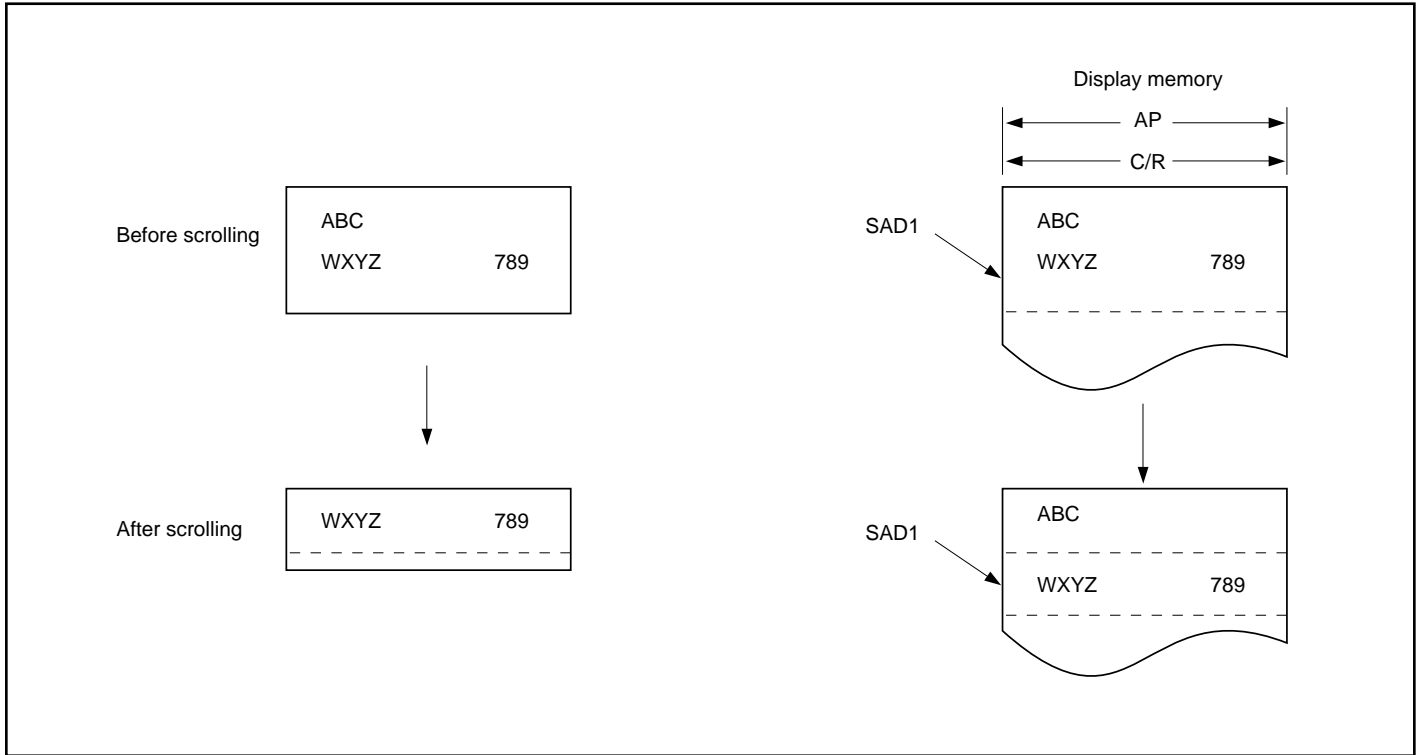

Figure 61. Inter-page scrolling

## 5.5.3 Horizontal Scrolling

The display can be scrolled horizontally in one-character units, regardless of the display memory capacity.

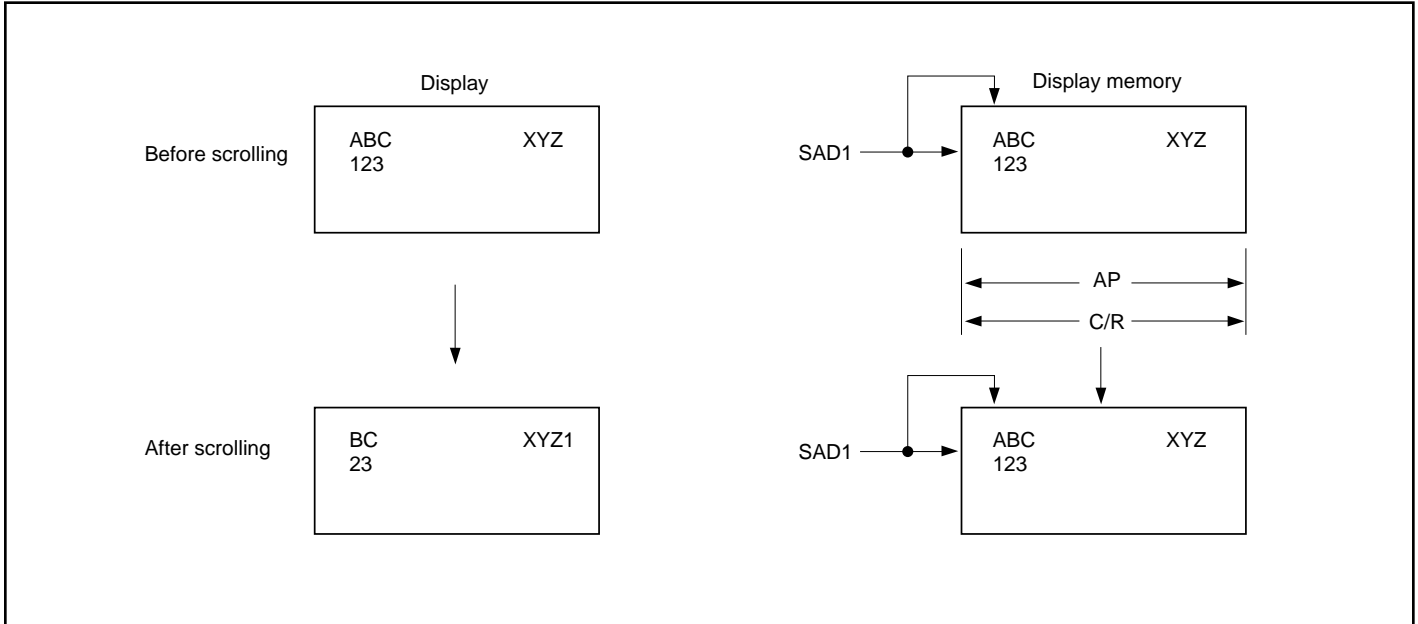

Figure 62. Horizontal wraparound scrolling

Refer to Section 9.4 for application notes.

5.5.4 Bidirectional Scrolling

Bidirectional scrolling can be performed only if the display memory is larger than the physical screen both horizontally and vertically. Although scrolling is normally done in single-character units, the HDOT

SCR command can be used to scroll horizontally in pixel units. Single-pixel scrolling both horizontally and vertically can be performed by using the SCROLL and HDOT SCR commands. See Section 9.4

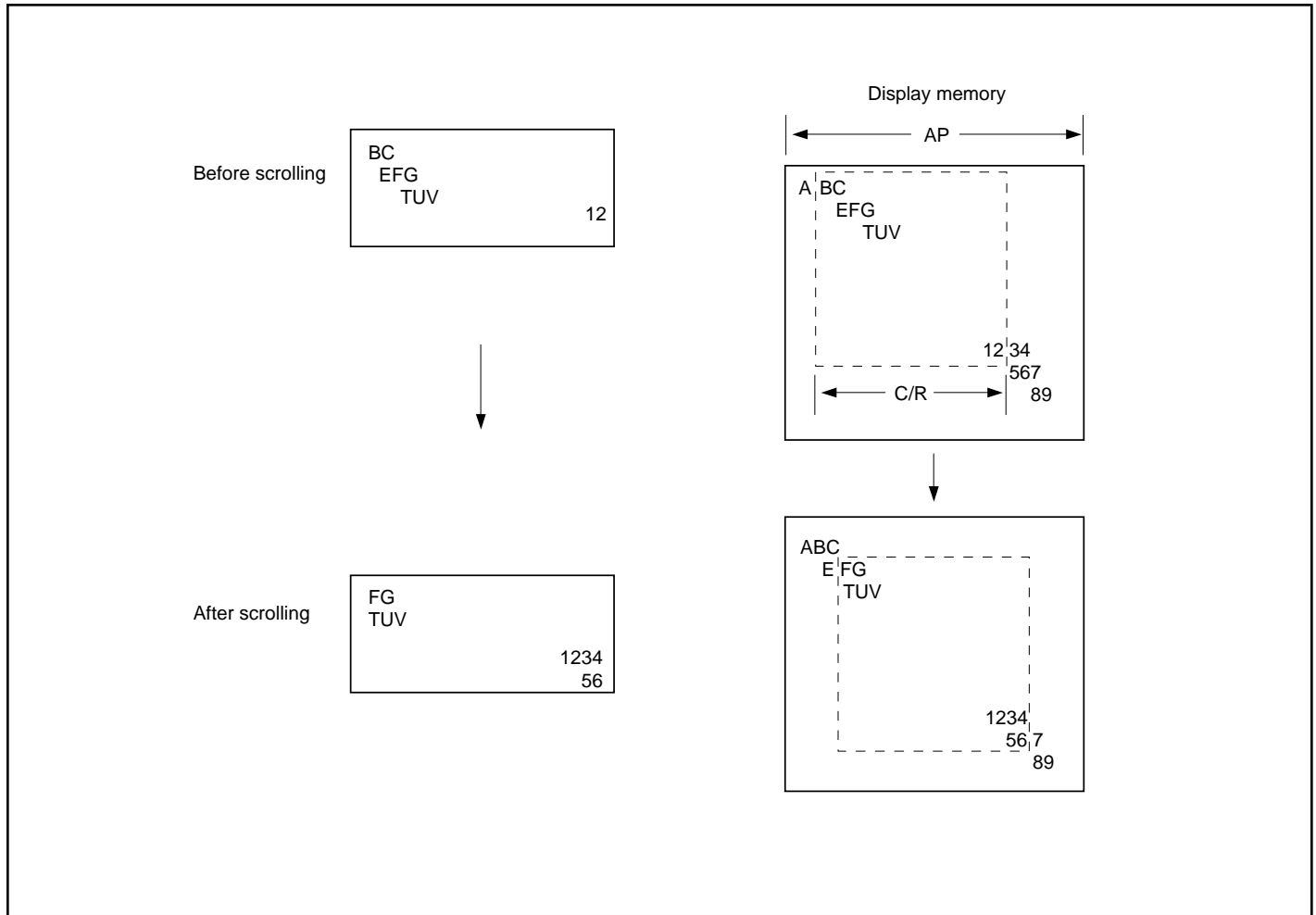

Figure 63. Bidirectional scrolling

5.5.5 Scroll Units

Table 21. Scroll units

Mode	Vertical	Horizontal
Text	Characters	Pixels or characters
Graphics	Pixels	Pixels

Note that in a divided screen, each block cannot be independently scrolled horizontally in pixel units.

**THIS PAGE INTENTIONALLY BLANK**

# **6.0**

## ***Character Generator***

**THIS PAGE INTENTIONALLY BLANK**



## 6.0 Character Generator

### 6.1 CG Characteristics

#### 6.1.1 Internal Character Generator

The internal character generator is recommended for minimum system configurations containing a SEDSED1330F/1335F/1336F, display RAM, LCD panel, single-chip microprocessor and power supply. Since the internal character generator uses a CMOS mask ROM, it is also recommended for low-power applications.

- 5 × 7-pixel font (See Section 10)
- 160 JIS standard characters
- Can be mixed with character generator RAM (maximum of 64 CG RAM characters)
- Can be automatically spaced out up to 8 × 16 pixels

#### 6.1.2 External Character Generator ROM

The external CG ROM can be used when fonts other than those in the internal ROM are needed. Data is stored in the external ROM in the same format used in the internal ROM. (See Section 6.3.)

- Up to 8 × 8-pixel characters (M2 = 0) or 8 × 16-pixel characters (M2 = 1)
- Up to 256 characters (192 if used together with the internal ROM)

- Mapped into the display memory address space at F000H to F7FFH (M2 = 0) or F000H to FFFFH (M2 = 1)
- Characters can be up to 8 × 16-pixels; however, excess bits must be set to zero.

#### 6.1.3 Character Generator RAM

The user can freely use the character generator RAM for storing graphics characters. The character generator RAM can be mapped by the microprocessor anywhere in display memory, allowing effective use of unused address space.

- Up to 8 × 8-pixel characters (M2 = 0) or 8 × 16 characters (M2 = 1)
- Up to 256 characters if mapped at F000H to FFFFH (64 if used together with character generator ROM)
- Can be mapped anywhere in display memory address space if used with the character generator ROM
- Mapped into the display memory address space at F000H to F7FFH if not used with the character generator ROM (more than 64 characters are in the CG RAM). Set SAG0 to F000H and M1 to zero when defining characters number 193 upwards.

6.2 CG Memory Allocation

Since the SED1335F/1336F uses 8-bit character codes, it can handle no more than 256 characters at a time. However, if a wider range of characters is

required, character generator memory can be bank-switched using the CGRAM ADR command.

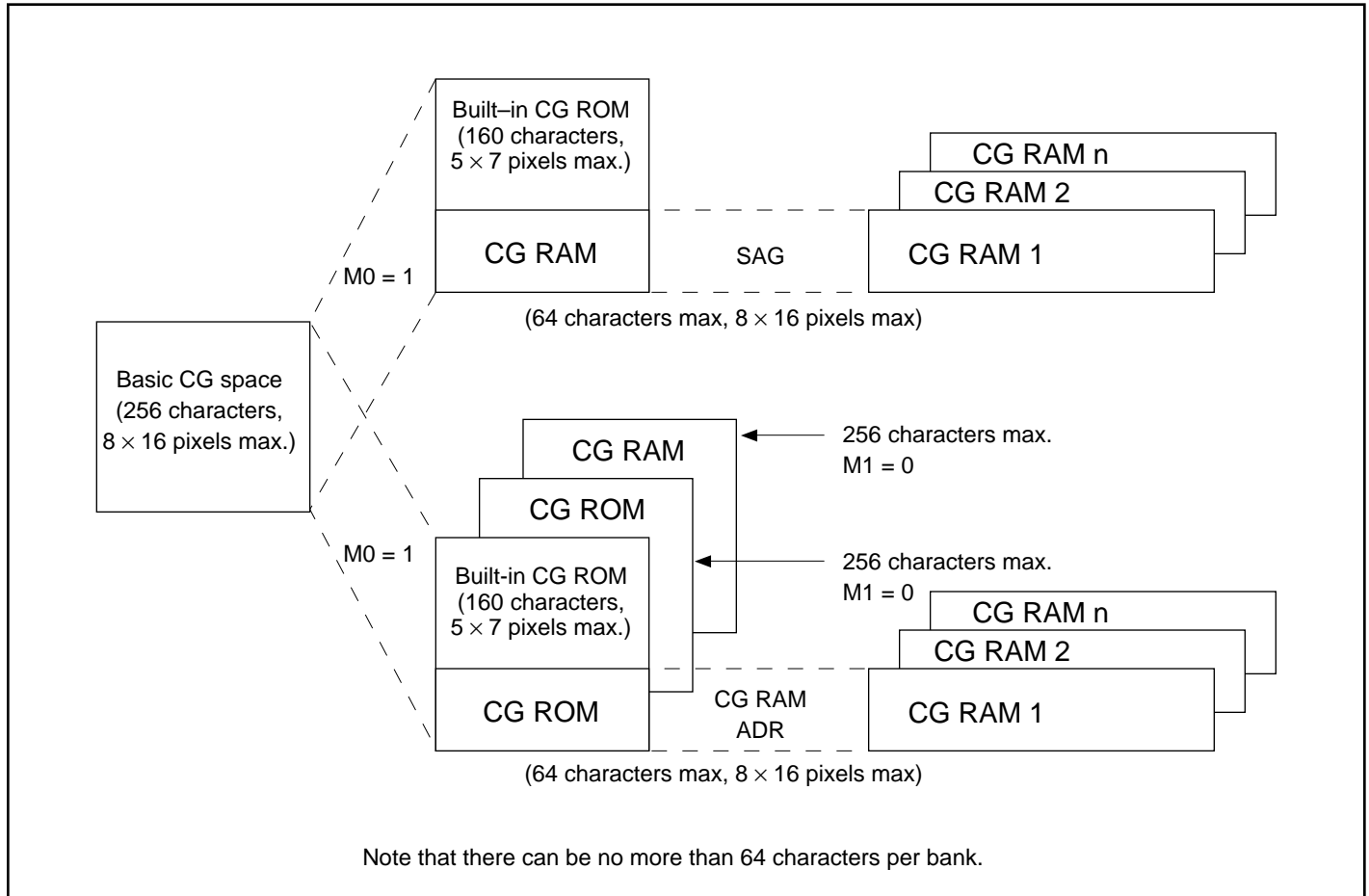

Figure 64. Internal and external character mapping

Table 22. Character mapping

Item		Parameter	Remarks
Internal/external character generator selection		M0	
Character field height	1 to 8 pixels	M2 = 0	
	9 to 16 pixels	M2 = 1	
	Greater than 16 pixels	Graphics mode (8 bits × 1 line)	
Internal CG ROM/RAM select		Automatic	Determined by the character code
External CG ROM/RAM select			
CG RAM bit 6 correction		M1	
CG RAM data storage address		Specified with CG RAM ADR command	Can be moved anywhere in the display memory address space
External CG ROM address	192 characters or less	Other than the area of Figure 58	
	More than 192 characters	Set SAG to F000H and overly SAG and the CG ROM table.	

### 6.3 Setting the Character Generator Address

The CG RAM addresses in the VRAM address space are not mapped directly from the address in the SAG register. The data to be displayed is at a CG RAM

address calculated from SAG + character code + ROW select address. This mapping is shown in Tables 23 and 24.

Table 23. Character fonts, number of lines ≤ 8 (M2 = 0, M1 = 0)

SAG	A15	A14	A13	A12	A11	A10	A9	A8	A7	A6	A5	A4	A3	A2	A1	A0
Character code	0	0	0	0	0	D7	D6	D5	D4	D3	D2	D1	D0	0	0	0
+ROW select address	0	0	0	0	0	0	0	0	0	0	0	0	0	R2	R1	R0
CG RAM address	VA15	VA14	VA13	VA12	VA11	VA10	VA9	VA8	VA7	VA6	VA5	VA4	VA3	VA2	VA1	VA0

Table 24. Character fonts, 9 ≤ number of lines ≤ 16 (M2 = 1, M1 = 0)

SAG	A15	A14	A13	A12	A11	A10	A9	A8	A7	A6	A5	A4	A3	A2	A1	A0
Character code	0	0	0	0	D7	D6	D5	D4	D3	D2	D1	D0	0	0	0	0
+ROW select address	0	0	0	0	0	0	0	0	0	0	0	0	R3	R2	R1	R0
CG RAM address	VA15	VA14	VA13	VA12	VA11	VA10	VA9	VA8	VA7	VA6	VA5	VA4	VA3	VA2	VA1	VA0

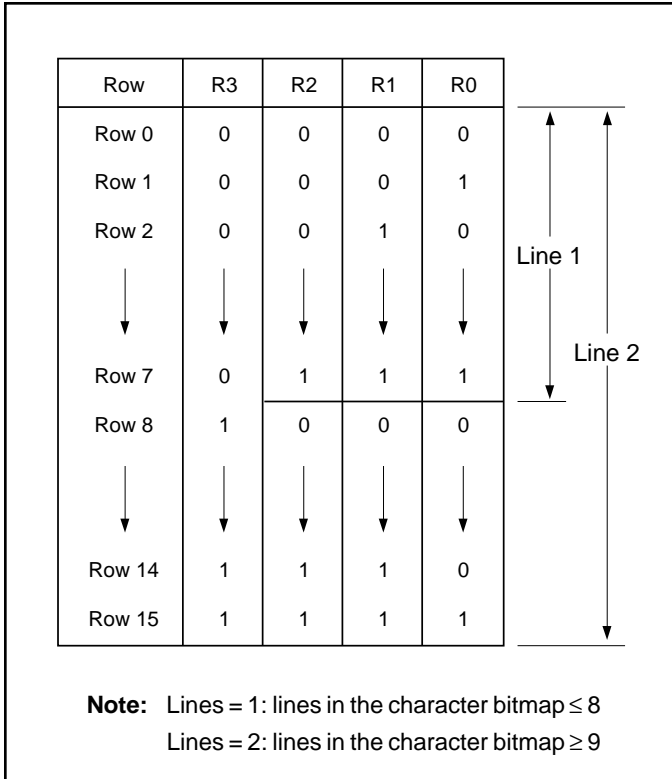

Figure 65. Row select address

6.3.1 M1 = 1

The SED1335F/1336F automatically converts all bits set in bit 6 of character code for CG RAM 2 to zero. Because of this, the CG RAM data areas become contiguous in display memory.

When writing data to CG RAM:

- Calculate the address as for M1 = 0.
- Change bit 6 of the character code from “1” to “0”.

6.3.2 CG RAM Addressing Example

- Define a pattern for the “A” in Figure 38.
- The CG RAM table start address is 4800H.
- The character code for the defined pattern is 80H (the first character code in the CG RAM area).

As the character code table in Figure 58 shows, codes 80H to 9FH and E0H to FFH are allocated to the CG RAM and can be used as desired. 80H is thus the first code for CG RAM. As characters cannot be used if only using graphics mode, there is no need to set the CG RAM data.

Table 25. Character data example

CGRAM ADR	5CH	Reverse the CG RAM address calculation to calculate SAG
P1	00H	
P2	40H	
CSRDIR	4CH	Set cursor shift direction to right
CSRW	46H	CG RAM start address is 4800H
P1	00H	
P2	48H	
MWRITE	42H	
P	70H	Write ROW 0 data
P2	88H	Write ROW 1 data
P3	88H	Write ROW 2 data
P4	88H	Write ROW 3 data
P5	F8H	Write ROW 4 data
P6	88H	Write ROW 5 data
P7	88H	Write ROW 6 data
P8	00H	Write ROW 7 data
P8	00H	Write ROW 8 data
↓	↓	↓
P16	00H	Write ROW 15 data

6.4 Character Codes

The following figure shows the character codes and the codes allocated to CG RAM. All codes can be used by the CG RAM if not using the internal ROM.

Lower 4 bits	Upper 4 bits															
	0	1	2	3	4	5	6	7	8	8	A	B	C	D	E	F
0				0	@	P	'	p				-	夕	三		
1			!	1	A	Q	a	q			。	ア	チ	厶		
2			"	2	B	R	b	r			「	イ	ツ	メ		
3			#	3	C	S	c	s			」	ウ	テ	モ		
4			\$	4	D	T	d	t			、	エ	ト	ヤ		
5			%	5	E	U	e	u			•	オ	ナ	ユ		
6			&	6	F	V	f	v			ヲ	カ	ニ	ヨ		
7			'	7	G	W	g	w			ヲ	キ	ヌ	ラ		
8			(	8	H	X	h	x			イ	ク	ネ	リ		
9			)	9	I	Y	i	y			ウ	ケ	ル	ル		
A			*	:	J	Z	j	z			エ	コ	ル	レ		
B			+	;	K	[	k	{			オ	ケ	ヒ	□		
C			,	<	L	¥	l				ハ	シ	フ	ワ		
D			.	+	M	]	m	}			ユ	ス	ハ	シ		
E			-	▷	N	^	n	→			ヨ	セ	ホ	、		
F			/	?	O	_	o	←			ツ	リ	マ	□		

Figure 66. On-chip character codes

**THIS PAGE INTENTIONALLY BLANK**

**7.0**  
***TV Mode***  
***(SED1336F only)***

**THIS PAGE INTENTIONALLY BLANK**



7.0 TV Mode (SED1336F only)

When used with an external video mixer circuit, the SED1336F can show the same display on a television as on the LCD panel. In addition, the changeover from LCD-only to TV-and-LCD display is instantaneous with the changing of the T/L register using the System Set instruction.

The TV and LCD display register parameters which are determined by hardware constraints are shown in Table 26.

Table 26. Register parameters

System	TC/R (Hex)	C/R (Hex)	L/F (Hex)	Clock Cycles per Horizontal Line	Oscillator Frequency, fo (MHz)	T/L
NTSC	2A	1F	C7	388	6.1050	1
PAL	2A	1F	C7	388	6.0625	1
LCD	≥ 2A	1F	C7	≥ 388	6.0625 or 6.1050	0

7.1 Sync Generator Circuit Timing

The NTSC and PAL vertical sync signal waveforms are shown in Figure 59 and 60, respectively. The

vertical sync timing parameters and VSD output states are shown in Table 27.

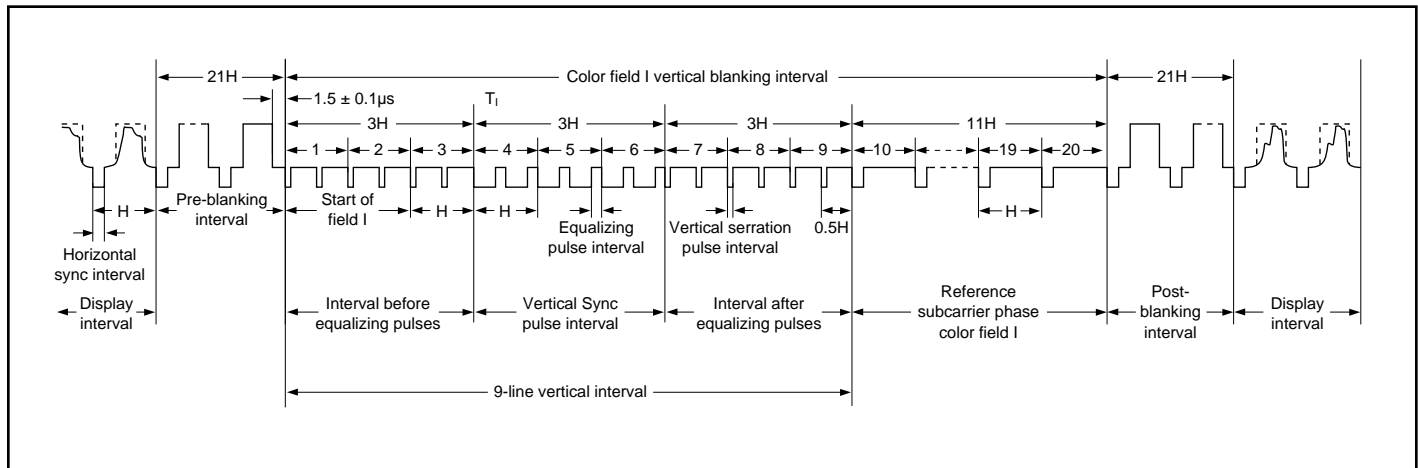

Figure 67. NTSC vertical sync waveform

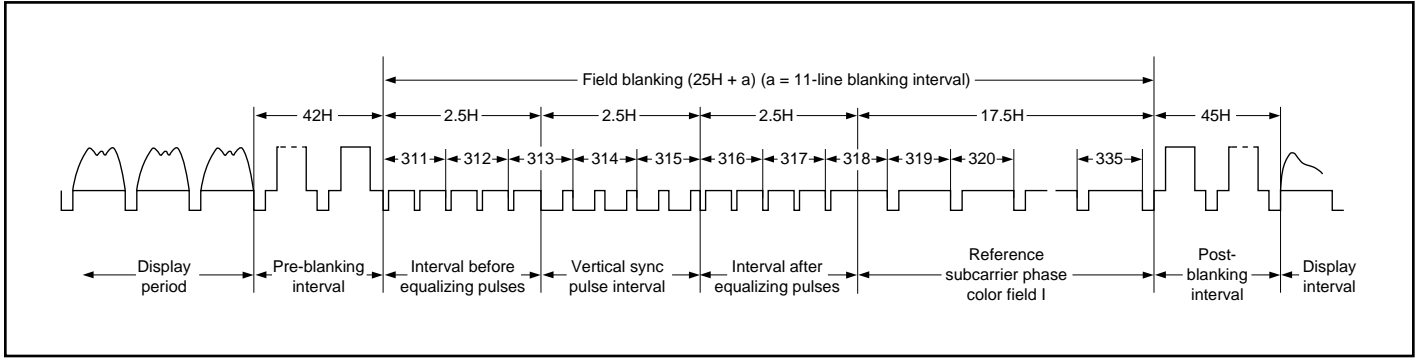

Figure 68. PAL vertical sync waveform

Table 27. Vertical sync timing characteristics

Parameter	Pre-blanking Interval	Interval before Equalizing Pulse	Vertical Sync Pulse Interval	Interval after Equalizing Pulse	Reference Subcarrier Phase Color Field I	Post-blanking Interval	Display Interval	Equalizing Pulse Interval	Vertical Serration Pulse Interval
NTSC system timing	21H	3H	3H	3H	11H	21H	200H	15CK	27CK
PAL system timing	42H	2.5H	2.5H	2.5H	17.5H	45H	200H	15CK	27CK
VSD output level	High impedance	LOW	LOW	LOW	LOW	High impedance	LOW or high impedance	—	—

Notes:

1. The NTSC system uses 262 lines per screen, and the PAL system, 312.
2. H = Horizontal line period  
CK = Oscillator period

The horizontal sync signal waveforms are shown in Figure 61, and the timing parameters and VSD output

states, in Table 28. Note that SNC and VSD are both high-impedance when in LCD mode.

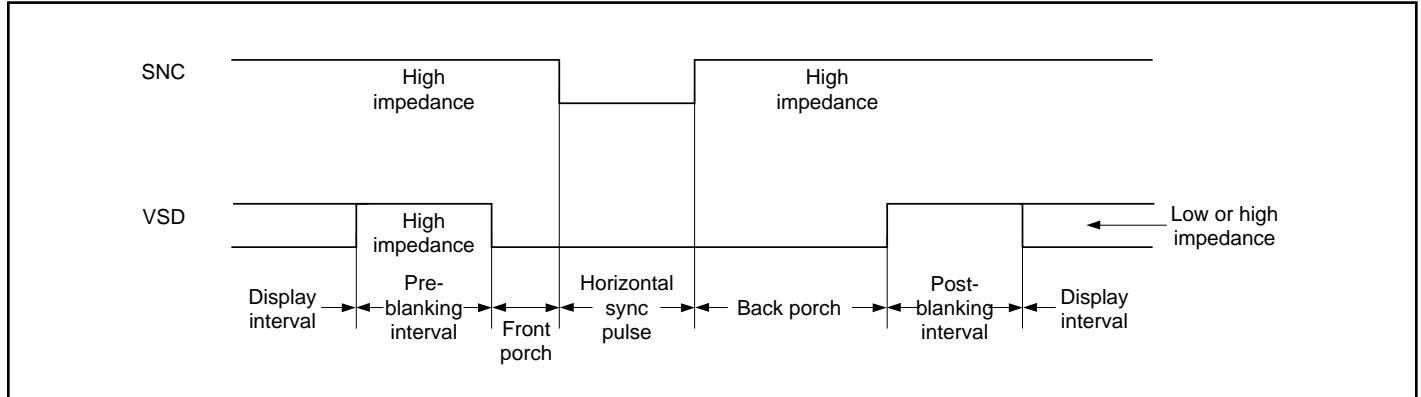

Figure 69. Horizontal sync waveforms

Table 28. Horizontal sync characteristics

Parameter	Pre-blanking Interval	Front Porch	Horizontal Sync Pulse	Back Porch	Post-blanking Interval	Display Interval
NTSC system timing	29CK	10CK	29CK	28CK	36CK	256CK
PAL system timing	29CK	10CK	29CK	34CK	30CK	256CK
VSD output level	High impedance	LOW	LOW	LOW	High impedance	LOW or High impedance

**THIS PAGE INTENTIONALLY BLANK**

# 8.0

## *Description of Circuit Blocks*

**THIS PAGE INTENTIONALLY BLANK**

## 8.0 Description of Circuit Blocks

### 8.1 Microprocessor Interface

#### 8.1.1 System Bus Interface

SEL1, SEL2 (SED1330F and SED1335F only), A0,  $\overline{RD}$ ,  $\overline{WR}$  and  $\overline{CS}$  are used as control signals for the microprocessor data bus. A0 is normally connected to the lowest bit of the system address bus. SEL1 and SEL2 change the operation of the  $\overline{RD}$  and  $\overline{WR}$  pins to enable interfacing to either an 8080 or 6800 family bus, and should have either a pull-up or a pull-down resistor.

With microprocessors using an 8080 family interface, the SED1330F/1335F/1336F is normally mapped into the I/O address space.

##### 8.1.1.1 8080 series

Table 29. 8080 series interface signals

A0	$\overline{RD}$	$\overline{WR}$	Function
0	0	1	Status flag read
1	0	1	Display data and cursor address read
0	1	0	Display data and parameter write
1	1	0	Command write

##### 8.1.1.2 6800 series

Table 30. 6800 series interface signals

A0	$\overline{RD}$	$\overline{WR}$	Function
0	1	1	Status flag read
1	1	1	Display data and cursor address read
0	0	1	Display data and parameter write
1	0	1	Command write

#### 8.1.2 Microprocessor Synchronization

The SED1330F/1335F/1336F interface operates at full bus speed, completing the execution of each command within the cycle time,  $t_{CYC}$ . The controlling micro-processor's performance is thus not hampered by polling or handshaking when accessing the SED1330F/1335F/1336F.

Display flicker may occur if there is more than one consecutive access that cannot be ignored within a frame. The microprocessor can minimize this either by performing these accesses intermittently, or by continuously checking the status flag (D6) and waiting for it to become HIGH.

##### 8.1.2.1 Display Status Indication Output (For SED1336 only)

When  $\overline{CS}$ , A0 and  $\overline{RD}$  are LOW, D6 functions as the display status indication output. It is HIGH during the TV-mode vertical retrace period or the LCD-mode horizontal retrace period, and LOW, during the period the controller is writing to the display. By monitoring D6 and writing to the data memory only during retrace periods, the display can be updated without causing screen flicker.

##### 8.1.2.2 Internal Register Access

The SYSTEM SET and SLEEP IN commands can be used to perform input/output to the SED1330F/1335F/1336F independently of the system clock frequency. These are the only commands that can be used while the SED1330F/1335F/1336F is in sleep mode.

##### 8.1.2.3 Display Memory Access

The SED1330F/1335F/1336F supports a form of pipelined processing, in which the microprocessor

synchronizes its processing to the SED1330F/1335F/1336F's timing. When writing, the microprocessor first issues the MWRITE command. It then repeatedly writes display data to the SED1336F using the system bus timing. This ensures that the microprocessor is not slowed down even if the display memory access times are slower than the system bus access times. See Figure 70.

When reading, the microprocessor first issues the MREAD command, which causes the SED1330F/1335F/1336F to load the first read data into its output buffer. The microprocessor then reads data from the SED1330F/1335F/1336F using the system bus timing. With each read, the SED1330F/1335F/1336F reads the next data item from the display memory ready for the next read access. See Figure 71.

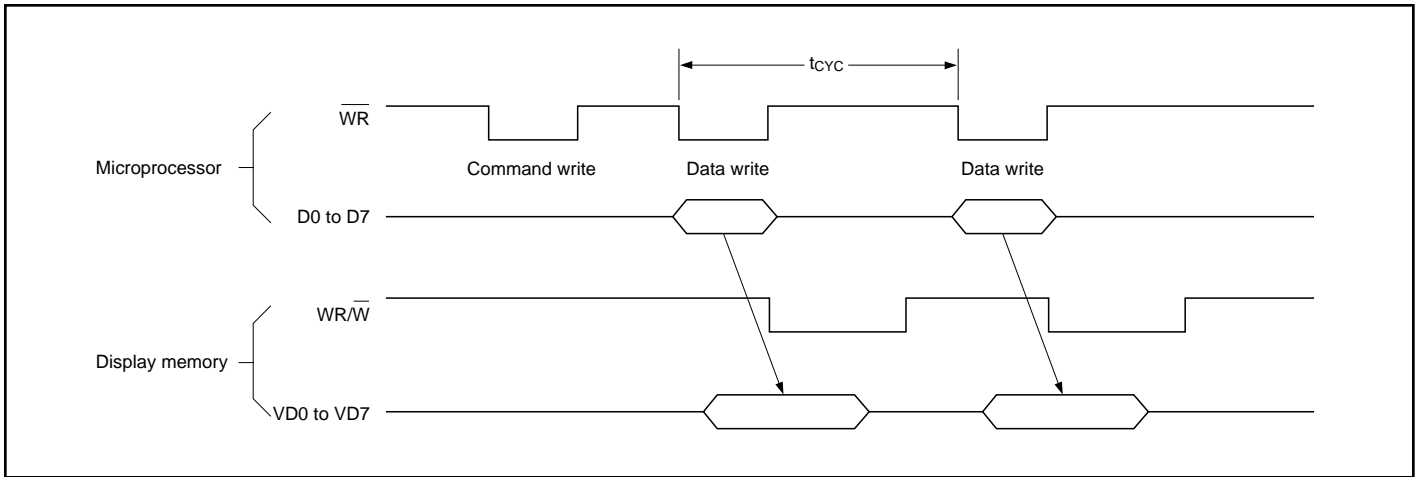

Figure 70. Display memory write cycle

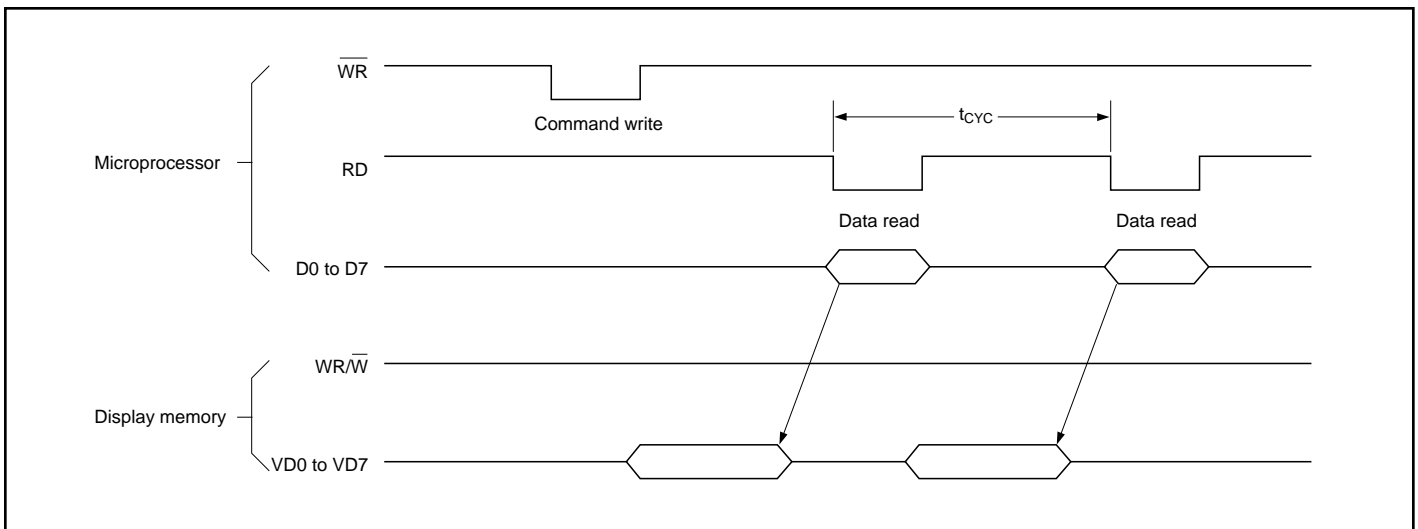

Figure 71. Display memory read cycle

**Note:** A possible problem with the display memory read cycle is that the system bus access time,  $t_{ACC}$ , does not depend on the display memory access time,  $t_{ACV}$ . The microprocessor may only make repeated reads if the read loop time exceeds the SED1330F/1335F/1336F cycle time,  $t_{CYC}$ . If it does not, NOP instructions may be inserted in the program loop.  $t_{ACC}$ ,  $t_{ACV}$  and  $t_{CYC}$  limits are given in Section 4.3.



8.1.3 Interface Examples

8.1.3.1 Z80® to SED1330F/1335F/1336F Interface

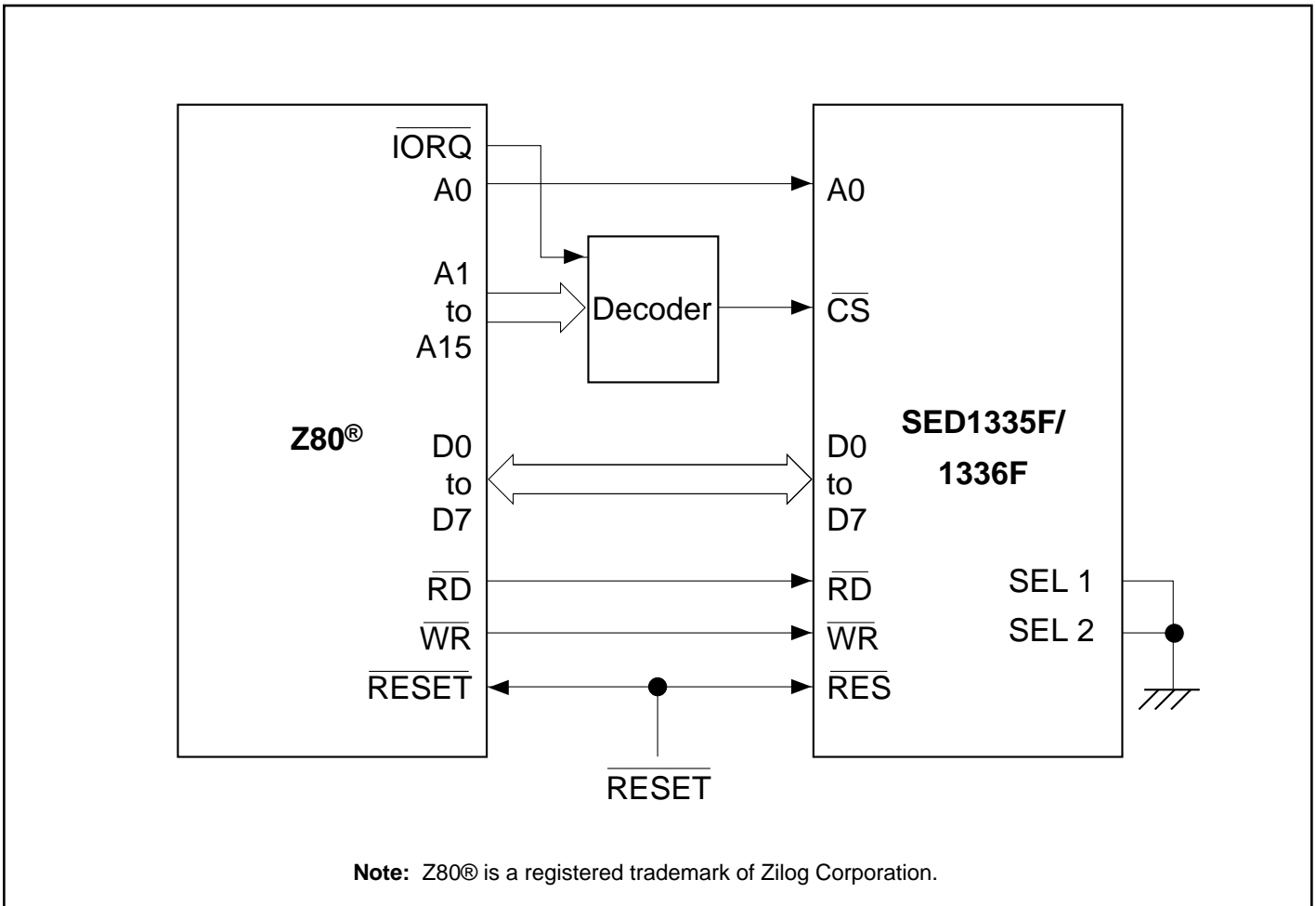

Figure 72. Z80® to SED1330F/1335F/1336F\* interface

**Note:** \*For SED1336F: SEL 2 is open..

8.1.3.2 6802 to SED1330F/1335F/1336F Interface

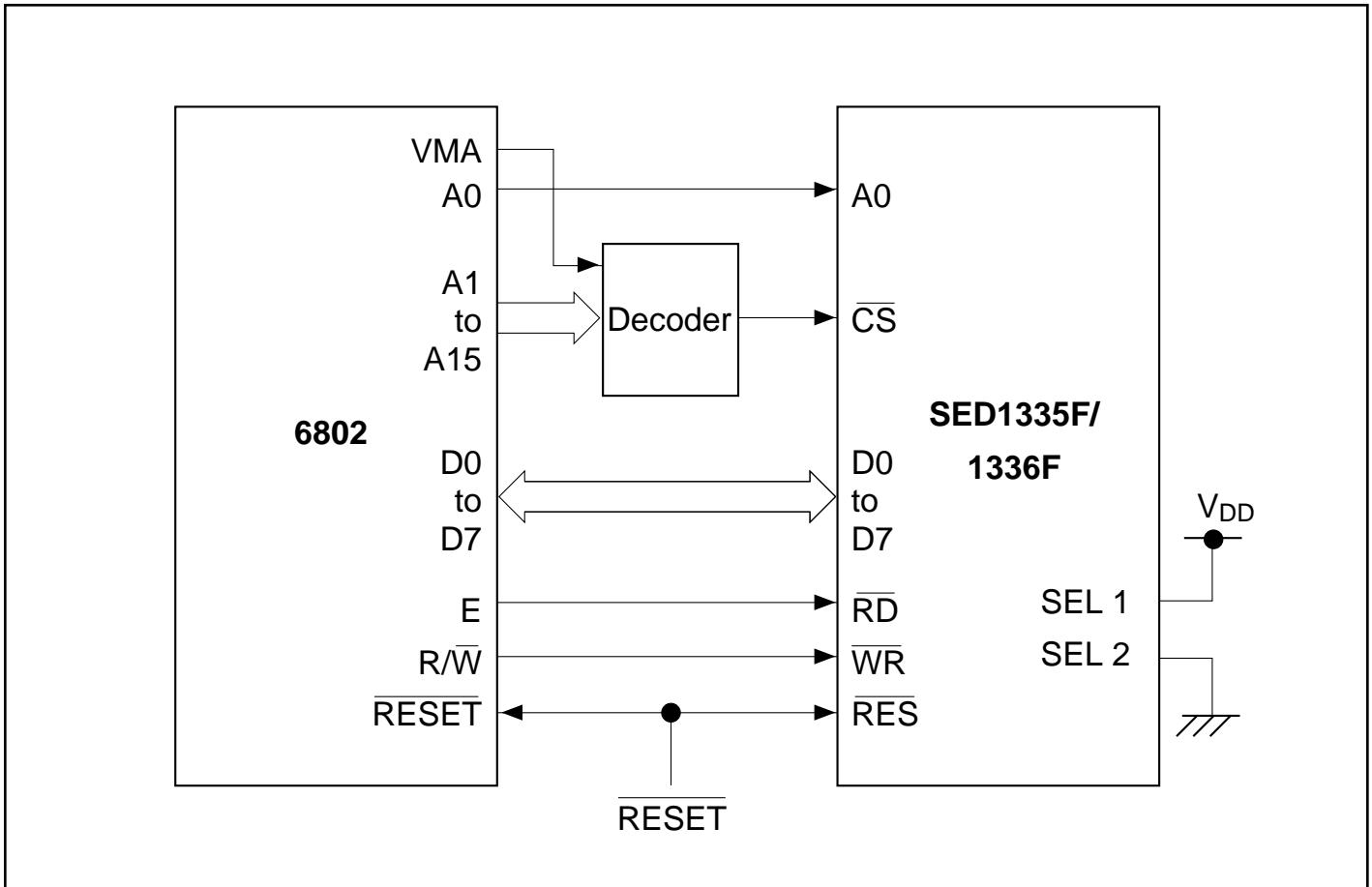

Figure 73. 6802 to SED1330F/1335F/1336F interface

**Note:** \*For SED1336F: SEL 2 is open..

## 8.2 Display Memory Interface

### 8.2.1 Static RAM

The figure below shows the interface between an 8K × 8 static RAM and the SED1330F/1335F/1336F.

Note that bus buffers are required if the bus is heavily loaded.

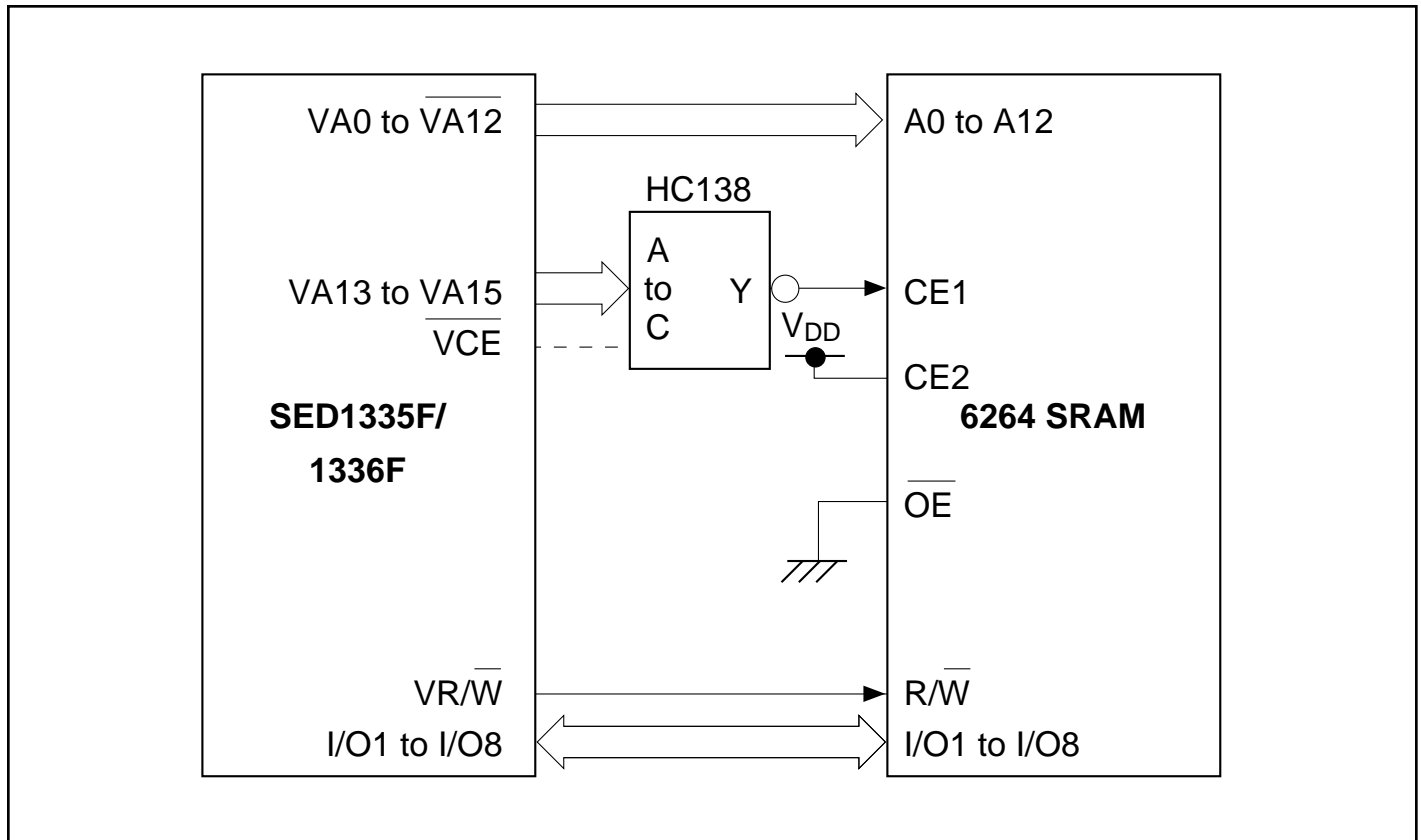

Figure 74. Static RAM interface

### 8.2.2 Supply Current during Display Memory Access

The 24 address and data lines of the SED1330F/1335F/1336F cycle at one-third of the oscillator frequency,  $f_{OSC}$ . The charge and discharge current on these pins,  $I_{VOP}$ , is given by the equation below. When  $I_{VOP}$  exceeds  $I_{OPR}$ , it can be estimated by:

$$I_{VOP} \propto C V f$$

where C is the capacitance of the display memory bus, V is the operating voltage, and f is the operating frequency.

If  $V_{OPR} = 5.0V$ ,  $f = 1.0 \text{ MHz}$ , and the display memory bus capacitance is  $1.0 \text{ pF}$  per line:

$$I_{VOP} \leq 120 \mu\text{A} / \text{MHz} \times \text{pF}$$

To reduce current flow during display memory accesses, it is important to use low-power memory, and to minimize both the number of devices and the parasitic capacitance.

8.3 Oscillator Circuit

The SED1330F/1335F/1336F incorporates an oscillator circuit. A stable oscillator can be constructed simply by connecting an AT-cut crystal and two capacitors to OSC1 and OSC2, as shown in the figure below. If the oscillator frequency is increased,  $C_D$  and  $C_G$  should be decreased proportionally.

Note that the circuit board lines to OSC1 and OSC2 must be as short as possible to prevent wiring capacitance from changing the oscillator frequency or increasing the power consumption.

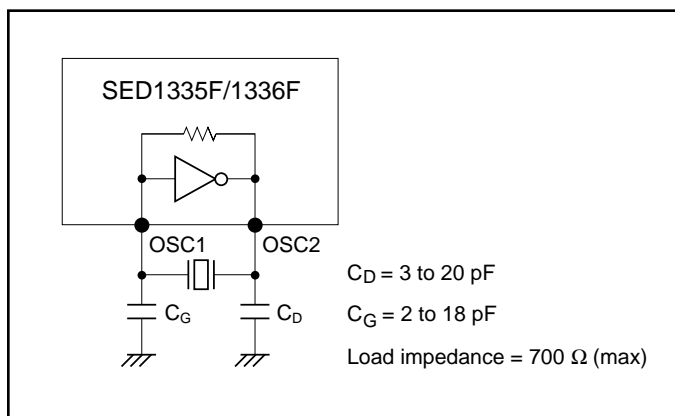

Figure 75. Crystal oscillator

8.4 Status Flag

The SED1330F/1335F/1336F has a single bit status flag.

D6: X line standby

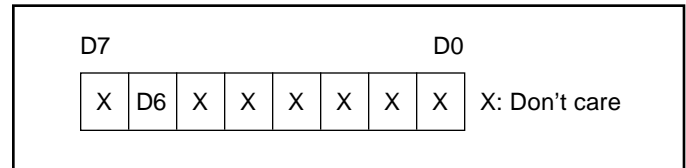

Figure 76. Status flag

The D6 status flag is LOW (0) for the TC/R - C/R cycles at the end of each line where the SED1330F/1335F/1336F is not reading the display memory. The micro-processor may use this period to update display memory without affecting the display; however, it is recommended that the display be turned off when refreshing the whole display.

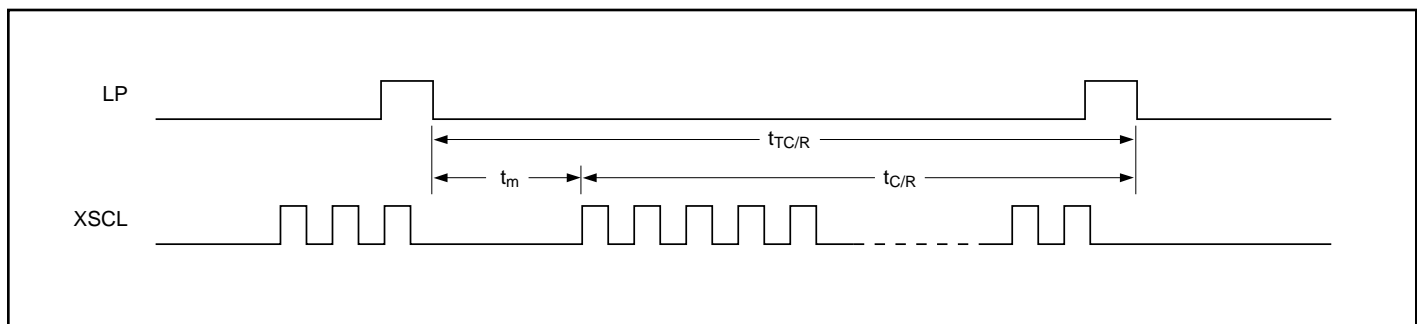

Figure 77. C/R to TC/R time difference

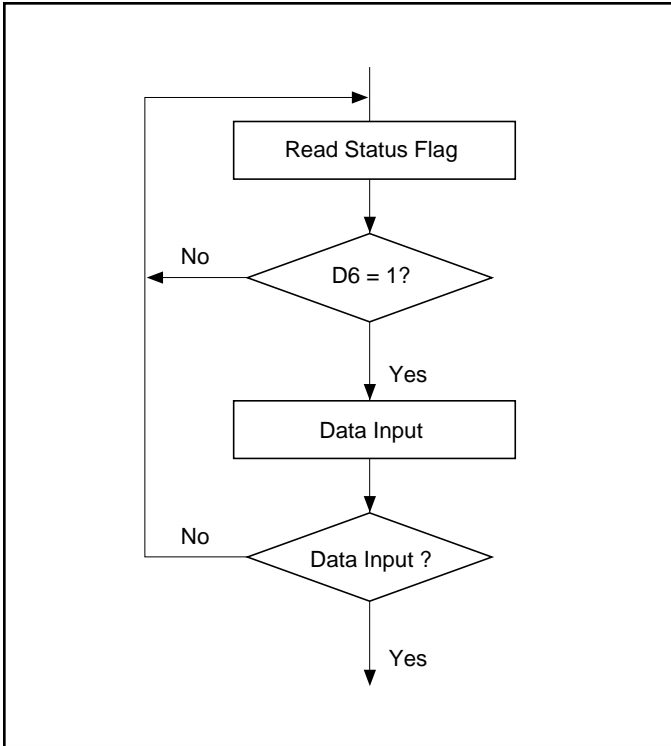

Figure 78. Flowchart for busy flag checking

8.5 Reset

The SED1330F requires a reset pulse at least 1 ms long after power-on in order to re-initialize its internal state. The SED1335F/1336F requires a minimum reset pulse of 200µs.

During reset, the LCD drive signals XD, LP and FR are halted.

For maximum reliability, it is not recommended to apply a DC voltage to the LCD panel while the SED1330F/1335F/1336F is reset. Turn off the LCD power supplies for at least one frame period after the start of the reset pulse.

The SED1330F/1335F/1336F cannot receive commands while it is reset. Commands to initialize the internal registers should be issued soon after a reset.

A delay of 3 ms (maximum) is required following the rising edges of both RES and V<sub>DD</sub> to allow for system stabilization.

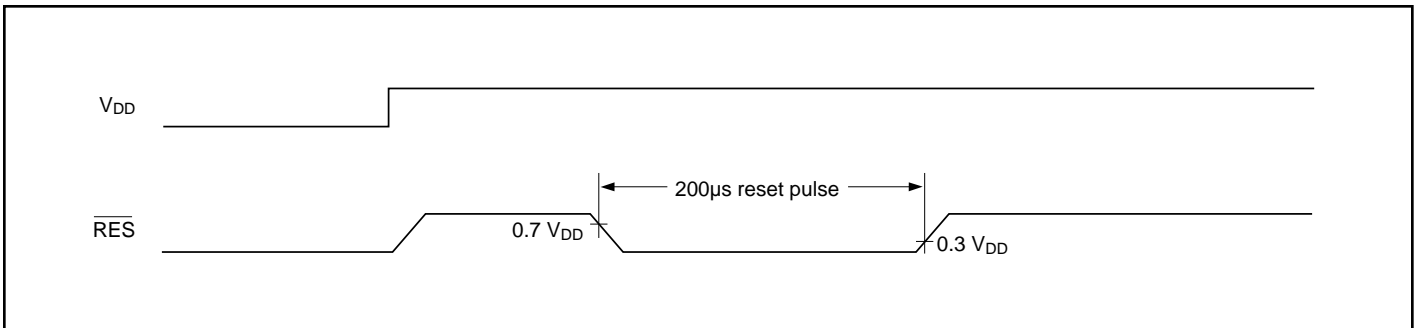

Figure 79. Reset timing

**THIS PAGE INTENTIONALLY BLANK**

# **9.0**

## ***Application Notes***

**THIS PAGE INTENTIONALLY BLANK**



9.0 Application Notes

9.1 Initialization Parameters

The parameters for the initialization commands must be determined first. Square brackets around a parameter name indicate the number represented by the parameter, rather than the value written to the parameter register. For example, [FX] = FX + 1.

9.1.1 SYSTEM SET Instruction and Parameters

• FX

The horizontal character field size is determined from the horizontal display size in pixels [VD] and the number of characters per line [VC].

$$[VD] / [VC] \leq [FX]$$

VD: # of X-directional dots

VC: # of X-directional characters

• C/R

C/R can be determined from VC and FX.

$$[C/R] = \text{RND}([FX] / 8) \times [VC]$$

where RND(x) denotes x rounded up to the next highest integer. [C/R] is the number of bytes per line, not the number of characters.

• TC/R

TC/R must satisfy the condition  $[TC/R] \geq [C/R] + 4$ .

• f<sub>OSC</sub> and f<sub>FR</sub>

Once TC/R has been set, the frame frequency, f<sub>FR</sub>, and lines per frame [L/F] will also have been set. The lower limit on the oscillator frequency f<sub>OSC</sub> is given by:

$$f_{OSC} \geq ([TC/R] \times 9 + 1) \times [L/F] \times f_{FR}$$

- If no standard crystal close to the calculated value of f<sub>OSC</sub> exists, a higher frequency crystal can be used and the value of TC/R revised using the above equation.
- Symptoms of an incorrect TC/R setting are listed below. If any of these appears, check the value of TC/R and modify it if necessary.
  - Vertical scanning halts and a high-contrast horizontal line appears.
  - All pixels are on or off.
  - The LP output signal is absent or corrupted.
  - The display is unstable.

Table 31. Epson LCD unit example parameters (SED1335F only)

Resolution (X × Y)	[FX]	[FY]	[C/R]	TC/R	f <sub>osc</sub> (MHz) See Note 2
256 × 64	[FX] = 6 pixels: 256 / 6 = 42 remainder 4 = 4 blank pixels	8 or 16, depending on the screen	[C/R] = 42 = 2AH bytes: C/R = 29H. When using HDOT SCR, [C/R] = 43 bytes	2DH	1.85
512 × 64	[FX] = 6 pixels: 512 / 6 = 85 remainder 2 = 2 blank pixels	8 or 16, depending on the screen	[C/R] = 85 = 55H bytes: C/R = 54H. When using HDOT SCR, [C/R] = 86 bytes	58H	3.59
256 × 128	[FX] = 8 pixels: 256 / 8 = 32 remainder 0 = no blank pixels	8 or 16, depending on the screen	[C/R] = 32 = 20H bytes: C/R = 19H. When using HDOT SCR, [C/R] = 33 bytes	22H	2.90
512 × 128	[FX] = 10 pixels: 512 / 10 = 51 remainder 2 = 2 blank pixels	8 or 16, depending on the screen	[C/R] = 102 = 66H bytes: C/R = 65H. When using HDOT SCR, [C/R] = 103 bytes	69H	8.55

Notes:

1. The remainder pixels on the right-hand side of the display are automatically blanked by the SED1335F. There is no need to zero the display memory corresponding to these pixels.
2. Assuming a frame frequency of 60 Hz.

9.1.2 Initialization Example

The initialization example shown in Figure 80 is for a SED1330F/1335F/1336F with an 8-bit microproces-

sor interface bus display unit (512 × 128 pixels).

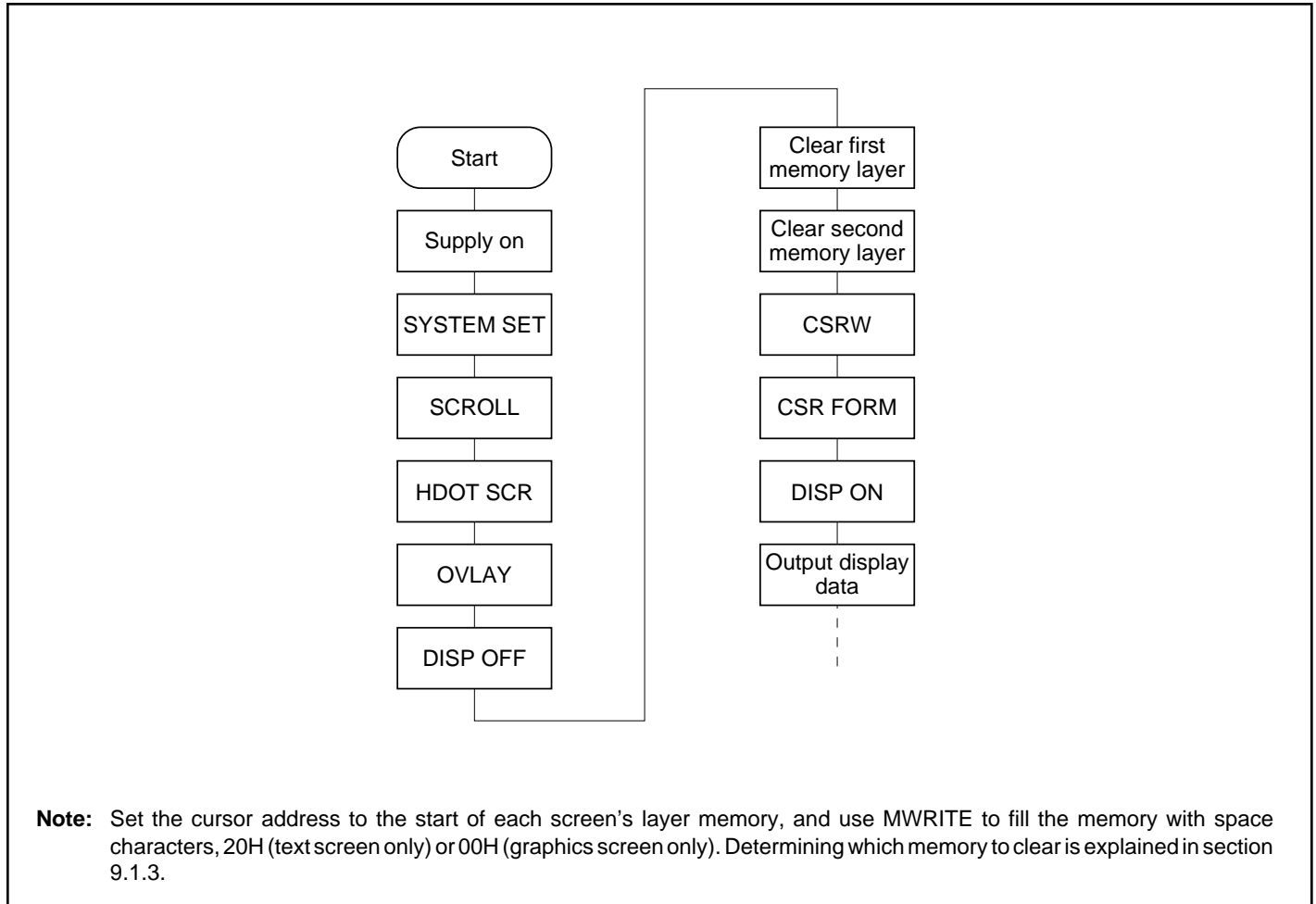

Figure 80. Initialization procedure

Table 32. Initialization procedure

No.	Command	Operation
1	Power-up	
2	Supply	Wait for at least 3 ms after reset with VDD ≥ 4.5V
3	SYSTEM SET C = 40H P1 = 38H  P2 = 87H  P3 = 07H P4 = 3FH P5 = 49H  P6 = 7FH P7 = 80H P8 = 00H	initialization.  M0: Internal CG ROM M1: CG RAM is 32 characters maximum M2: 8 lines per character W/S: Two-panel drive IV: No top-line compensation FX: Horizontal character size = 8 pixels WF: Two-frame AC drive FY: Vertical character size = 8 pixels C/R: 64 display addresses per line TC/R: Total address range per line = 90 fOSC = 6.0 MHz, fFR = 70 Hz L/F: 128 display lines AP: Virtual screen horizontal size is 128 addresses
4	SCROLL C = 44H P1 = 00H P2 = 00H P3 = 40H P4 = 00H P5 = 10H P6 = 40H P7 = 00H P8 = 04H	First screen block start address Set to 0000H Display lines in first screen block = 64 Second screen block start address Set to 1000H Display lines in second screen block = 64 Third screen block start address Set to 0400H

(continued)

Table 32. Initialization procedure (continued)

No.	Command	Operation
	P9 = 00H P10 = 30H	Fourth screen block start address Set to 3000H  <div style="text-align: center;"> <p>Display memory</p> </div>
5	HDOT SCR C = 5AH P1 = 00H	Set horizontal pixel shift to zero
6	OVLAY C = 5BH P1 = 01H	MX 1, MX 0: Inverse video superposition DM 1: First screen block is text mode DM 2: Third screen block is text mode
7	DISP ON/OFF C = 58H P1 = 56H	D: Display OFF FC1, FC0: Flash cursor at 2 Hz FP1, FP0: First screen block ON FP3, FP2: Second and fourth screen blocks ON FP5, FP4: Third screen block ON
8	Clear data in first layer	Fill first screen layer memory with 20H (space character)

(continued)

Table 32. Initialization procedure (continued)

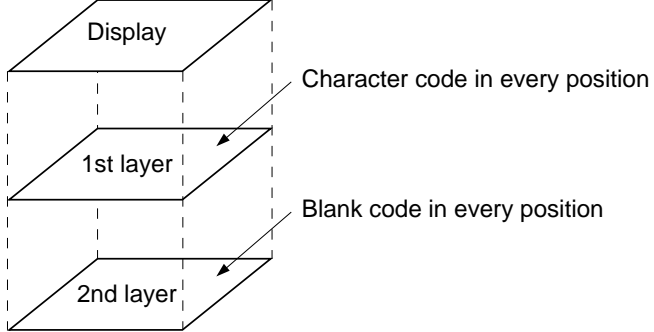
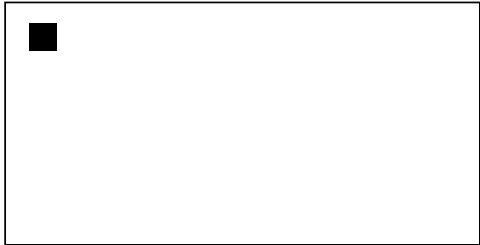
No.	Command	Operation
9	Clear data in second layer	Fill second screen layer memory with 00H (blank data)  
10	CSRW C = 46H P1 = 00H P2 = 00H	Set cursor to start of first screen block
11	CSR FORM C = 5DH P1 = 04H P2 = 86H	CRX: Horizontal cursor size = 5 pixels CRY: Vertical cursor size = 7 pixels CM: Block cursor
12	DISP ON/OFF C = 59H	Display ON  
13	CSR DIR C = 4CH	Set cursor shift direction to right

(continued)

Table 32. Initialization procedure (continued)

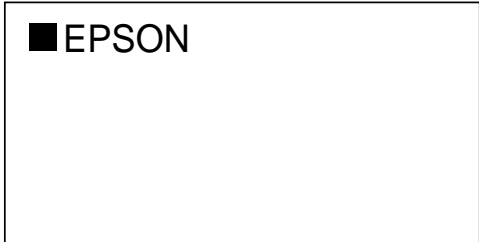
No.	Command	Operation
14	MWRITE C = 42H P1 = 20H P2 = 45H P3 = 50H P4 = 53H P5 = 4FH P6 = 4EH	‘ ‘ ‘E’ ‘P’ ‘S’ ‘O’ ‘N’ 
15	CSRW C = 46H P1 = 00H P2 = 10H	Set cursor to start of second screen block
16	CSR DIR C = 4FH	Set cursor shift direction to down
17	MWRITE C = 42H P1 = FFH ↓ P9 = FFH	Fill in a square to the left of the ‘E’ 
18	CSRW C = 46H P1 = 01H P2 = 10H	Set cursor address to 1001H
19	MWRITE C = 42H	

(continued)

Table 32. Initialization procedure (continued)

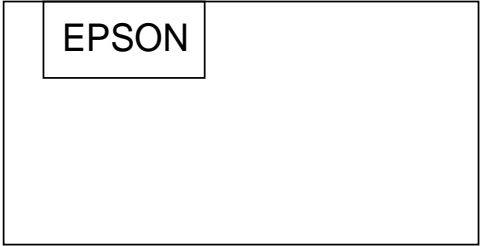
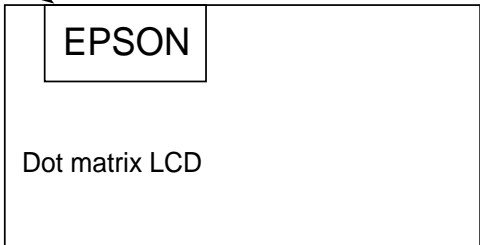
No.	Command	Operation
	P1 = FFH ↓ P9 = FFH CSRW	Fill in the second screen block in the second column of line 1  Repeat operations 18 and 19 to fill in the background under 'EPSON'
20  ↓	CSRW	Inverse display 
29     30	MWRITE    CSRW C = 46H P1 = 00H	Set cursor to line three of the first screen block
31	P2 = 01H CSR DIR C = 4CH	Set cursor shift direction to right
32	MWRITE C = 42H P1 = 44H P2 = 6FH P3 = 74H P4 = 20H P5 = 4DH P6 = 61H P7 = 74H P8 = 72H P9 = 69H P10 = 78H P11 = 20H P12 = 4CH P13 = 43H P14 = 44H	'D' 'o' 't' ',' Inverse display 'M' 'a' 't' 'r' 'i' 'x' ',' 'L' 'C' 'D' 

9.1.3 Display Mode Setting Example 1: Combining Text and Graphics

• Conditions

- 320 × 200 pixels, single-panel drive (1/200 duty cycle)
- First layer: text display
- Second layer: graphics display
- 8 × 8-pixel character font
- CG RAM not required

• Display memory allocation

- First layer (text): 320/8 = 40 characters per line, 200/8 = 25 lines. Required memory size = 40 × 25 = 1000 bytes.
- Second layer (graphics): 320/8 = 40 characters per line, 200/1 = 200 lines. Required memory size = 40 × 200 = 8000 bytes.

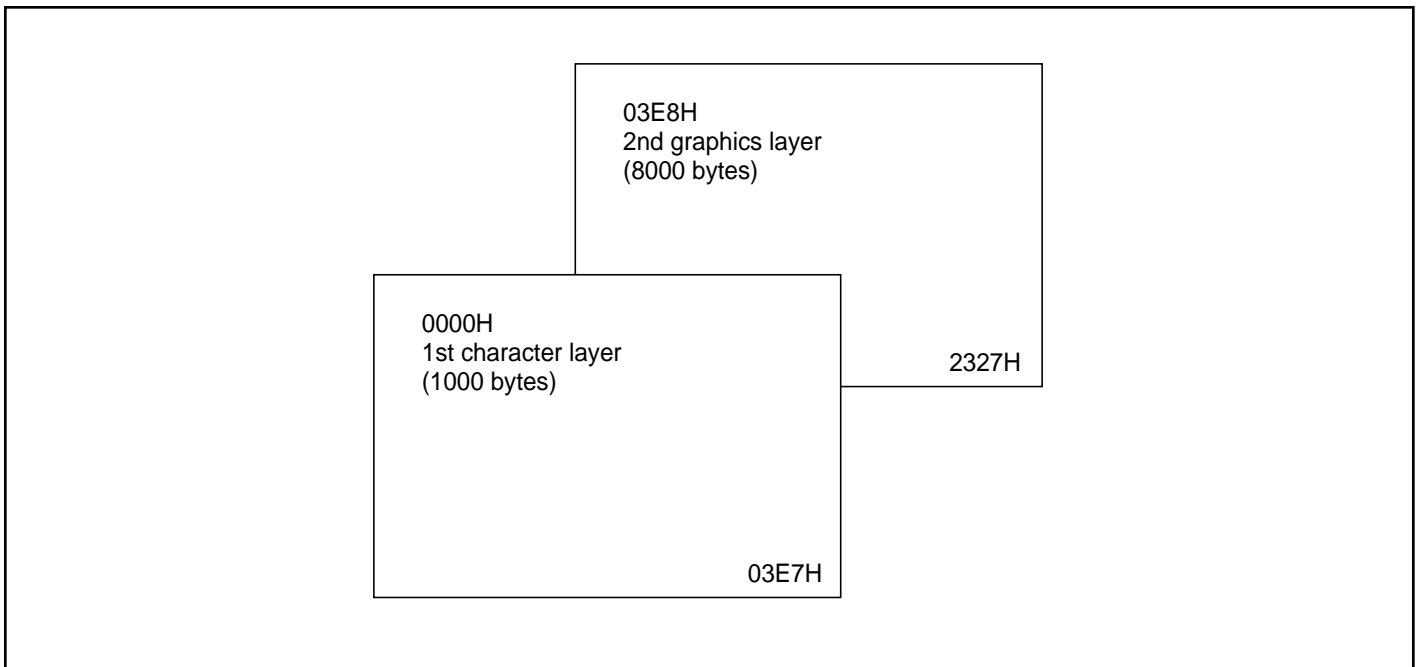

Figure 81. Character over graphics layers

• Register setup procedure

SYSTEM SET	TC/R calculation	SCROLL
C = 40H		C = 44H
P1 = 30H	$f_{OSC} = 6 \text{ MHz}$	P1 = 00H
P2 = 87H	$f_{FR} = 70 \text{ Hz}$	P2 = 00H
P3 = 07H		P3 = C8H
P4 = 27H	$(1/6) \times 9 \times [TC/R] \times 200 = 1/70$	P4 = E8H
P5 = 2FH	$[TC/R] = 48, \text{ so } TC/R = 2FH$	P5 = 03H
P6 = C7H		P6 = C8H
P7 = 28H		P7 = XH
P8 = 00H		P8 = XH
		P9 = XH
		P10 = XH



CSR FORM

C = 5DH  
 P1 = 04H  
 P2 = 86H

HDOT SCR

C = 5AH  
 P1 = 00H

OVLAY

C = 5BH  
 P1 = 00H

DISP ON/OFF

C = 59H  
 P1 = 16H

X = Don't care

9.1.4 Display Mode Setting Example 2: Combining Graphics and Graphics

• Conditions

- 320 × 200 pixels, single-panel drive (1/200 duty cycle)
- First layer: graphics display
- Second layer: graphics display

• Display memory allocation

- First layer (graphics): 320/8 = 40 characters per line, 200/1 = 200 lines. Required memory size = 40 × 200 = 8000 bytes.
- Second layer (graphics): 320/8 = 40 characters per line, 200/1 = 200 lines. Required memory size = 8000 bytes.

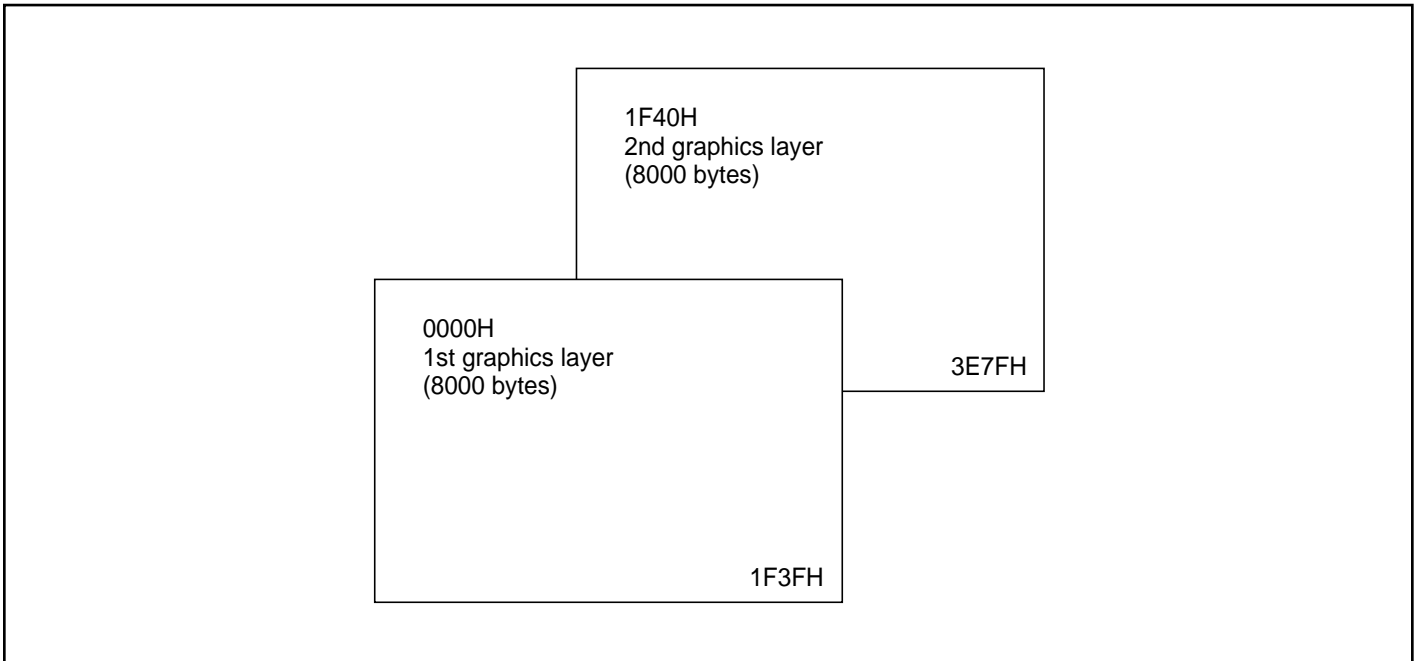

Figure 82. Two-layer graphics

• Register setup procedure

SYSTEM SET      TC/R calculation

C =      40H

P1 =      30H       $f_{OSC} = 6 \text{ MHz}$

P2 =      87H       $f_{FR} = 70 \text{ Hz}$

P3 =      07H

P4 =      27H       $(1/6) \times 9 \times [TC/R] \times 200 = 1/70$

P5 =      2FH       $[TC/R] = 48, \text{ so } TC/R = 2FH$

P6 =      C7H

P7 =      28H

P8 =      00H

SCROLL

C =      44H

P1 =      00H

P2 =      00H

P3 =      C8H

P4 =      40H

P5 =      1FH

P6 =      C8H

P7 =      XH

P8 =      XH

P9 =      XH

P10 =      XH

CSR FORM

C =      5DH

P1 =      07H

P2 =      87H

HDOT SCR

C =      5AH

P1 =      00H

OVLAY

C =      5BH

P1 =      0CH

DISP ON/OFF

C =      59H

P1 =      16H

X = Don't care

9.1.5 Display Mode Setting Example 3: Combining Three Graphics Layers

• Conditions

- 320 × 200 pixels, single-panel drive (1/200 duty cycle)
- First layer: graphics display
- Second layer: graphics display
- Third layer: graphics display

• Display memory allocation

- All layers (graphics):  $320/8 = 40$  characters per line,  $200/1 = 200$  lines. Required memory size =  $40 \times 200 = 8000$  bytes.

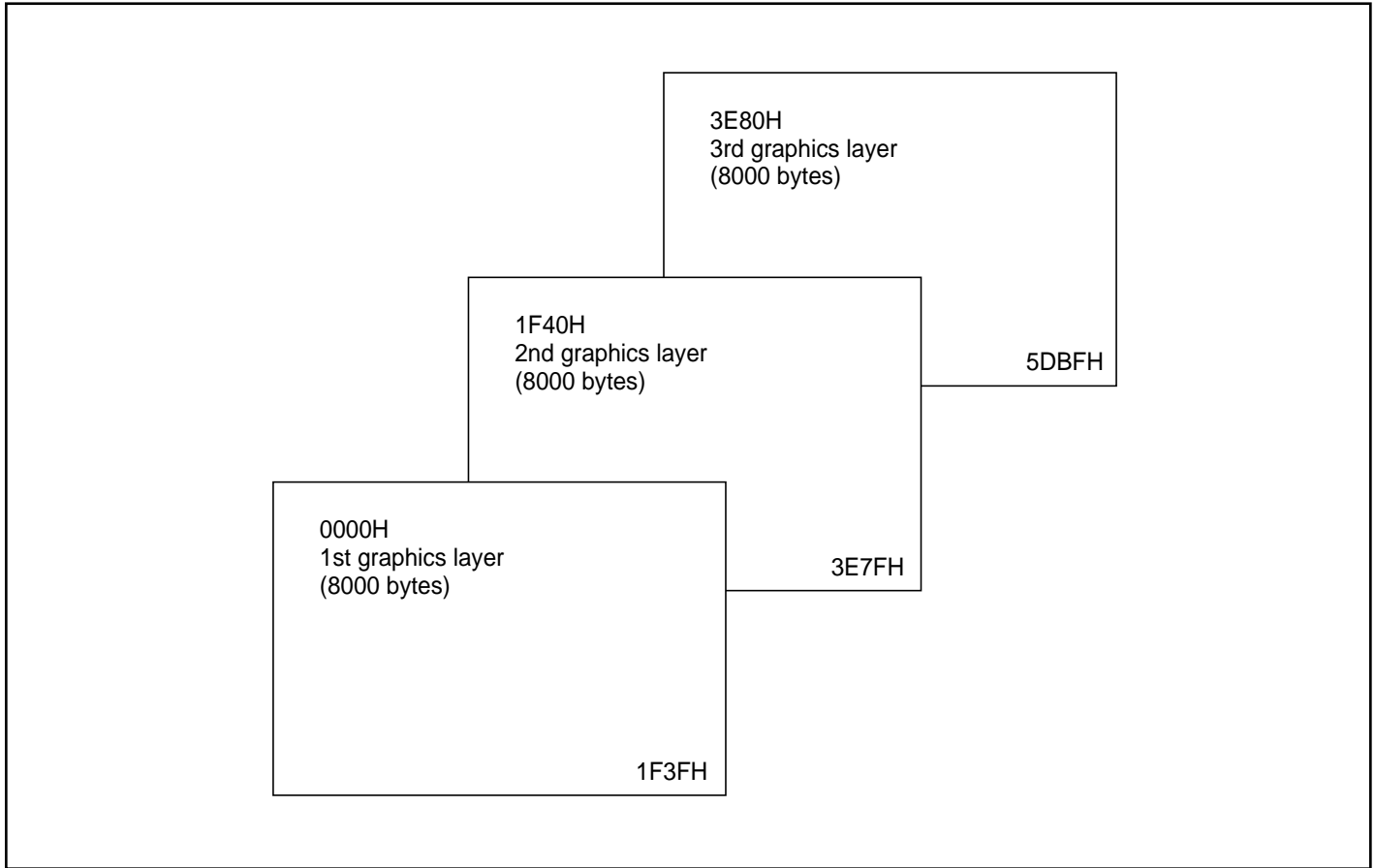

Figure 83. Three-layer graphics

• Register setup procedure

SYSTEM SET	TC/R calculation	SCROLL
C = 40H		C = 44H
P1 = 30H	$f_{OSC} = 6 \text{ MHz}$	P1 = 00H
P2 = 87H	$f_{FR} = 70 \text{ Hz}$	P2 = 00H
P3 = 07H		P3 = C8H
P4 = 27H	$(1/6) \times 9 \times [TC/R] \times 200 = 1/70$	P4 = 40H
P5 = 2FH	$[TC/R] = 48, \text{ so } TC/R = 2FH$	P5 = 1FH
P6 = C7H		P6 = C8H
P7 = 28H		P7 = 80H
P8 = 00H		P8 = 3EH
		P9 = XH
		P10 = XH

CSR FORM

C = 5DH  
 P1 = 07H  
 P2 = 87H

HDOT SCR

C = 5AH  
 P1 = 00H

OVLAY

C = 5BH  
 P1 = 1CH

DISP ON/OFF

C = 59H  
 P1 = 16H

X = Don't care

9.2 System Overview

Figure 84 shows the SED1330F/1335F/1336F in a typical system. The microprocessor issues instructions to the 1330F/SED1335F/1336F, and the SED1330F/1335F/1336F drives the LCD panel and may have up to 64Kbytes of display memory.

Since all of the LCD control circuits are integrated onto the SED1330F/1335F/1336F, few external components are required to construct a complete medium-resolution liquid crystal display.

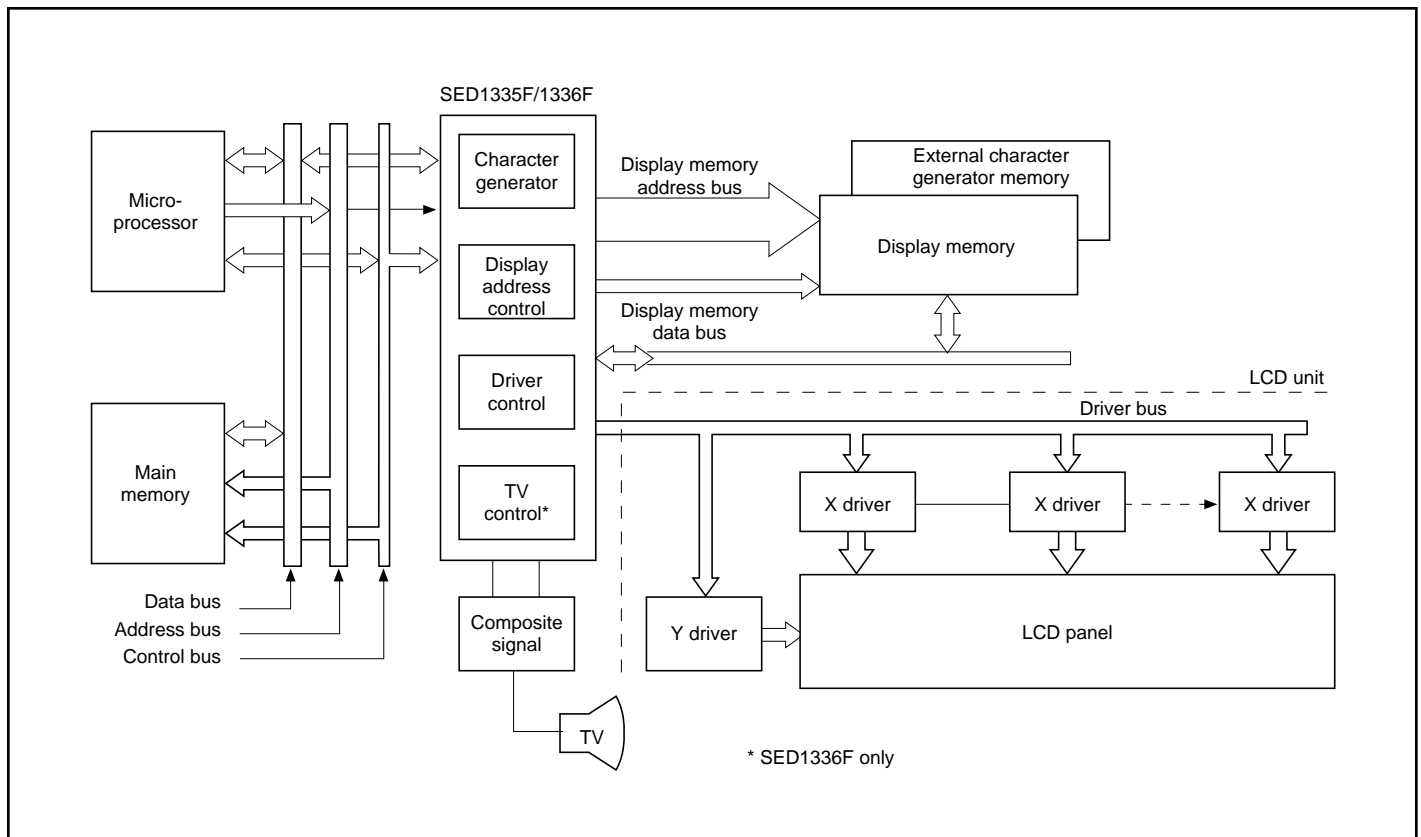

Figure 84. System block diagram

9.3 System Interconnection

9.3.1 SED1330F/1335F

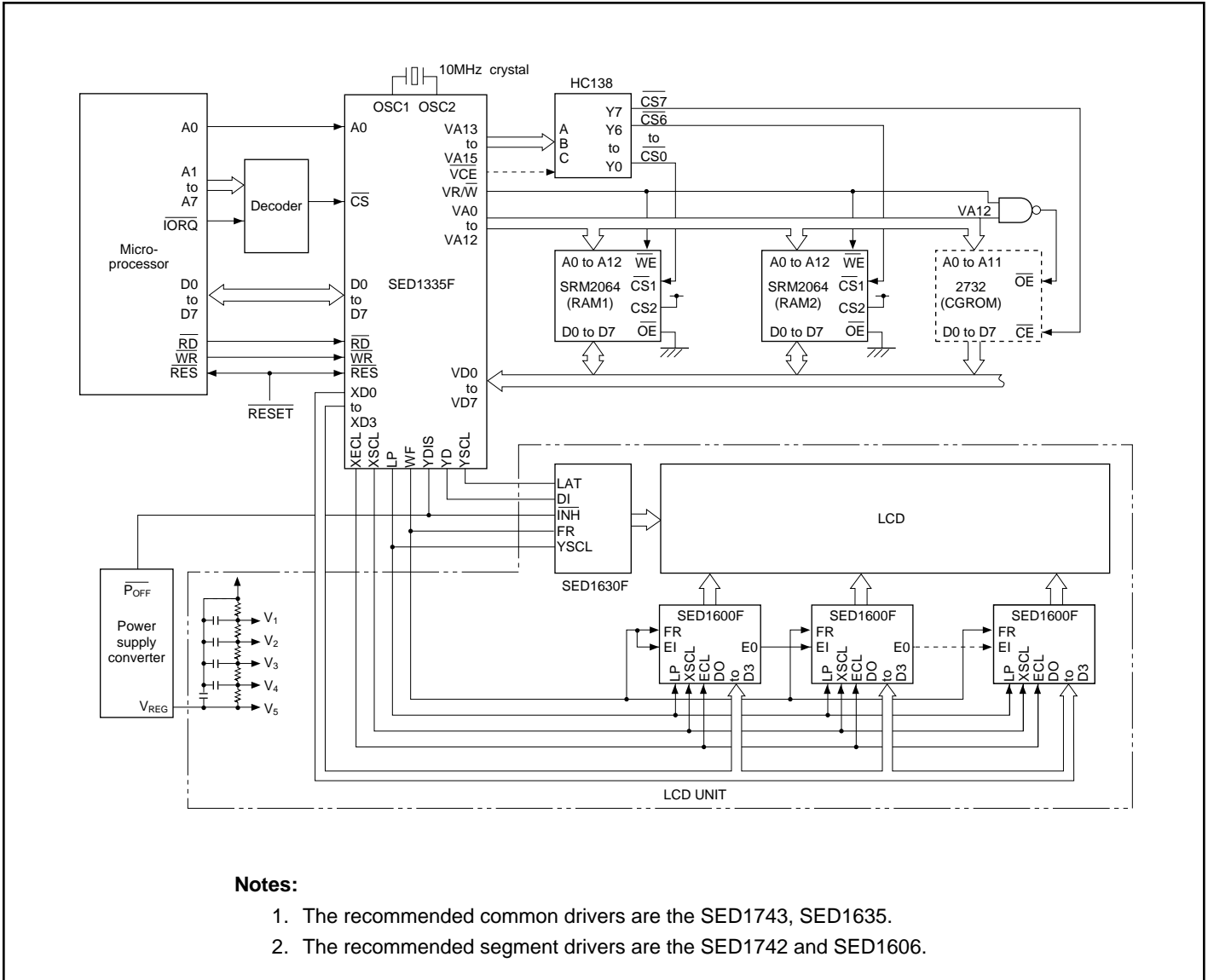

Figure 85. System interconnection diagram

9.3.2 SED1336F

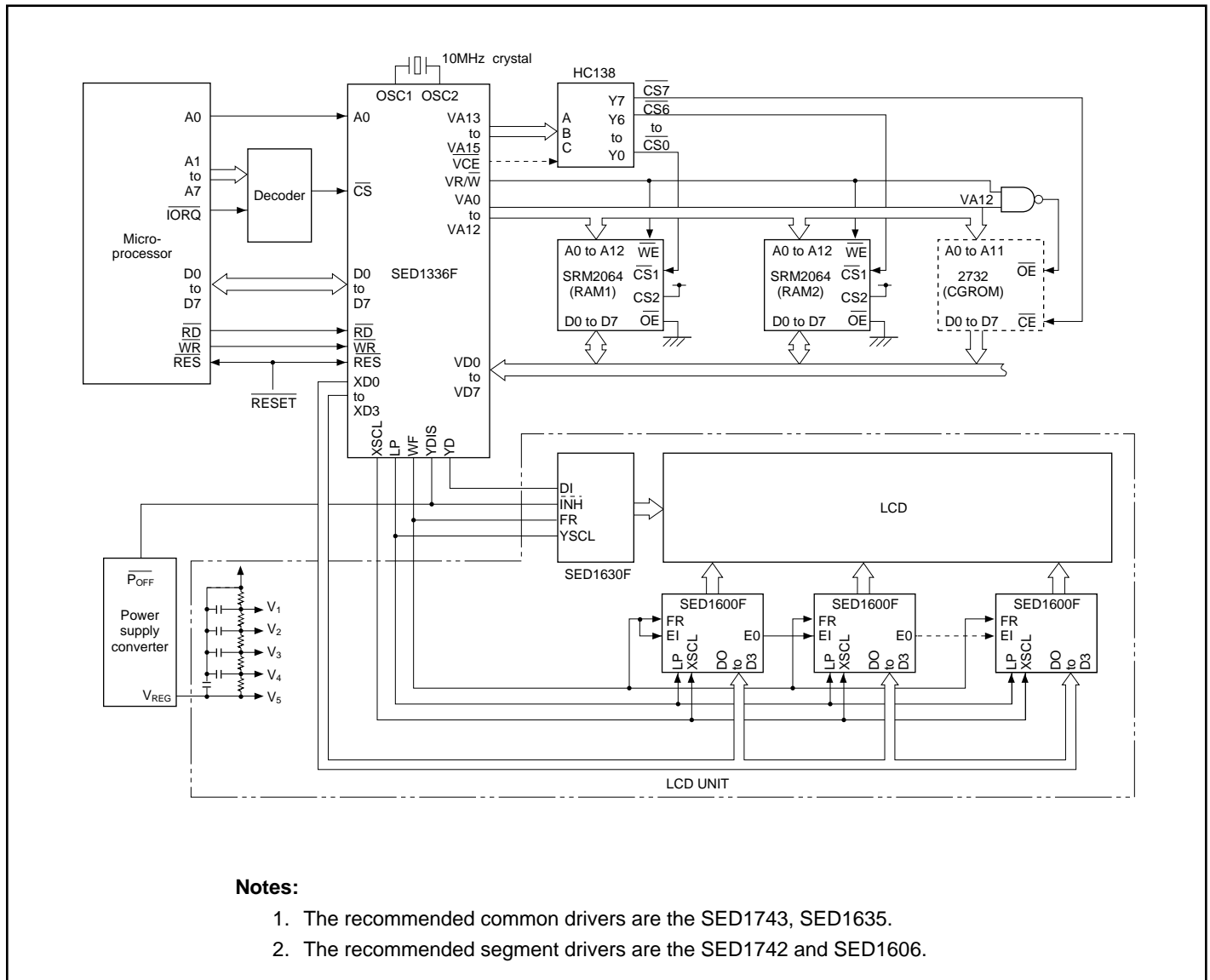

Figure 86. System interconnection diagram

The SED1330F/1335F/1336F's layered screens and flexible scrolling facilities support a range of display functions and reduces the load on the controlling microprocessor when displaying underlining, inverse display, text overlaid on graphics or simple animation.

These facilities are supported by the SED1330F/1335F/1336F's ability to divide display memory into up to four different areas.

• **Character code table**

- Contains character codes for text display
- Each character requires 8 bits
- Table mapping can be changed by using the scroll start function

- **Graphics data table**
  - Contains graphics bitmaps
  - Word length is 8 bits
  - Table mapping can be changed
  
- **CG RAM table**
  - Character generator memory can be modified by the external microprocessor
  - Character sizes up to  $8 \times 16$  pixels (16 bytes per character)
  - Maximum of 64 characters
  - Table mapping can be changed
  
- **CG ROM table**
  - Used when the internal character generator is not adequate
  - Can be used in conjunction with the internal character generator and external character generator RAM
  - Character sizes up to  $8 \times 16$ -pixels (16 bytes per character)
  - Maximum of 256 characters
  - Fixed mapping at F000H to FFFFH

## 9.4 Smooth Horizontal Scrolling

Figure 87 illustrates smooth display scrolling to the left. When scrolling left, the screen is effectively moving to the right, over the larger virtual screen.

Instead of changing the display start address SAD and shifting the display by eight pixels, smooth scrolling is achieved by repeatedly changing the pixel-shift parameter of the HDOT SCR command. When the display has been scrolled seven pixels, the HDOT SCR pixel-shift parameter is reset to zero and SAD incremented by one. Repeating this operation at a suitable rate gives the appearance of smooth scrolling.

To scroll the display to the right, the reverse procedure is followed.

When the edge of the virtual screen is reached, the microprocessor must take appropriate steps so that the display is not corrupted. The scroll must be stopped or the display modified.

Note that the HDOT SCR command cannot be used to scroll individual layers.

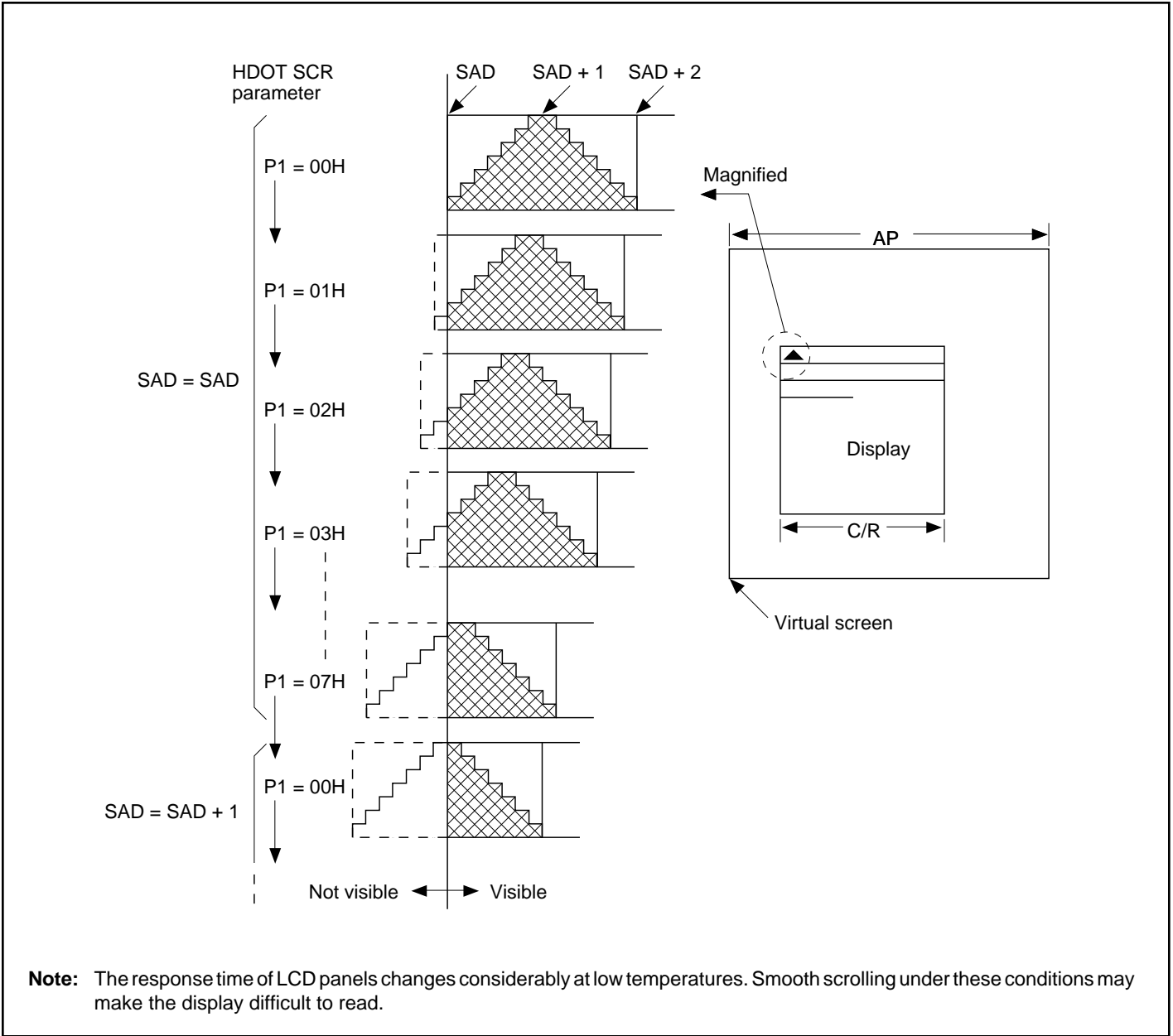

Figure 87. HDOT SCR example



9.5 Layered Display Attributes

SED1330F/1335F/1336F incorporates a number of functions for enhanced displays using monochrome LCD panels. It allows the display of inverse characters, half-intensity menu pads and flashing of selected screen areas. These functions are controlled by the OVLAY and DISP ON/OFF commands.

A number of means can be used to achieve these effects, depending on the display configuration. These are listed below. Note, however, that not all of these can be used in the one layer at the same time.









Attribute	MX1	MX0	Combined layer display	1st layer display	2ndt layer display
Reverse	0	1	IV 	IV EPSON	
	1	1			
Half-tone	0	0	ME 	ME Yes, No	
	1	1			
Local flashing	0	0	BL 	BL	
	0	1			
Ruled line	0	0	RL 	RL LINE LINE	
	0	1			
	1	1			

Figure 88. Layer synthesis

9.5.1 Inverse Display

The first layer is text, the second layer is graphics.

1. CSRW, CSDIR, MWRITE  
Write 1s into the graphics screen at the area to be inverted.
2. OVLAY: MX0 = 1, MX1 = 0  
Set the combination of the two layers to Exclusive-OR.
3. DISP ON/OFF: FP0 = FP1 = 1, FP1 = FP3 = 0.  
Turn on layers 1 and 2.

9.5.2 Half-tone Display

The FP parameter can be used to generate half-intensity display by flashing the display at 17 Hz. Note that this mode of operation may cause flicker problems with certain LCD panels.

9.5.2.1 Menu Pad Display

Turn flashing off for the first layer, on at 17 Hz for the second layer, and combine the screens using the OR function.

1. OVLAY: P1 = 00H
2. DISP ON/OFF: P1 = 34H

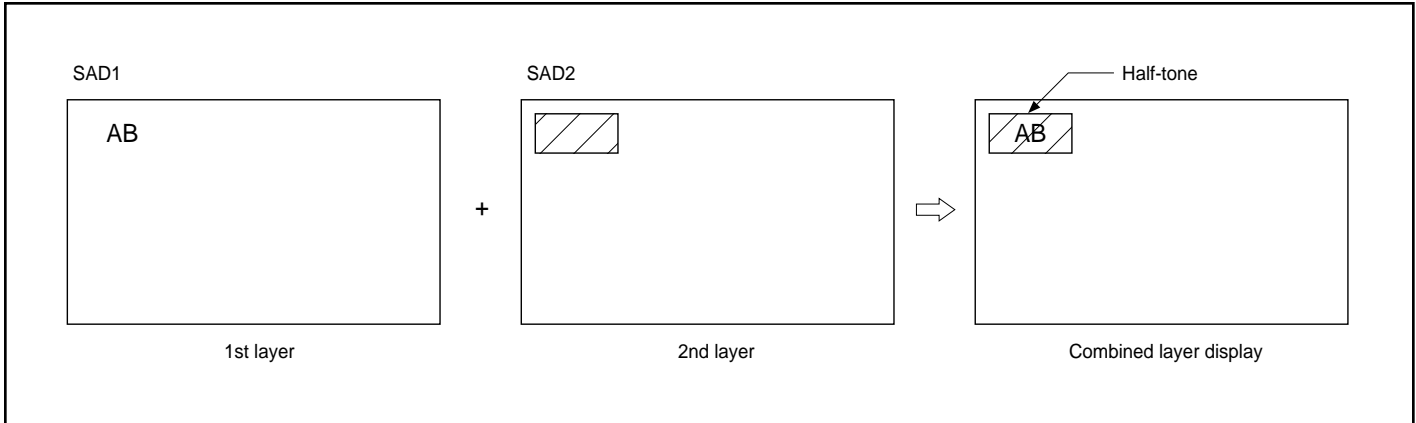

Figure 89. Half-tone character and graphics

**9.5.2.2 Graph Display**

To present two overlaid graphs on the screen, configure the display as for the menu bar display and put one graph on each screen layer. The difference in contrast between the half- and full-intensity displays will make it easy to distinguish between the two graphs and help create an attractive display.

1. OVLAY: P1 = 00H
2. DISP ON/OFF: P1 = 34H

**9.5.3 Flashing Areas**

**9.5.3.1 Small Area**

To flash selected characters, the MPU can alternately write the characters as character codes and blank characters at intervals of 0.5 to 1.0 seconds.

**9.5.3.2 Large Area**

Divide both layer 1 and layer 2 into two screen blocks each, layer 2 being divided into the area to be flashed and the remainder of the screen. Flash the layer 2 screen block at 2 Hz for the area to be flashed and combine the layers using the OR function.

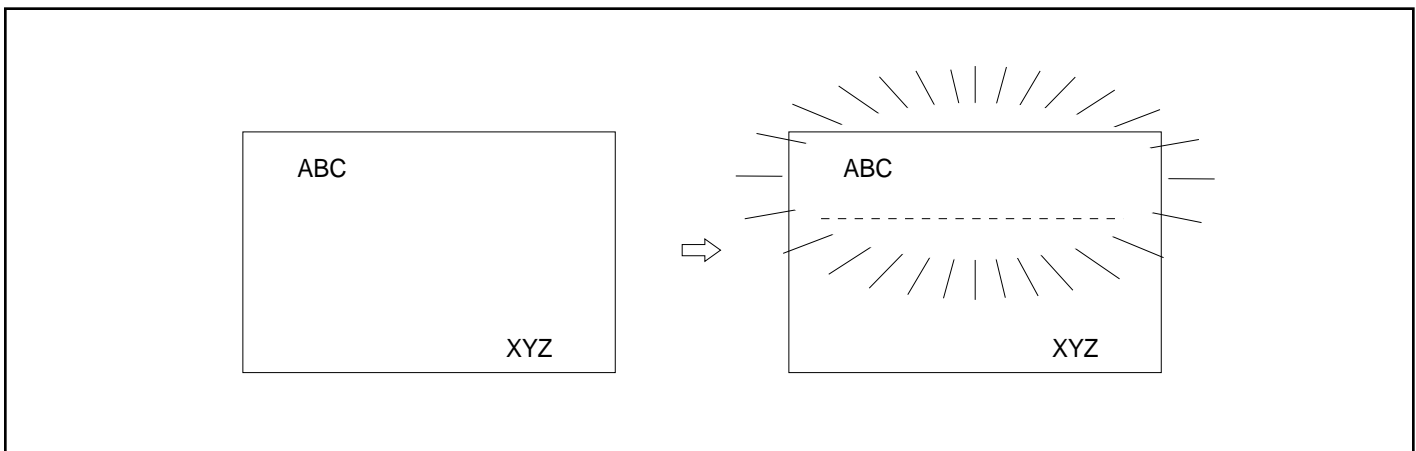

Figure 90. Localized flashing

9.6 16 × 16-dot Graphic Display

9.6.1 Command Usage

This example shows how to display 16 × 16-pixel characters. The command sequence is as follows:

- CSRW Set the cursor address.
- CSRDIR Set the cursor auto-increment direction.
- MWRITE Write to the display memory.

9.6.2 Kanji Character Display

The program for writing large characters operates as follows:

1. The microprocessor reads the character data from its ROM.
2. The microprocessor sets the display address and writes to the VRAM. The flowchart is shown in Figure 91.

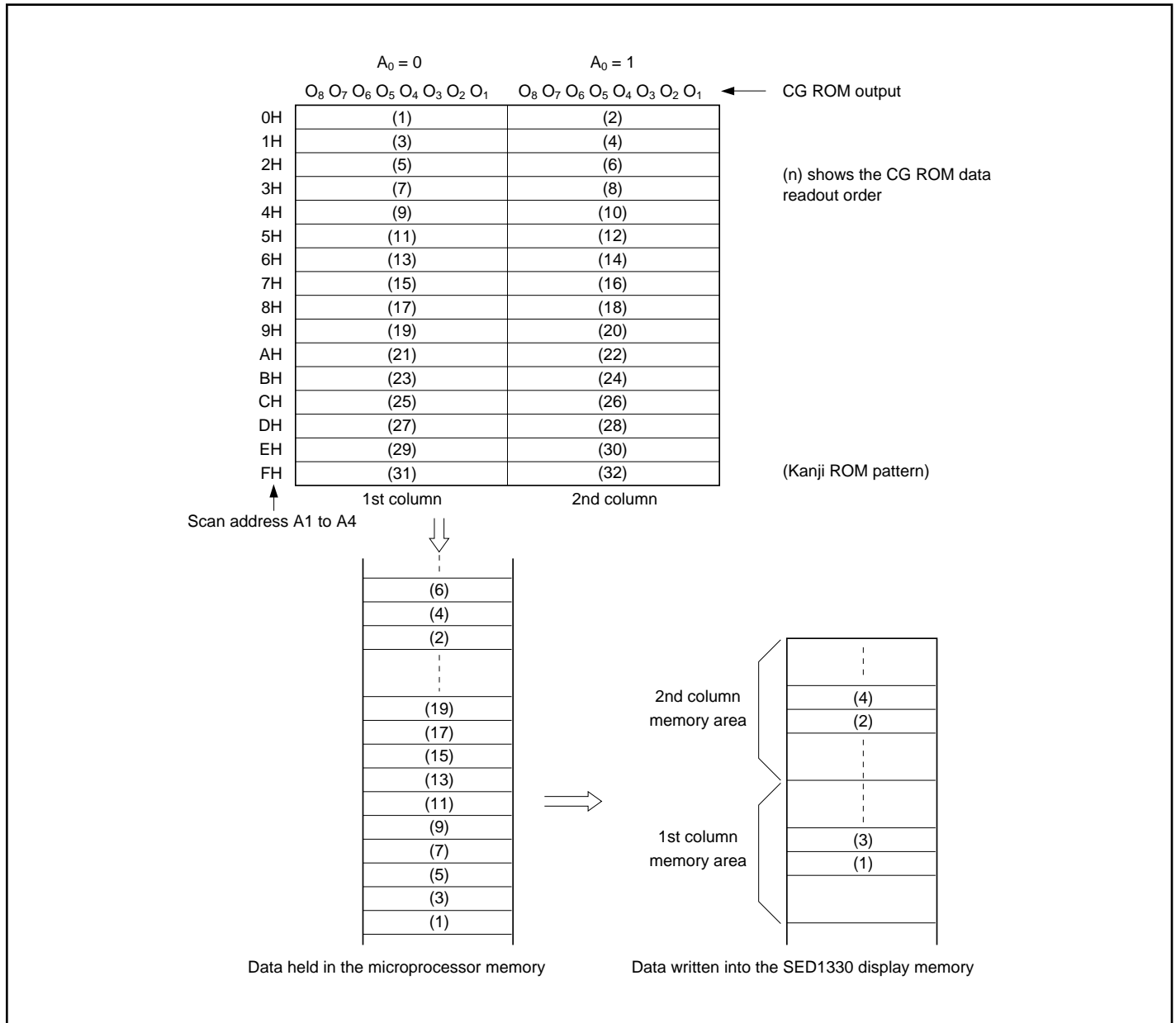

Figure 91. Graphics address indexing

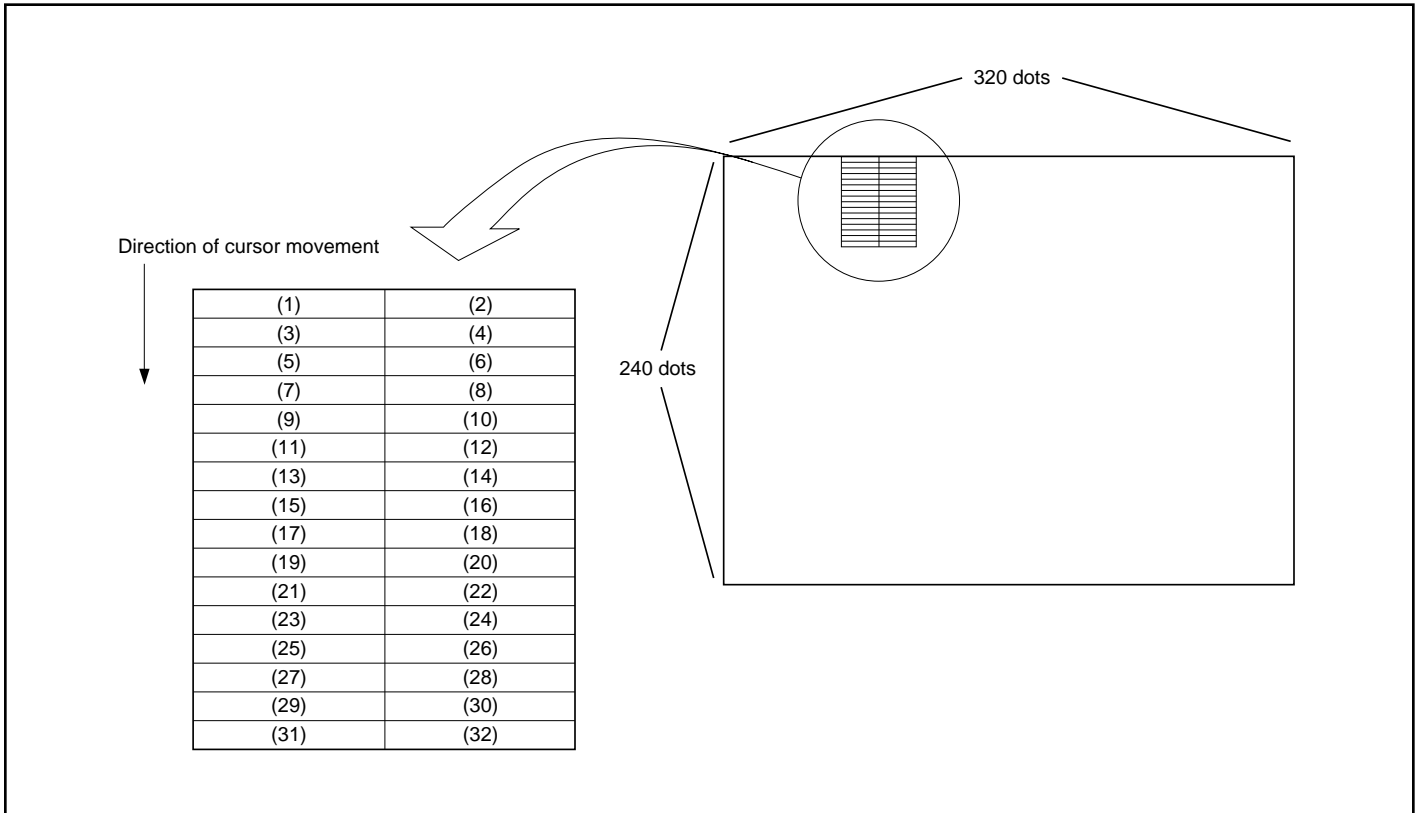

Figure 92. Graphics bit map

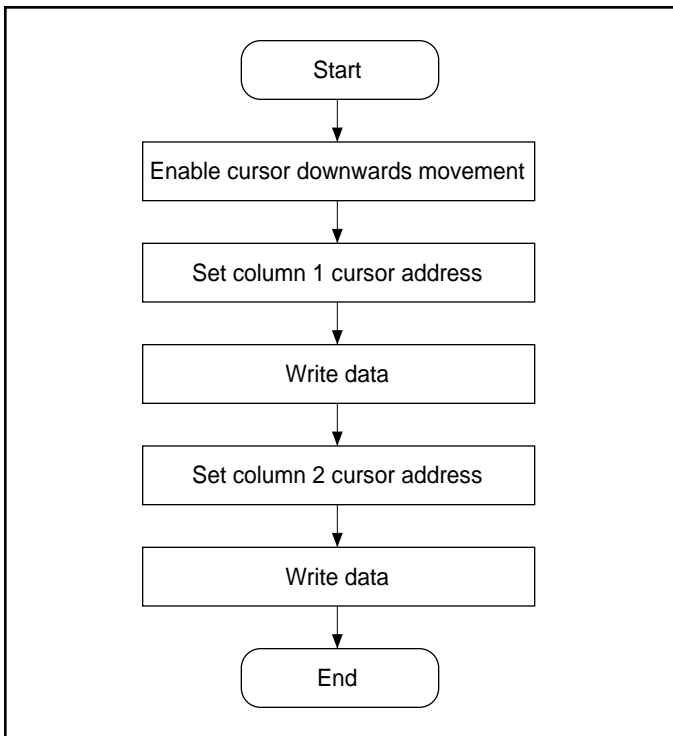

Figure 93. 16 × 16-dot display flowchart

Using an external character generator ROM, and 8 × 16-pixel font can be used, allowing a 16 × 16-pixel character to be displayed in two segments. The external CG ROM EPROM data format is described in Section 5.1. This will allow the display of up to 128, 16 × 16-pixel characters. If CG RAM is also used, 96 fixed characters and 32 bank-switchable characters can also be supported.

***10.0***  
***Internal Character***  
***Generator Font***

**THIS PAGE INTENTIONALLY BLANK**

10.0 Internal Character Generator Font

		Character code bits 0 to 3															
		0	1	2	3	4	5	6	7	8	9	A	B	C	D	E	F
Character code bits 4 to 7	2		!	"	#	\$	%	&	'	(	)	*	+	,	-	.	/
	3	0	1	2	3	4	5	6	7	8	9	A	B	C	D	E	F
	4	a	b	c	d	e	f	g	h	i	j	k	l	m	n	o	
	5	p	q	r	s	t	u	v	w	x	y	z	[	]	^	_	
	6	`	ab	cd	de	ef	gh	hi	jk	lm	no						
	7	{	}	~	st	uv	wx	yz	[	]	^	~					
	A		`	`	`	`	`	`	`	`	`	`	`	`	`	`	`
	B	`	`	`	`	`	`	`	`	`	`	`	`	`	`	`	`
	C	`	`	`	`	`	`	`	`	`	`	`	`	`	`	`	`
	D	`	`	`	`	`	`	`	`	`	`	`	`	`	`	`	`
1																	

Figure 94. On-chip character set

**Note:** The shaded positions indicate characters that have the whole 6 × 8 bitmap blackened.

**THIS PAGE INTENTIONALLY BLANK**



# *11.0*

## *Glossary of Terms*

**THIS PAGE INTENTIONALLY BLANK**

**11.0 Glossary of Terms**

A	Address
AP	Address pitch parameter
C	Character display mode
CD	Cursor direction of movement parameter
CG	Character generator
CGRAM ADR	Character generator memory address
CM	Cursor display shape parameter
C/R	Characters per row parameter
CRX	Horizontal cursor size parameter
CRY	Vertical cursor size parameter
CSR DIR	Cursor direction of movement instruction
CSR FORM	Cursor size, position and type instruction
CSRR	Read cursor address register instruction
CSRW	Write cursor address register instruction
DM	Display mode parameter
FC	Flashing cursor parameter
f <sub>FR</sub>	Frame frequency
f <sub>OSC</sub>	Oscillator frequency
FP	Screen flashing parameter
FX	Horizontal character size parameter
FY	Vertical character size parameter
G	Graphics display mode
GLC	Graphic line control unit
HDOT SCR	Horizontal scrolling by pixels instruction
IV	Screen origin compensation for inverse display
L/F	Lines per frame instruction

MREAD	Display memory read instruction
MWRITE	Display memory write instruction
MX	Screen composition mode
OV	Graphics layer select parameter
OVLAY	Screen layer mode instruction
P	Parameter
R	Row
RAM	Random access memory
ROM	Read only memory
SAD	Display scrolling start address parameter
SL	Display scrolling length parameter
TC/R	Length, including horizontal blanking, of one screen line
VRAM	Display memory
WF	Display drive waveform parameter
W/S	Windows per screen parameter

S-MOS assumes no responsibility or liability for (1) any errors or inaccuracies contained in the information herein and (2) the use of the information or a portion thereof in any application, including any claim for (a) copyright or patent infringement or (b) direct, indirect, special or consequential damages. There are no warranties extended or granted by this document. The information herein is subject to change without notice from S-MOS.

September 1995 © Copyright 1995 S-MOS Systems, Inc. Printed in U.S.A. 268-0.4