

PRODUCT DESCRIPTION

The OEM 1B uses the latest miniaturisation techniques to produce a very compact 3 ½ digit LCD voltmeter. It is designed to be a drop-in component in most medium and high volume applications, ranging from personal instrumentation and integral sensor indicators to measurement probes. The meter features 8mm digit height, 3 decimal points, auto-polarity, auto-zero, 200mV full scale reading and a very low current consumption. Connection to the module is via two dual in line rows of pins.

FEATURES

- 8mm (0.31") Digit Height
- 200mV d.c. Full Scale Reading
- 150µA @ 7.5 to 14V Operation
- Auto-zero and Auto-polarity
- Selectable Decimal Points
- Very Compact Design



TYPICAL APPLICATIONS

- Personal Gas Monitoring
- Medical Instruments
- Measurement Probes
- Hand held instruments

ORDERING INFORMATION

Standard Meter	Stock Number OEM 1B
----------------	-------------------------------

ELECTRICAL SPECIFICATIONS

Specification	Min.	Typ.	Max.	Unit
Accuracy (overall error) *		0.1		% (±1 count)
Linearity			±1	count
Sample rate		2.5		samples/sec
Operating temperature range	0		50	°C
Temperature stability		100		ppm/°C
Supply voltage (V+ to V-)	7.5	9	14**	V d.c.
Supply current		150		µA
Input leakage current (Vin = 0V)		1	10	pA

* To ensure maximum accuracy, re-calibrate periodically.

** Operation of the meter beyond the maximum supply voltage rating may cause permanent damage to the meter.

Unless otherwise noted, specifications apply at $T_A=25^{\circ}\text{C}$, $V_{\text{supply}}=5\text{Vd.c.}$ ($f_{\text{clock}}=48\text{kHz}$) and are tested with the module configured for floating input mode.

SAFETY

To comply with the Low Voltage Directive (LVD 93/68/EEC), input voltages to the module's pins must not exceed 60Vdc. The user must ensure that the incorporation of the panel meter into the user's equipment conforms to the relevant sections of BS EN 61010 (Safety Requirements for Electrical Equipment for Measuring, Control and Laboratory Use).

LASCAR ELECTRONICS LTD.
MODULE HOUSE
WHITEPARISH
WILTSHIRE SP5 2SJ
UK
TEL: +44 (1794) 884567
FAX: +44 (1794) 884616
E-mail: sales@lascar.co.uk

LASCAR ELECTRONICS INC.
3750 West 26th Street
Erie
PA 16506
USA
TEL: +1 (814) 835 0621
FAX: +1 (814) 838 8141
E-mail: us-sales@lascarelectronics.com

LASCAR ELECTRONICS (HK) LIMITED
FLAT C, 5/F., LUCKY FTY. BLDG.
63-65 HUNG TO ROAD
KWUN TONG KOWLOON
HONG KONG
TEL: +852 2797 3219
FAX: +852 2343 6187
E-mail: b4lascar@samsongroup.com.hk

DIMENSIONS

All dimensions in mm (inches)

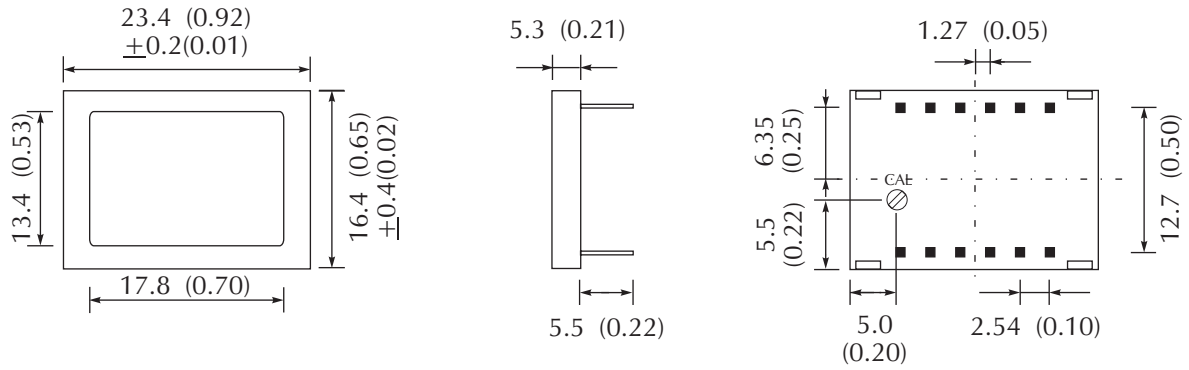

FUNCTIONAL BLOCK DIAGRAM

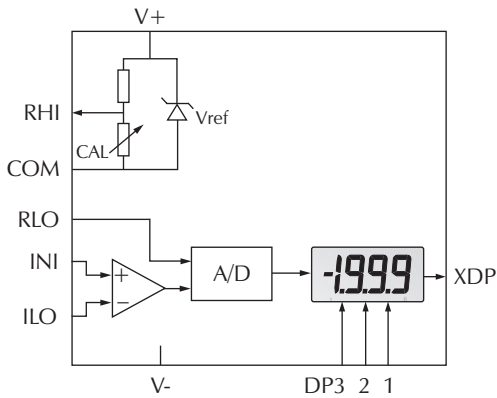

PIN CONFIGURATION (rear view)

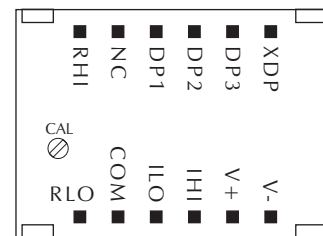

CIRCUIT DIAGRAM

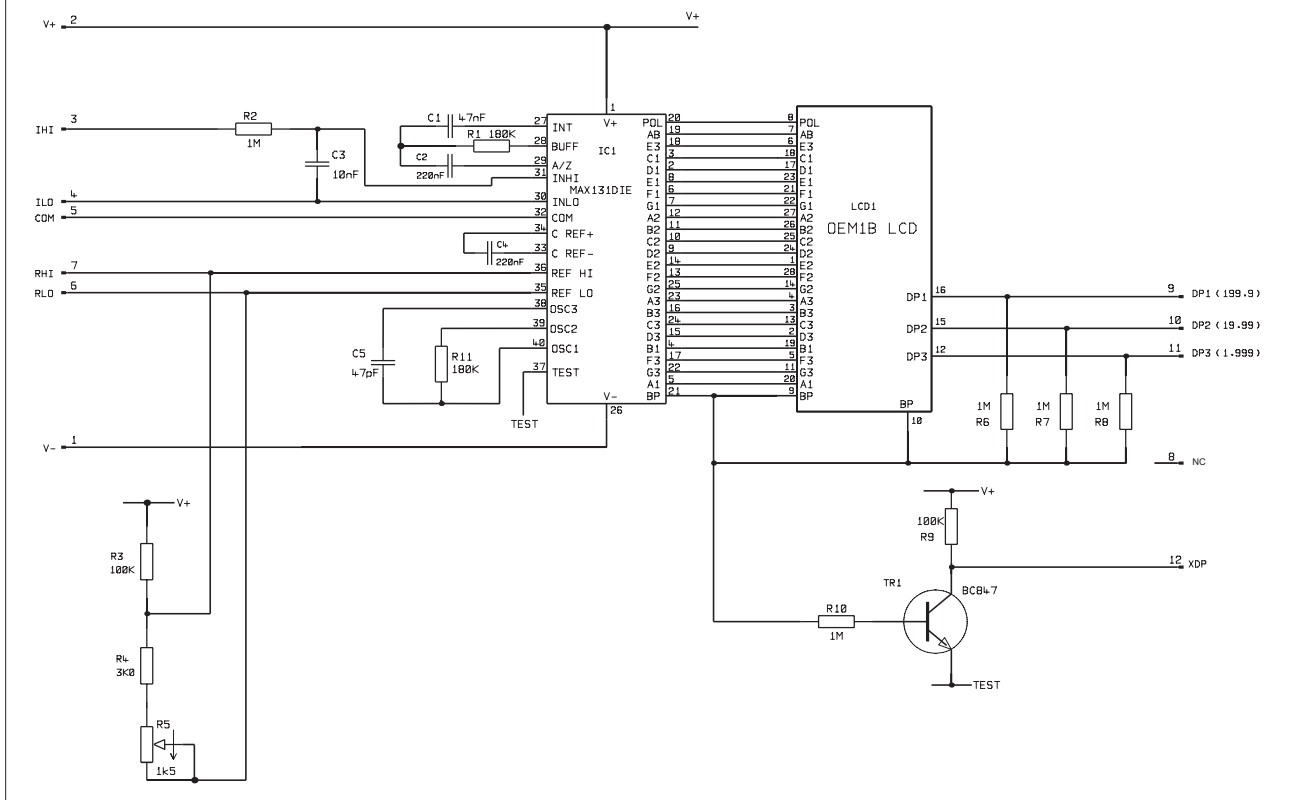

PIN FUNCTIONS

1. V- Negative power supply to the meter.
2. V+ Positive power supply to the meter.
3. IHI Positive measuring input.
IHI must be no closer than 1.6V to either the positive or negative supply, when using the internal 100mV reference.
4. ILO Negative measuring input.
ILO must be no closer than 1.6V to either the positive or negative supply, when using the internal 100mV reference.
5. COM Ground for the analogue section of the A/D converter. It is actively held at 3.05V (nom.) below V+ and must not be allowed to sink excessive current (> 100mA) by, for instance, connecting to a higher voltage.
6. RLO Negative input for the reference voltage.
7. RHI Positive input for the reference voltage.
8. NC Do not connect.
9. DP1 Connect to XDP to display DP1 (199.9).
10. DP2 Connect to XDP to display DP2 (19.99).
11. DP3 Connect to XDP to display DP3 (1.999).
12. XDP Connect to DP1, DP2 or DP3 to display required decimal points.

SCALING

Two resistors Ra and Rb may be used to alter the full scale reading (FSR) of the meter - see table. The meter will have to be recalibrated by adjusting the calibration potentiometer on the rear of the module.

	FSR	Ra	Rb
Voltage Vin	2V	910k	100k
	20V	1M	10k
	200V	1M	1k
	2000V*	1M	100R
Current Iin	200µA	0R	1k
	2mA	0R	100R
	20mA	0R	10R
	200mA	0R	1R

*Ensure that Ra is rated for high voltage use.

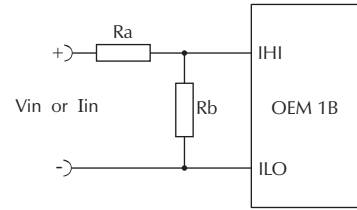

APPLICATIONS

Do not connect more than one meter to the same power supply if the meters cannot use the same signal ground. Taking any input beyond the power supply rails will damage the meter.

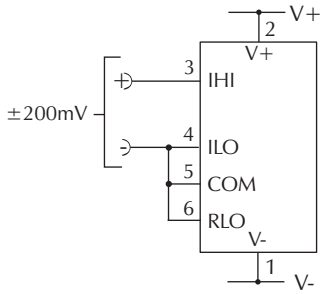

Measuring a floating voltage source of 200mV full scale.

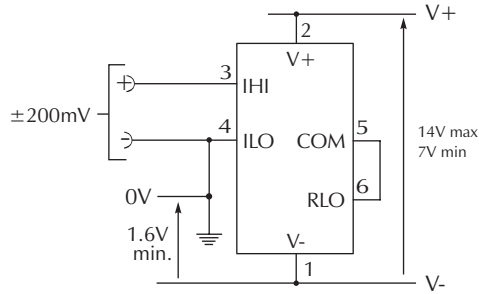

Split supply operation.

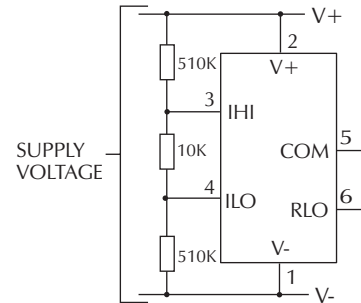

Measuring a supply voltage. (min. 7.5V, max. 14V).

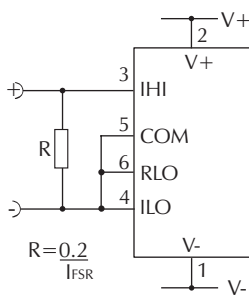

Measuring current. Supply MUST be isolated.

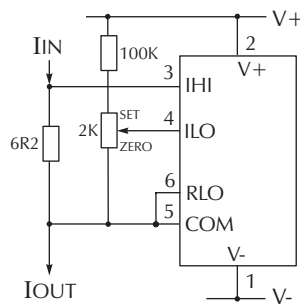

Measuring 4-20mA to read 0-999. Supply MUST be isolated.