

# LCD MODULE 4x20 - 3.73mm

Issue 10.2011

## INCL. CONTROLLER KS0073

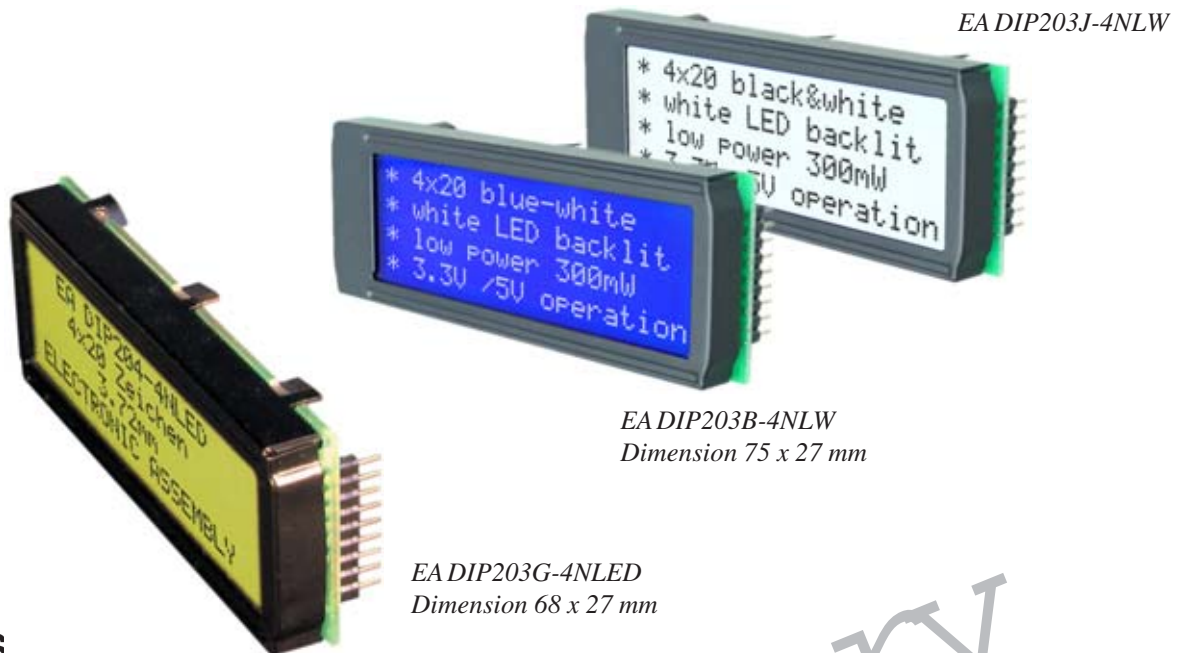

### FEATURES

- \* HIGH CONTRAST LCD SUPERTWIST DISPLAY
- \* CONTROLLER KS0073 (NEAR 100% COMPATIBLE WITH HD44780)
- \* INTERFACE FOR 4- AND 8-BIT DATA BUS
- \* SERIAL SPI INTERFACE (SID, SOD, SCLK)
- \* POWER SUPPLY +3.3V/1.5mA
- \* LED BACKLIGHT Y/G max. 150mA@+25°C
- \* LED BACKLIGHT BLUE-WHITE AND BLACK-WHITE max. 45mA@+25°C
- \* OPERATING TEMPERATURE RANGE -20..+70°C
- \* BUILT-IN TEMPERATURE COMPENSATION
- \* SOME MORE MODULES WITH SAME MECHANIC AND SAME PINOUT:
  - DOTMATRIX 1x8, 2x16
  - GRAPHIC 122x32
- \* NO SCREWS REQUIRED: SOLDER ON IN PCB ONLY
- \* DETACHABLE VIA 9-PIN SOCKET EA B200-9 (2 PCS. REQUIRED)

### ORDERING INFORMATION

LCD MODULE 4x20 - 3.73mm WITH LED BACKLIGHT Y/G  
BLUE-WHITE  
BLACK-WHITE  
9-PIN SOCKET, HEIGHT 4.3mm (1 PC.)

EA DIP203G-4NLED  
EA DIP203B-4NLW  
EA DIP203J-4NLW  
EA B200-9

**ELECTRONIC  
ASSEMBLY**

making things easy

## PINOUT

Pin	Symbo	Level	Function	Pin	Symbo	Level	Function
1	VSS	L	Power Supply 0V (GND)	10	D3	H / L	Display Data
2	VDD	H	Power Supply +5V	11	D4 (D0)	H / L	Display Data
3	VEE	-	Contrast adjustment, input	12	D5 (D1)	H / L	Display Data
4	RS (CS)	H / L	H=Data, L=Command	13	D6 (D2)	H / L	Display Data
5	R/W (SID)	H / L	H=Read, L=Write	14	D7 (D3)	H / L	Display Data, MSB
6	E (SCLK)	H	Enable (falling edge)	15	-	-	NC (see EA DIP122-5N)
7	D0 (SOD)	H / L	Display Data, LSB	16	RES	L	Reset (internal Pullup 10k)
8	D1	H / L	Display Data	17	A	-	LED B/L+ Resistor required
9	D2	H / L	Display Data	18	C	-	LED B/L-

## BACKLIGHT

Using the LED backlight requires an current source or external current-limiting resistor. Forward voltage for yellow/green backlight is 3.9~4.2V and for white LED backlight is 3.0~3.6V. Please take care of derating for  $T_a > +25^\circ\text{C}$ .

**Note:** Do never connect backlight direct to 5V; this may destroy backlight immediately !

## TABLE OF COMMAND (SSD1803, IE=HIGH)

Instruction	C ode										Description	Execute Time (270kHz)	
	RE Bit	RS	R/W	DB 7	DB 6	DB 5	DB 4	DB 3	DB 2	DB 1			DB 0
Clear Display	*	0	0	0	0	0	0	0	0	0	1	Clears all display and returns the cursor to the home position (Address 0).	1.53ms
Cursor At Home	0	0	0	0	0	0	0	0	0	1	*	Returns the Cursor to the home position (Address 0). Also returns the display being shifted to the original position. DD RAM contents remain unchanged.	1.53ms
Power Down Mode	1	0	0	0	0	0	0	0	0	1	PD	Set Power down mode bit. PD=0: powerdown mode disable PD=1: powerdown mode enable	39μs
Entry Mode Set	0	0	0	0	0	0	0	0	1	I/D	S	Cursor moving direction (I/D=0: dec; I/D=1: inc) shift enable bit (S=0: disable; S=1: enable shift)	39μs
	1	0	0	0	0	0	0	1	1	BID		Segment bidirectional function (BID=0: Seg1->Seg60; BID=1: Seg60->Seg1)	39μs
Display On/Off Control	0	0	0	0	0	0	1	D	C	B		D=0: display off; D=1: display on C=0: cursor off; C=1: cursor on B=0: blink off; B=1: blink on	39μs
extended Function Set	1	0	0	0	0	0	1	FW	BW	NW		FW=0: 5-dot font width; FW=1: 6-dot font width BW=0: normal cursor; BW=1: inverting cursor NW=0: 1- or 2-line (see N); NW=1: 4-line display	39μs
Cursor / Display Shift	0	0	0	0	0	1	S/C	R/L	*	*		Moves the Cursor or shifts the display S/C=0: cursor Shift; S/C=1: display shift R/L=0: shift to left; R/L=1: shift to right	39μs
Scroll Enable	1	0	0	0	0	1	H4	H3	H2	H1		Determine the line for horizontal scroll	39μs
Function Set	0	0	0	0	0	1	DL	N	RE	DH	RE	sets interface data length (DL=0:4-bit; DL=1:8-bit) number of display lines (N=0: 1-line; N=1: 2-line) extension register (RE= 0/1) scroll/shift (DH=0: dot scroll; DH=1: display shift) reverse bit (REV=0:normal; REV=1:inverse display)	39μs
	1	0	0	0	0	1	DL	N	RE	BE	LP	CG-/SEG-RAM blink (BE=0: disable; BE=1: enable) LP=0: normal mode; LP=1: low power mode	39μs
CG RAM Address Set	0	0	0	0	1						AC	Sets the CG RAM address. CG RAM data is sent and received after this setting.	39μs
SEG RAM Address Set	1	0	0	0	1	*	*				AC	Sets the SEG RAM address. SEG RAM data is sent and received after this setting.	39μs
DD RAM Address Set	0	0	0	1							AC	Sets the DD RAM address. DD RAM data is sent and received after this setting.	39μs
Set Scroll Quantity	1	0	0	1	*						SQ	Sets the quantity of horizontal dot scroll (DH=0)	39μs
Busy Flag / Address Read	*	0	1	BF							AC	Reads Busy flag (BF) indicating internal operation is being performed and reads address counter contents.	-
Write Data	*	1	0								Write Data	Writes data into internal RAM (DD RAM / CG RAM / SEGRAM)	43μs
Read Data	*	1	1								Read Data	Reads data from internal RAM (DD RAM / CG RAM / SEGRAM)	43μs



## DRIVING WITH 5V-SYSTEMS

The supply voltage of the display is necessarily 3.3V. If a 5V-system is used, the level have to be adapted. For example you can use a bidirectional levelshifter (e.g. PS 74LVC4245A), like shown in the opposite figure.

## COMPATIBILITY WITH EA DIP204-4

The displays of EA DIP203 and EA DIP204 series are electrically and mechanically identical to each other running with 3.3V supply mode. Merely a 5V supply is not acceptable with the new EA DIP203 series.

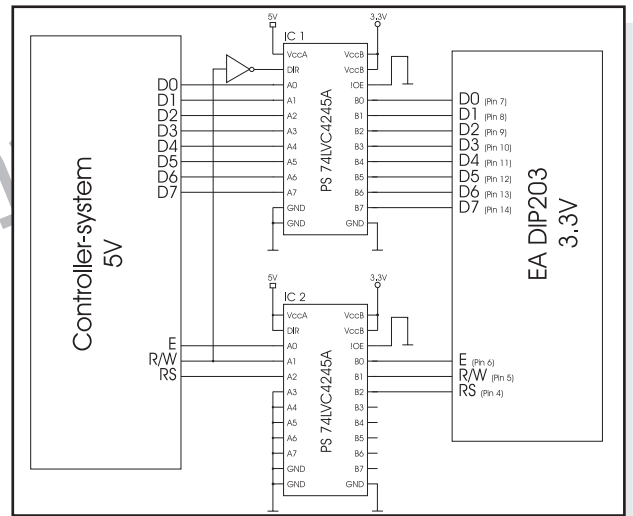

Note:  
LC-Displays are generally not suited to wave or reflow soldering. Temperature of over 90°C can cause lasting damage.

## EA DIP203G-4NLED

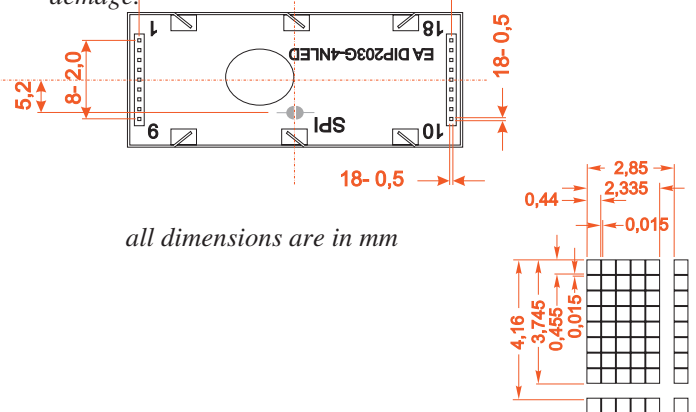
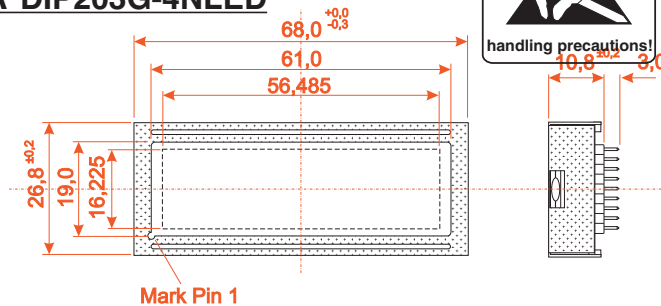

## EA DIP203B-4NLW und EA DIP203J-4NLW

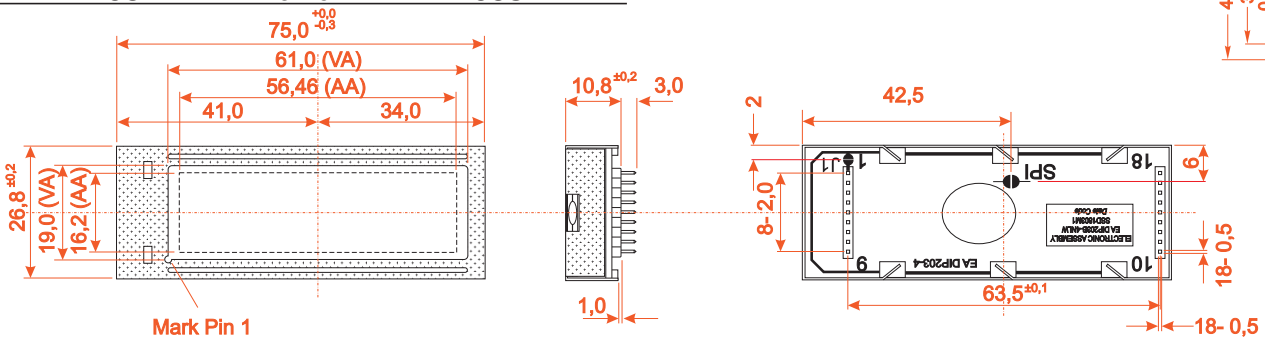

## SERIAL MODE

Factory set for interface is parallel with 4 bit or 8 bit data bus. Alternative module can be programmed with serial data stream. For that solder link 4/8 has to be opened and closed to SPI side. Specification for serial operation mode is written down in user manual for SSD1803:

[http://www.lcd-module.de/fileadmin/eng/pdf/zubehoer/SSD1803\\_0.20.pdf](http://www.lcd-module.de/fileadmin/eng/pdf/zubehoer/SSD1803_0.20.pdf)

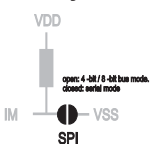

**ELECTRONIC ASSEMBLY**

making things easy